

## Article

# The Use of Chemical Cues by *Sargassum* Shrimps *Latreutes fucorum* and *Leander tenuicornis* in Establishing and Maintaining a Symbiosis with the Host *Sargassum* Algae

Jaime L. Frahm and William Randy Brooks \*

Department of Biological Sciences, Florida Atlantic University, Boca Raton, FL 33431, USA;  
jaimelfrahm@gmail.com

\* Correspondence: wbrooks@fau.edu; Tel.: +1-561-297-3888

**Abstract:** A mutualistic symbiosis exists between the alga *Sargassum* spp. and two shrimp species, *Latreutes fucorum* and *Leander tenuicornis*. However, little is known about how these shrimp locate and establish their host alga. Both visual and chemical cues are potentially available. A previous study has looked at both cue variables with results that are mixed. Specifically, these same shrimp species used chemical cues only when visible cues were available simultaneously. Visual cues would be presumably restricted at night, but chemical cues are potentially available continuously. This current research elaborates on the previous study to fully understand *Sargassum* shrimp chemoreception. Increases in sample sizes and both a 4-chambered and Y-maze apparatus were used to test whether the shrimp could detect *Sargassum* cues, dimethylsulfoniopropionate (DMSP) (a chemical excreted by some marine algae), and conspecific cues. Neither shrimp species showed a strong directional response to any of the chemical cues, but the *Sargassum* and DMSP cues did cause more shrimp to exhibit searching behavior. Additionally, several differences in responses between male and female shrimp were found for each cue. A lowered dilution of DMSP was also tested to determine sensitivity of *L. fucorum* shrimp to the chemical cue; although searching behavior was triggered, conclusions about quantifying the sensitivity could not be made. Overall, these results show the shrimp can detect chemical cues—in the absence of visual cues—that could affect initiating and maintaining this shrimp/algal symbiosis.



**Citation:** Frahm, J.L.; Brooks, W.R. The Use of Chemical Cues by *Sargassum* Shrimps *Latreutes fucorum* and *Leander tenuicornis* in Establishing and Maintaining a Symbiosis with the Host *Sargassum* Algae. *Diversity* **2021**, *13*, 305. <https://doi.org/10.3390/d13070305>

Academic Editors: Patricia Briones-Fourzán and Michel E. Hendrickx

Received: 15 June 2021  
Accepted: 2 July 2021  
Published: 6 July 2021

**Publisher's Note:** MDPI stays neutral with regard to jurisdictional claims in published maps and institutional affiliations.



**Copyright:** © 2021 by the authors. Licensee MDPI, Basel, Switzerland. This article is an open access article distributed under the terms and conditions of the Creative Commons Attribution (CC BY) license (<https://creativecommons.org/licenses/by/4.0/>).

**Keywords:** symbiosis; *Sargassum* shrimps; chemical cues

## 1. Introduction

Pelagic, floating mats of primarily *Sargassum fluitans* and *Sargassum natans* algae are found in both tropical and temperate waters of the Atlantic Ocean [1,2]. These species are characterized with highly branched thalli and small air bladders (pneumatocysts) that keep the algae afloat [1]. *S. natans* differs from *S. fluitans* with thinner blades and a spine located on the pneumatocysts [3] (see Figure A1 in Appendix A).

These floating mats range greatly in size from small patches less than 0.5 m in horizontal diameter up to huge mats 50 m in diameter [1,4]. Several factors contribute to this broad range in sizes. For example, sustained calm conditions can allow *Sargassum* mats to form large aggregations, but harsher weather conditions such as high winds can break up large mats of *Sargassum* or create narrower windrows [4]. As the algae approach the shoreline, wave action can break up mats into significantly smaller sizes. Boats and other watercrafts running through the mats could also cause further disruption of *Sargassum* mat structure and size. Wind can also push *Sargassum* on to shores in the Atlantic and Caribbean, sometimes in huge mass events [5]. However, *Sargassum* can also be found in the Sargasso Sea in high quantities [1,6].

Some associated species, such as *Sargassum* shrimp, form a symbiosis with these algae and are rarely found elsewhere [1]. With so many species reliant either part of or their

entire lives on the *Sargassum* habitat, it has been designated as an Essential Fish Habitat [7]. While many studies have focused on species richness and diversity within the *Sargassum* habitat, very little is known about details of interactions among the symbionts and host algae [3]. *Sargassum* shrimp are the most abundant macro invertebrates in *Sargassum* mats.

There are two species of *Sargassum* shrimp, *Latreutes fucorum* and *Leander tenuicornis*, both of which exhibit camouflage and coloration closely resembling the brown and yellow colors of *Sargassum* algae, making it challenging for the observer to locate them within the habitat [1]. These shrimp occupy positions in the algal mats based on the frond characteristics and depth of the fronds in the water column. For example, *L. tenuicornis* shows a preference for deeper floating *Sargassum* patches (10–12 cm below the surface) than shallow patches. Additionally, *L. tenuicornis* positions itself in a parallel alignment with the fronds, thus allowing the shrimp to blend with the fronds and exhibit algal morphology mimicry [8]. Such behaviors by *L. tenuicornis* and its innate camouflage maximize protection from predators such as jacks, sargassum fish (*Histrion histrio*) and the gray triggerfish (*Balistes capriscaus*), the last of which is one of the most abundant fish in *Sargassum* and feeds almost exclusively on *Sargassum* shrimp [1,7]. Clearly, *Sargassum* shrimp are vital components of the *Sargassum* community and food chain. Therefore, this study focused on these two species of shrimp.

A mutualistic symbiosis is formed when two organisms live together and provide reciprocal benefits. In the symbiosis between *Sargassum* and these shrimp, the alga is a host that provides shelter and protection to the shrimp [9]. In return, shrimp and other animals provide nutrients to the algae [10]. Mutual benefits to symbionts can help explain why an association occurs, but another critical aspect is understanding how the symbiosis is initiated and maintained. Typically, the smaller, more mobile symbiont is the one to seek out and form the symbiosis with the larger symbiont or host [3].

This leads to the question about how shrimp symbionts locate the *Sargassum* patches, which are temporally and spatially highly variable in abundance [11–13]. Presumably, the shrimp must initially locate such patches of *Sargassum* algae. DNA analysis of *L. fucorum* shows the shrimp are highly dispersive during the planktonic larval stage [2]. Additionally, juveniles and those individuals separated from mats by biotic perturbations (e.g., disruptive feeding actions by large, pelagic species such as dolphinfish, *Coryphaena hippurus* [1,13–15]), and abiotic perturbations [(e.g., wind and waves that break up patches, or when mats are driven onto beaches, cf. [5]); and anthropogenic events (e.g., algal mat disruption by boats)] must locate and re-establish association with new, displaced or larger algal mats.

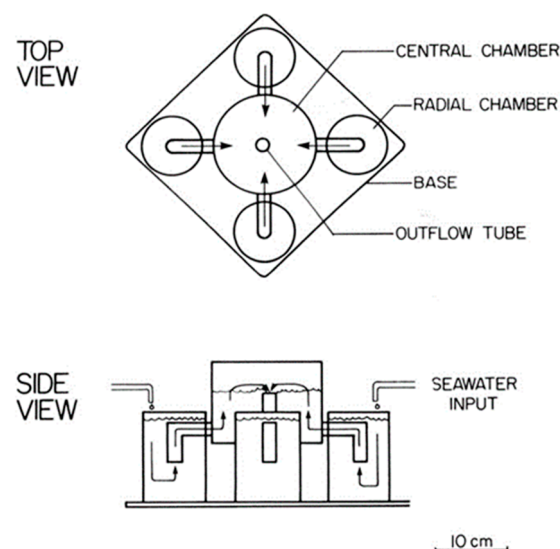
Visual cues are mostly available during the daytime and would be potentially available at limited distances only, based on the visual abilities of the shrimp. However, chemical cues would likely be available most of the time, and distance would be potentially less of a problem than using visual cues exclusively.

There is an abundance of chemical cues in the marine habitat, as every organism releases some type of chemical signal into the environment via metabolic activity [16]. Once a chemical is released into the water, the molecules disperse by undergoing diffusion or bulk flow, which is the movement of molecules from high to low pressure [16]. There are many marine organisms that can detect chemicals via chemoreceptors [17]. Receptors must be both highly specific and diverse for organisms to identify an array of specific chemicals within the environment [16]. These chemicals are used to locate food, avoid predators, find a mate, find a suitable habitat, homing, recognize conspecifics, and mediate social behavior (such as forming a hierarchy) [17]. Specifically, chemoreceptive organs on decapods contain sensilla, which are either hair like or rod shaped [17]. The sensilla are usually located on the antennules but can also be found on parts of the mouth and legs [17].

The American lobster (*Homarus americanus*) can detect specific chemical cues to recognize individual lobsters and form dominance hierarchies [16]. Another example of a chemoreceptive crustacean is the porcellanid crab (*Porcellana sayana*), which uses chemical cues to locate sea anemones associated with hermit crabs [18]. Yet another crustacean, the rock shrimp (*Rhynchocinetes typus*) uses chemoreception to find and select mates [19].

Dimethylsulfoniopropionate (DMSP) is a chemical cue excreted by some marine algae, e.g., dinoflagellates [20,21] and benthic *Sargassum* species [22], that is detected by a variety of marine animals [23–25]. It can potentially attract zooplankton predators to minimize grazing on the phytoplankton [26]. Potentially high DMSP concentrations are also present in areas where primary productivity and foraging activity are high, which include windrows where *Sargassum* and other potential DMSP-producing organisms aggregate to form weedlines [27]. DeBose et al. [27] showed that some fishes (e.g., jacks, *Caranx hippos* and *C. melampyrgus*) associated with *Sargassum* mats responded significantly to cues of DMSP. DMSP concentrations of  $10^{-9}$  M in the Sargasso Sea were found, which indicate that this compound could be used as a cue for symbionts to locate *Sargassum* patches [28].

This current research paper is based on a prior study by Jobe and Brooks [3] on the importance of chemical and visual cues for *Sargassum* shrimp in locating and selecting habitat. The questions addressed by this previous study were whether chemical and visual cue responses to *Sargassum* algae occurred by *L. tenuicornis* or *L. fucorum*, and whether these shrimp have preferences for a different *Sargassum* species. In that study, two types of apparatus were used: (1) 4-chambered olfactometer (Figure 1) to test for chemical cues only, and (2) aquarium with, first, chemical cues blocked and visual cues available (by placing the algae in beakers thereby allowing only visual cues), then chemical cues and visual cues by placing algae directly in the water with the shrimp.



**Figure 1.** Four-chambered choice apparatus.

Although there were no significant differences detected in the “chemical cues only” trials, there was significance in the “visual only” and the “visual plus chemical” cue trials. Specifically, “visual cues only” trials showed several specific significant results: (1) *L. fucorum* chose live *Sargassum* over artificial *Sargassum* and *S. natans* over *S. fluitans*; (2) small-sized *L. tenuicornis* chose *S. natans* over artificial *Sargassum*, and large-sized *L. tenuicornis* chose *S. fluitans* over *S. natans* and artificial *Sargassum*. However, when both visual and chemical cues were present, there were additional significant similar and differing results: (1) neither shrimp species had a significant preference for a specific *Sargassum* species, and (2) small *L. tenuicornis* selected *S. fluitans* over artificial algae. Although chemical cues from *Sargassum* were unavailable in the “visual cues only” trials, they were still present in the latter set of trials (i.e., both visual and chemical cues were available to the shrimp). While these results do not demonstrate that *Sargassum* shrimp responded to chemical cues in the 4-chambered apparatus trials, they do not preclude the possibility that chemoreception was employed by the shrimp.

The objective of this current research was to elaborate on the previous study to fully understand *Sargassum* shrimp chemoreception. Increases in sample sizes and both a 4-

chambered and a Y-maze apparatus were used to test whether the shrimp could detect *Sargassum* cues, dimethylsulfoniopropionate (DMSP) (a chemical excreted by some marine algae), and conspecific cues.

Overall, these results showed the shrimp can detect chemical cues—in the absence of visual cues—that could affect initiating and maintaining this shrimp/algal symbiosis.

## 2. Materials and Methods

### 2.1. Collection and Maintenance of Specimens

Organisms used in this study were collected via boat off the east coast of Florida near the Boca Inlet. Using a large dip net, clumps of *Sargassum* algae were collected and put into plastic coolers. The shrimps, *Latreutes fucorum* and *Leander tenuicornis*, were separated from the algae immediately on the boat. Extra algae and any other organisms collected unintentionally were returned to the water. The algae and shrimp were then transported back to Florida Atlantic University in plastic coolers. A total of 2800 shrimp were collected for use in trials.

Organisms were placed in holding tanks with filters in the laboratory with seawater made from sea salt mix, and the salinity maintained at 32–35 ppt. (Seawater for all trials was also made using sea salt mix.) Once the temperature of the water in the coolers matched the temperature of the water in the holding tanks, the shrimp were separated by size groups (e.g., shrimp less than 5 mm, measured from rostrum to tail, were separated from larger shrimp to minimize potential aggression and predation). Shrimp were acclimated to their laboratory environment a minimum of 6 h before being used in any experimental trials. All shrimp were tested within 3 days of collection.

### 2.2. Four-Chambered Apparatus Trials

A 4-chambered apparatus (Figure 1) was set up with equal amounts of synthetic seawater running through each radial chamber by dripping via plastic tubing from four separate seawater/chemical sources elevated (gravity forces water flow) so that water flowed simultaneously via each of the four seawater inputs into their respective radial chambers and into the central chamber before draining out of the apparatus. Animals were subsequently placed in the central chamber and could enter any of the 4 radial chambers. Blinds were placed around the apparatus to minimize light cues and maximize the potential use of chemical cues.

For the control trials, all four radial chambers had plain (i.e., no chemical cues experimentally added) seawater running through them. This control allowed for examination of the shrimps' behavior in the absence of an added chemical cue. Groups of 30 shrimp were placed into the central chamber of the apparatus. Two size groups of *L. fucorum* were tested: Group 1  $\geq 10$  mm, and Group 2  $< 10$  mm. *L. tenuicornis* was not tested using the 4-chambered apparatus due to low collection numbers. After 4 h, the location of the shrimp within the apparatus was recorded. Specifically, the number of individuals in each radial chamber after 4 h was recorded and treated as a positive response. The number of individuals that remained in the central chamber was also recorded. No shrimp individuals were used more than once in any trials in this and all other experiments. Trials were replicated with new groups of 30 shrimp a minimum of 10 times. The distribution of the animals within the apparatus (i.e., how many were in any of the radial chambers versus those still in the central chamber) after 4 h was analyzed using binomial tests.

Three types of chemical cue sources were used separately in the choice experiments, *Sargassum*, dimethylsulfoniopropionate (DMSP), and conspecifics. For the *Sargassum* chemical cue treatment, 2 kg of *Sargassum* was collected and placed in 37 L of synthetic seawater for 48 h to allow any chemical compounds to be released into the water. *Sargassum* composition can vary greatly throughout the year due to many factors such as age, amount of epibiotic growth, species present, and seasonal conditions. To minimize chemical composition variability in *Sargassum* effluent between trials, 45 mL aliquots were taken from one batch and then frozen for subsequent use throughout experimentation (see [29]). Three

additional batches of *Sargassum* chemical effluent were made using *Sargassum* collected at different times of the year. This was done to minimize potential variation between chemical cues from *Sargassum* batches collected throughout three years of research. For use in trials, a 100% concentration of *Sargassum* effluent solution was used. For the DMSP chemical treatment, synthetic seawater mixture containing DMSP at a concentration of  $10^{-5}$  was used ( $10^{-9}$  M is a concentration commonly occurring in situ; [27,28]). These *Sargassum* and DMSP solutions were the strongest concentrations used in trials and were tested first to determine whether the shrimp responded.

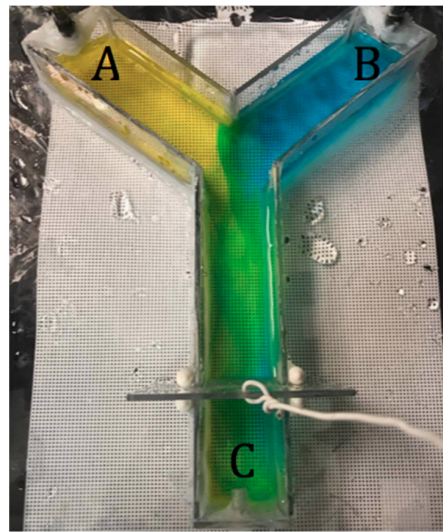
For *Sargassum* chemical cue trials, *Sargassum* effluent was added to one randomly selected radial chamber water source. Again, groups of *L. fucorum* were placed in the center and allowed to move between the radial chambers for a 4 h duration before the location of the shrimp was recorded. The same procedure occurred for the DMSP chemical cue trials. For conspecific chemical cues, 10 live *L. fucorum* shrimp were placed directly into a water source for the 4-chambered apparatus. A chi-square goodness of fit test was used to compare the number of shrimp that moved from the central chamber based on the two size groups, and *t*-tests were used to analyze the data. A one-way ANOVA was used to determine whether the number of shrimp that moved in the control data and the three treatments were significantly different.

### 2.3. Y-Maze Trials

A Y-maze apparatus (Figure 2) was set up with equal amounts of synthetic seawater running through each branch (areas A and B) and draining out of the apparatus (area C). Shrimp were tested by initially placing an individual in area C. A perforated plexiglass gate was in place to keep the shrimp in the initial area C for a 10 min acclimation period while the flow of water from both branches moved through the system. After 10 min, the perforated gate was raised using a pulley system, and the shrimp were free to explore the remaining areas of the Y-maze for an additional 20 min. To minimize observer interactions, a camera was used to monitor initial choice and subsequent movements of the shrimp. Preliminary observations showed that smaller shrimp were difficult to see in the video recordings, so only shrimp that  $\geq 10$  mm in length were used these trials. The sex of each shrimp was determined after use in trials by observing the presence (male) or absence (female) of the appendix masculina on the second pleopods [30]. Again, light levels were minimized by placing a blind around the apparatus.

For control trials, the two branches received synthetic seawater with no chemicals added. For treatment trials, the three chemical cues were tested in separate trials by randomly assigning the branches (either A or B) with the chemical cue using the same preparation and solution concentrations described for the 4-chambered apparatus trials. After the data were statistically analyzed for these concentrations, it was deemed appropriate to use a weaker DMSP solution in the *L. fucorum* trials to test the sensitivity of the shrimps' chemoreception to the cue. The additional concentration of  $10^{-9}$  M (compared to the initial concentration of  $10^{-5}$ ) was used, which is a concentration commonly occurring in situ [27,28]. Approximately 100 replications each for *L. fucorum* and 50 replications each for *L. tenuicornis* were tested for the controls and three treatments.

A binomial test was used to determine whether significantly more shrimp moved out of area C in the presence of a cue. For the shrimp that moved out of area C, the binomial test was used to determine whether significantly more shrimp initially chose the cue side. Additionally, for the shrimp that moved out of area C, a paired *t*-test repeated-measures ANOVA was used to determine whether there were any differences in time spent in the arm with the cue compared to the arm without the cue between the control and treatment trials.



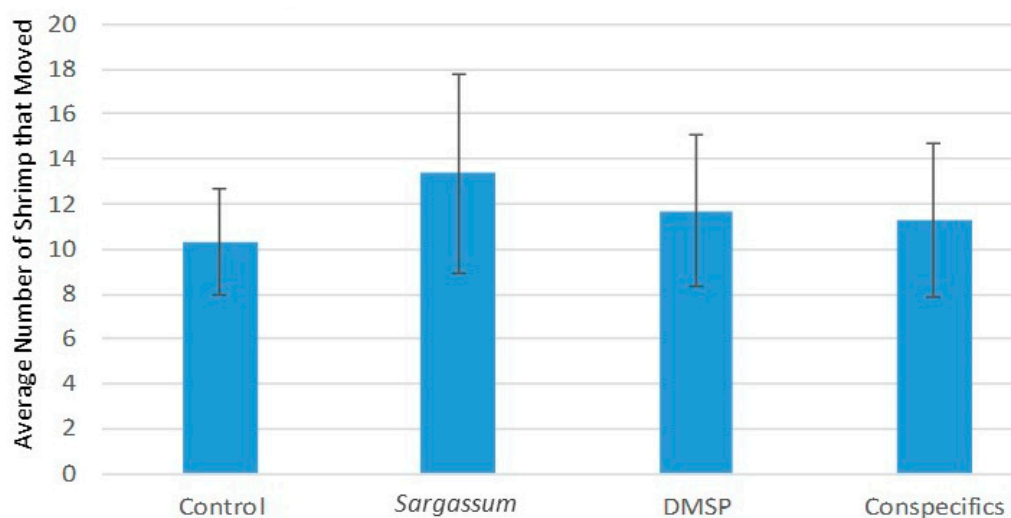
**Figure 2.** Y-maze apparatus. Blue and yellow dyes demonstrate symmetrical flow from each arm or branch (A,B) into the base arm (C) where shrimp is initially placed prior to starting a trial.

### 3. Results

#### 3.1. Four-Chambered Apparatus Trials

Controls (when no chemical cues were present in any of the four chambers) showed no significant difference in choice by *Latreutes fucorum* from the null hypothesis of 25% for each of the chambers (binomial test, all  $p > 0.05$ ), which shows the system was unbiased. *Leander tenuicornis* was not tested using the 4-chambered apparatus due to low collection numbers.

A one-way ANOVA showed the average number of *L. fucorum* that moved (regardless of their eventual chamber selection) from the center of the apparatus did not differ significantly among the control and three separate treatments ( $p = 0.14$ ) (Figure 3). However, a specific post hoc *T*-test comparing the number of shrimp moving into radial chambers in the presence of *Sargassum* chemical cues (13.36) was slightly higher than in the control trials (10.29) ( $p = 0.03$ ) (Figure 3). When comparing the total number of shrimp that moved and made a radial chamber selection, no significant differences were detected (chi-square goodness of fit,  $p > 0.05$ ).



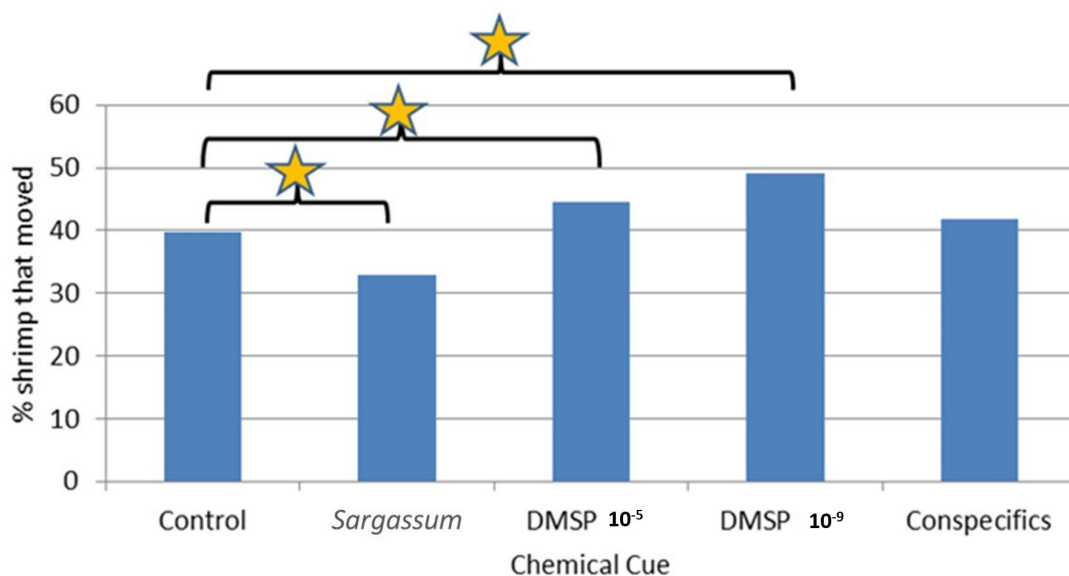
**Figure 3.** Average number of *Latreutes fucorum* shrimp that moved out of the central chamber of the 4-chambered apparatus for the control, *Sargassum*, DMSP and conspecifics trials (one-way ANOVA,  $p = 0.14$ ). Post hoc *T*-test comparing the number of shrimp moving in the chemical presence of *Sargassum* (13.36) was slightly higher than in the control trials (10.29) ( $p = 0.03$ ). Error bars indicate standard deviations.

Chi-square tests also showed no significant difference in responses to chemical cues between the two size groups of shrimp (all  $p > 0.05$ ).

### 3.2. Y-Maze Trials

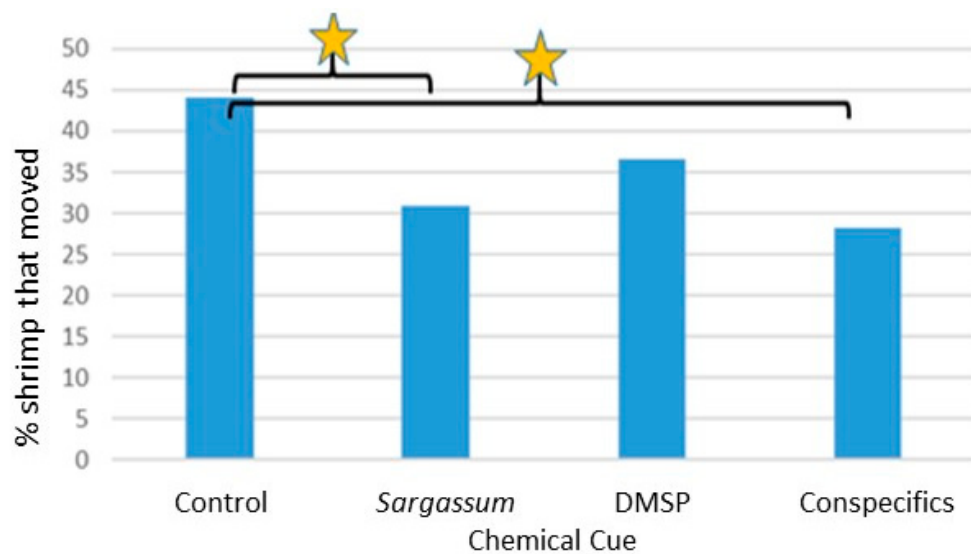
*T*-tests on the control data showed no significant difference in the amount of time spent in each arm of the apparatus for both species of shrimp; this shows the system was unbiased (*L. fucorum*  $p = 0.10$ , *L. tenuicornis*  $p = 0.25$ ). Additionally, a chi-square analysis of the control data showed no significant difference between sex and the number of shrimp that moved out of holding area C (*L. fucorum*  $p = 0.24$ , *L. tenuicornis*  $p = 0.53$ ).

For the treatment trials, binomial tests showed that significantly fewer shrimp for both species moved out of the area C (see Figure 2) in the presence of a *Sargassum* chemical cue (*L. fucorum*  $p = 0.03$ , *L. tenuicornis*  $p = 0.03$ ) (Figures 4 and 5, respectively). Additionally, significantly fewer *L. tenuicornis* moved out of area C in the presence of conspecific chemical cues ( $p = 0.01$ ) (Figure 5). Alternatively, significantly more *L. fucorum* moved in the presence of both DMSP chemical cue concentrations when compared with the control (DMSP  $10^{-5}$  M  $p = 0.05$ , DMSP  $10^{-9}$  M  $p = 0.01$ ) (Figure 4).

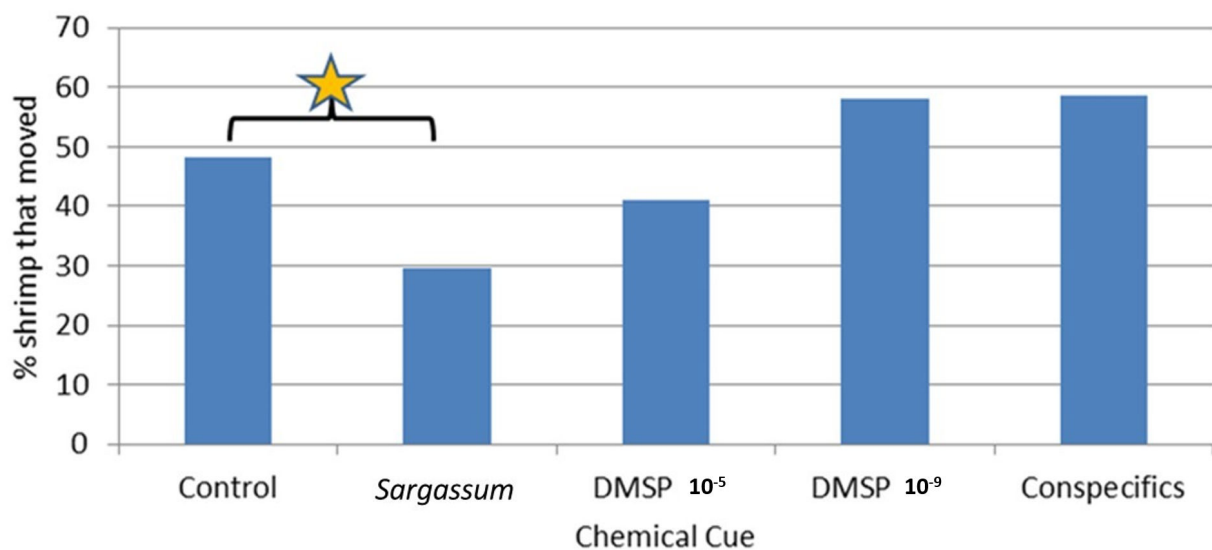


**Figure 4.** Number of *Latreutes fucorum* shrimp that moved out of area C in the Y-maze for the control, *Sargassum*, DMSP  $10^{-5}$  M, DMSP  $10^{-9}$  M, and conspecific cue trials (binomial test; *Sargassum*,  $p = 0.03$ ; DMSP  $10^{-5}$  M,  $p = 0.05$ ; DMSP  $10^{-9}$  M,  $p = 0.01$ ; and conspecifics,  $p = 0.08$ ). Star/bracket indicates significant differences between indicated paired groups.

The same binomial tests were also used to determine whether parsing the data by sex had any effect on significant findings. *L. fucorum* males moved less in *Sargassum* cue trials when compared to the control males ( $p = 0.01$ ) (Figure 6), and females moved more in both DMSP concentrations compared to the control females (DMSP  $10^{-5}$  M  $p = 0.01$ , DMSP  $10^{-9}$  M  $p = 0.02$ ) (Figure 7). *L. tenuicornis* females moved significantly less in both the *Sargassum* and the conspecifics cues (*Sargassum*  $p = 0.02$ , conspecifics  $p = 0.01$ ) (Figure 8). No significance was found for *L. tenuicornis* males (all  $p > 0.05$ ).



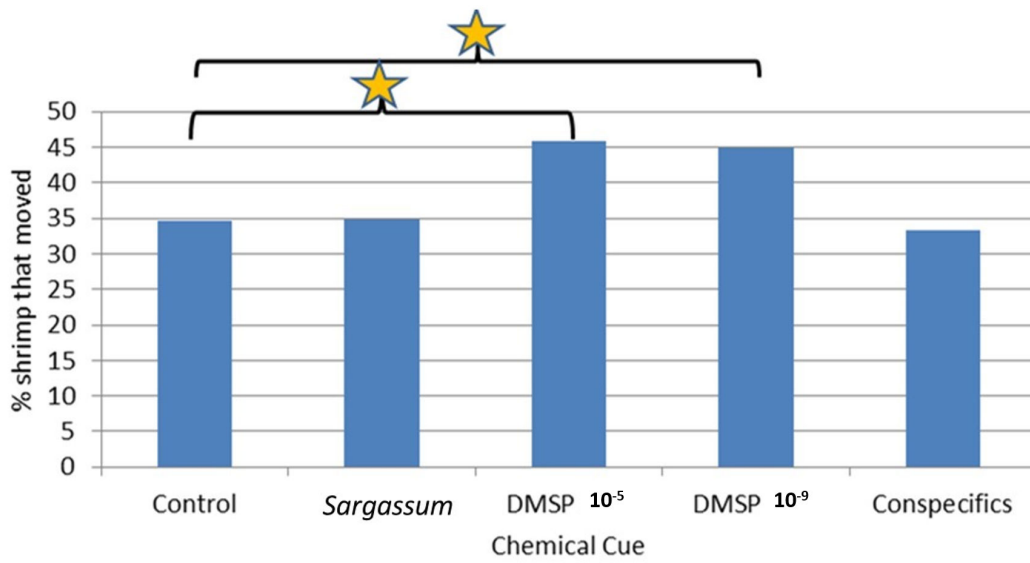
**Figure 5.** Number of *Leander tenuicornis* shrimp that moved out of area C in the Y-maze for the control, *Sargassum*, DMSP  $10^{-5}$  M, and conspecific cue trials (binomial test; *Sargassum*,  $p = 0.03$ ; DMSP,  $p = 0.08$ ; and conspecifics,  $p = 0.01$ ). Star/bracket indicates significant differences between indicated paired groups.



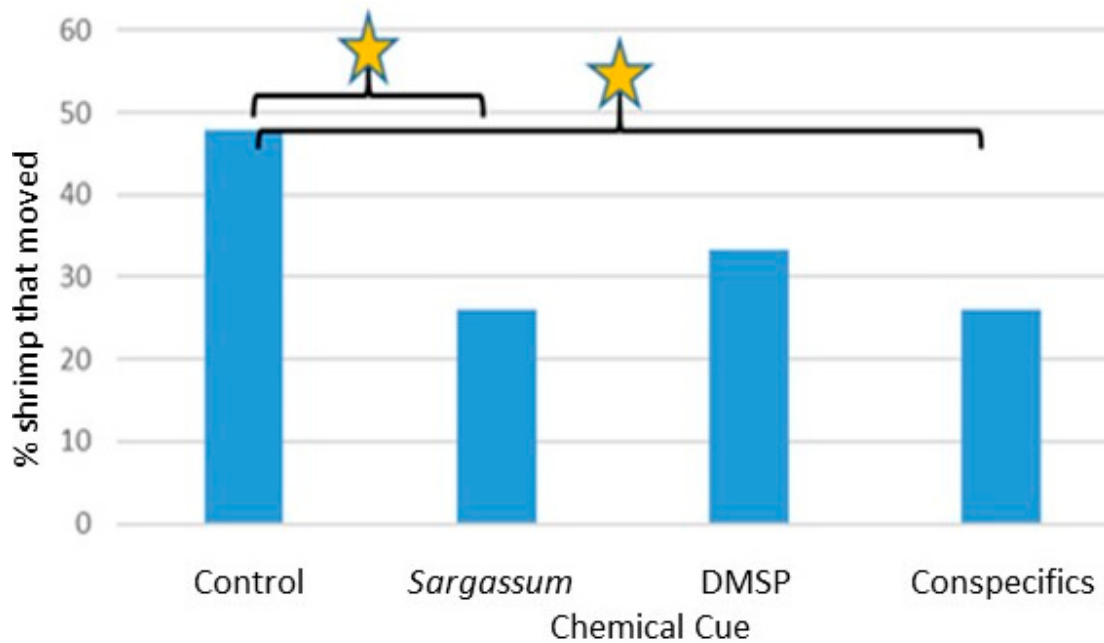
**Figure 6.** Number of *Latreutes fucorum* male shrimp that moved out of area C in the Y-maze for the control, *Sargassum*, DMSP  $10^{-5}$  M, DMSP  $10^{-9}$  M, and conspecific cue trials (binomial test; *Sargassum*  $p = 0.01$ ; DMSP  $10^{-5}$  M  $p = 0.10$ ; DMSP  $10^{-9}$  M  $p = 0.08$ ; and conspecifics,  $p = 0.08$ ). Star/bracket indicates significant differences between indicated paired groups.

For the shrimp that moved out of area C, a binomial test was used to determine whether significantly more shrimp initially chose the arm of the maze with a cue over the arm of the maze without a cue. *L. fucorum* males chose the cue side over the non-cue side in the conspecifics chemical cue trials ( $p = 0.05$ ) (Figure 9). No other significance was found for *L. fucorum* in the *Sargassum* or DMSP trials, and no significance was found for *L. tenuicornis* for any of the cues (all  $p > 0.05$ ).

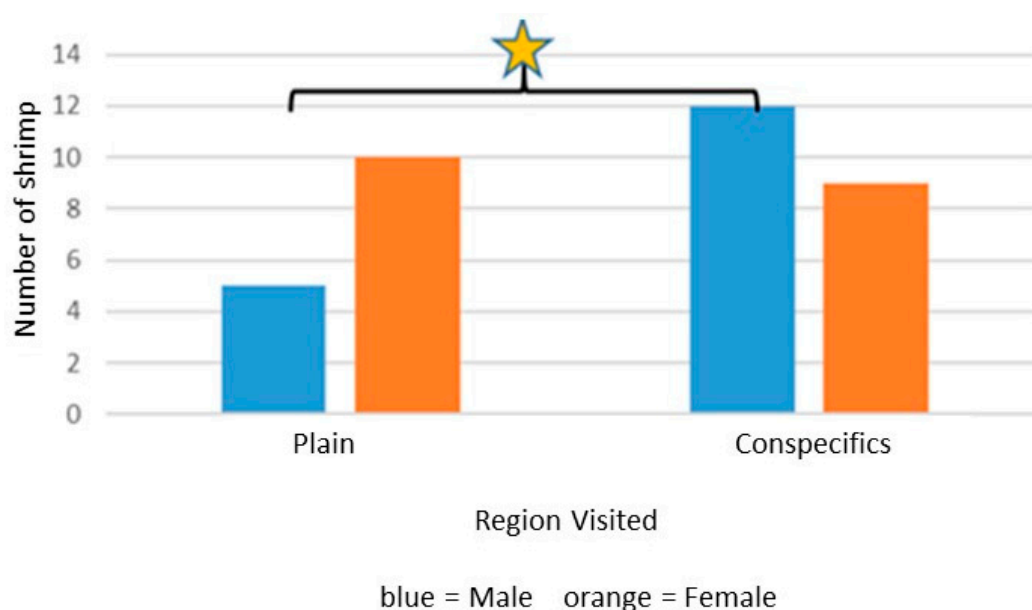




**Figure 7.** Number of *Latreutes fucorum* female shrimp that moved out of area C in the Y-maze for the control, *Sargassum*, DMSP 10<sup>-5</sup> M, DMSP 10<sup>-9</sup> M, and conspecific cue trials (binomial test; *Sargassum*,  $p = 0.11$ ; DMSP 10<sup>-5</sup>,  $p = 0.01$ ; DMSP 10<sup>-9</sup>,  $p = 0.02$ ; and conspecifics,  $p = 0.11$ ). Star/bracket indicates significant differences between indicated paired groups.



**Figure 8.** Number of *Leander tenuicornis* female shrimp that moved out of area C in the Y-maze for the control, *Sargassum*, DMSP, and conspecific cue trials (binomial test; *Sargassum*,  $p = 0.02$ ; DMSP,  $p = 0.05$ ; and conspecifics,  $p = 0.01$ ). Star/bracket indicates significant differences between indicated paired groups.



**Figure 9.** Initial choice in the Y-maze for the shrimp *Latreutes fucorum* between arm with the chemical cue vs. the arm with plain seawater in conspecific chemical cue trials based on sex (binomial test; males,  $p = 0.05$ ; females,  $p = 0.18$ ). Star/bracket indicates significant differences between indicated paired groups.

A paired  $t$ -test repeated-measures ANOVA for shrimp that moved in the maze showed no significance when comparing the time shrimp spent in the arm of the maze with the cue than without the cue, between the control, *Sargassum*, DMSP, and conspecific trials (all  $p > 0.05$ ).

#### 4. Discussion

##### 4.1. Four-Chambered Apparatus Trials

Results of these trials for *Latreutes fucorum*, overall, were similar to those in the 2009 study by Jobe and Brooks [3], which showed minimal response by the shrimp to chemical odors when visual cues were essentially unavailable. However, in our current study a post hoc  $t$ -test comparing shrimp movements in the presence of *Sargassum* odors showed a significant increase. This increase in movement did not show more shrimp specifically moving into the radial chamber with the *Sargassum* chemical source but rather more shrimp moved into all of the four radial chambers in the presence of *Sargassum* compared to the other treatments. This result suggests *L. fucorum* increased its general searching behavior but was not precise in locating the directional aspects of the chemical cue source.

This slight difference between the past study and the current study, both of which used the same shrimp species, apparatus, and chemical cue type, could be related to improvements made on the preparation of the chemical cue in this study. The earlier study used a single algal frond placed in the source water at the beginning of each trial. Whereas in the current study we soaked the algal frond in seawater for 48 h prior to the start of the trials. This significantly longer algal soaking period prior to testing could potentially produce a stronger chemical cue source concentration for the shrimp to detect. Additionally, our current study increased the replications for the 4-chambered trials from 10 (in the 2009 study) to 14, which could also potentially increase the likelihood of detecting a significant response. Due to these initial, relatively low responses, serial dilutions involving potentially weaker concentrations of *Sargassum* chemical cue were not tested for either apparatus.

##### 4.2. Y-Maze Apparatus Trials

Results of these trials for *Latreutes fucorum* and *Leander tenuicornis* were compelling in that they showed a clear ability of both shrimp species to detect and respond to chemical cues associated with *Sargassum* (including DMSP) and conspecifics. Such a strong response

with the Y-maze compared to outcomes with the 4-chambered apparatus (for *L. fucorum* only, due to limited availability of *L. tenuicornis*) are likely related to notable differences between the experimental procedures used with these two different types of apparatus. For example, each replicate for the 4-chambered apparatus used 30 individuals simultaneously, which means that conspecific cues from each sex were presumably readily available to each shrimp throughout those trials. Additionally, shrimp tested in groups may respond differently to shrimp tested individually. That is, movement and choices may be directly influenced by the chemical presence and direct behavior of conspecifics. Because of the high numbers of shrimp typically found in situ within *Sargassum* fronds (personal observation), it is likely that testing in groups is closer to natural conditions. However, the Y-maze has some advantages in that the number of movement choices by the shrimp is limited to two arms (versus four radial chambers) and chemical cues can be more highly controlled (e.g., conspecific, including sex, cues can be delivered individually).

In the Y-maze trials, several specific and significant responses by both shrimp species to chemical cues were observed. Although rarely was the significant difference in selection of the arm with the cue versus non-cue arm detected, there were several significant differences observed between where the shrimp were eventually located, i.e., comparing shrimp that stayed in the holding area C versus moving to either arm of the Y-maze.

Interestingly, significant responses in several instances were to actually move less than that observed in controls without chemical cues, while others involved directional movements toward the chemical odor source (but not necessarily selecting the arm with the chemical cue, i.e., increase in searching behavior but not necessarily locating the cue source, e.g., significantly more *L. fucorum* moved in the presence of both DMSP chemical cue concentrations). This dichotomy of chemical cues triggering search behavior decreases in some situations and increases in others will be discussed below for the different cues.

Significant responses to *Sargassum* for both shrimp species involved fewer individuals moving out of the holding area C. Additionally, fewer *L. tenuicornis* moved out of area C in the presence of conspecific chemical cues. *L. tenuicornis* is the larger of the two species of shrimp; therefore, interactions observed in the lab between conspecifics have occasionally been aggressive, especially larger shrimp towards smaller ones. In general, the shrimp seemed to disperse when kept together in a small container. Conspecific chemical cues for *L. tenuicornis* may have acted as a movement deterrent. For example, shrimp moving less in response to a conspecific chemical cue could be caused by conspecific shrimp releasing stress chemicals. A study on the crayfish *Procambarus clarkii* showed that individuals moved away from conspecifics because of the release of chemicals (i.e., stress cues) into the water [31]. In our study, handling of the shrimp when transferring them into the holding container (from which water dripped into an arm of the Y-maze) may have triggered the release of stress chemicals as well thereby affecting the response to conspecifics.

As pointed out previously, these shrimp are typically found in high concentrations in the fronds of *Sargassum*. Isolating a shrimp in the Y-maze may trigger anti-predator behavior. For example, the freshwater shrimp *Atya lanipes* will reduce its movement by up to 55% to avoid predation [32]. It is possible the chemical cues released from *Sargassum* effluents might have triggered a response to remain stationary. However, this would not explain why *L. fucorum* moved more in the presence of the DMSP cues. This contradiction could indicate the chemical cues released into the water from *Sargassum* are more complex than the single cue of DMSP (which presumably is released from *Sargassum*, too, along with other compounds).

This phenomenon of chemical cues triggering less search activity also occurred with *L. tenuicornis* when exposed to conspecific chemical cues. Perhaps such cues indicated to this shrimp that moving towards the source would involve interaction with additional individuals. Potential negative interactions (e.g., competition or aggression or stress chemicals released, as discussed above) among these shrimp are not well understood, even though they are found in high abundance in situ.

Alternatively, significantly more *L. fucorum* moved in the presence of both DMSP chemical cue concentrations. This demonstrates the possibility this cue could be used by shrimp in locating *Sargassum* patches, too.

Again, while an explanation of the variation of response for some chemical cues causing less shrimp movement by some and more movement for others is problematic, what is clear is that a significant difference in behaviors of the shrimp was observed for the chemical-cue treatments of *Sargassum*, DMSP and conspecifics. We were also able to further parse the significant movement differences related to the sex of the shrimp. Below, we have summarized the significant differences to the chemical cues based on shrimp species and sex.

*Sargassum* Cue: *L. fucorum* males and *L. tenuicornis* females moved significantly less in the Y-maze in the presence of the *Sargassum* chemical cue.

DMSP Cue: *L. fucorum* females moved statistically more in the Y-maze in the presence of both DMSP dilutions.

Conspecific Cue:

- a. *L. tenuicornis* females moved in the Y-maze statistically less in the presence of conspecific cues.
- b. *L. fucorum* males that moved in the Y-maze significantly chose the conspecific cue side initially.

A limitation of our study is that the shrimp were not sexed until after use in a trial. Because female shrimp are larger than males [33], when choosing shrimp from the holding aquarium, it is likely there was bias towards choosing females. This bias was especially noticeable for *L. fucorum* trials, as this species is smaller and difficult to locate. Additionally, only shrimp with a total length of 10 mm or greater were used in the Y-maze to ensure visibility in the recorded videos. This bias caused fewer males to be tested than females (*L. fucorum*, 1.88:1, female:male ratio; *L. tenuicornis*, 1.6:1, female:male ratio). Having lower replications for male shrimp decreases the power of statistical analyses, and limits conclusions that can be made about these results. Future studies may choose to incorporate all sizes of shrimp and more replicates with males. Doing so, however, may be problematic as handling smaller shrimp while preventing injury, etc., is challenging.

The two size groups of shrimp did not have any statistically different responses to any of the chemical cues tested (chi-square, all  $p > 0.05$ ). While this may suggest no difference in response between life history stages of the shrimp, future studies should attempt to record larval shrimp responses to chemical cues, as it may be more important for the larvae to detect patches and settle into the habitat. Larvae of other species of invertebrate rely heavily on habitat chemical cues for settlement. For example, swimming larvae of the hydrozoan *Coryne uchidai* settle in response to chemical cues from *Sargassum tortile* [34]. *L. fucorum* has a planktonic larval stage that lasts 18–30 days in the lab [35]. Such a long period of time would indicate that the larvae must have a means to locate suitable habitat.

In some cases, an organism responds to certain chemical cues as a larva but may lose the capability to detect the same chemical cues as an adult. Fiddler crab (*Uca* spp.) larvae can detect cues from food it typically consumes, but adults are insensitive to those same chemical cues [36]. Those results suggest that the life history stage of an organism may influence which chemical cues they respond to based on requirements of the organism at different stages in their life history.

## 5. Conclusions

*Sargassum* habitat is part of a significant marine, pelagic holobiont (i.e., host and collective symbionts), which is a complex and diverse community, much like a floating version of a coral reef. *Sargassum* is an Essential Fish Habitat [7], and entire food chains and marine ecosystems rely on the success of this community of symbionts. Understanding how these biotic connections are established and maintained is critical. This study focused on two shrimp species that are abundant in *Sargassum*; specifically, to expand on the previous

study by Jobe and Brooks [3] and clarify the role of available chemical cues for the shrimp to form and maintain their role in the *Sargassum* holobiont.

Unequivocally, we show that both *Latreutes fucorum* and *Leander tenuicornis* can detect and respond to chemical cues in the absence of visual cues from *Sargassum* patches. It is important to note that while chemoreception may be utilized, these shrimp are likely utilizing all senses available to maintain the association. As such, we envision that shrimp would use visual and chemical cues when both are available, as demonstrated by Jobe and Brooks [3], such as during the day and nights associated with full (or near) moons. The current results demonstrate responses to chemical cues exclusively could be important when visual cues are mostly limited. Additionally, both species of *Sargassum* shrimp are brooders and carry embryos until hatching [37]. Because the shrimp are hatched within the *Sargassum* patches, it is possible that planktonic larval and juvenile shrimp do not need to travel long distances to establish this symbiosis. However, natural disturbances such as storms and strong currents can disrupt and break apart *Sargassum* patches thereby potentially separating shrimp and other symbionts from their resident patch. This would require relocating patches for all ages and sizes of shrimp. Having access to both chemical and visual cues would seem advantageous.

A study on chemical feeding cues for *L. tenuicornis* found that only 5 out of the 28 single compounds used as cues were significantly stimulating the shrimp, which feed primarily on hydroids and bryozoans [38]. This shows that chemoreception can be highly specific, and thus searching for an organism's ability to use chemoreception may require testing several cues. Our study attempted to potentially isolate components of *Sargassum* by using DMSP, which did separately trigger responses. Differences in shrimp response between *Sargassum* and DMSP indicate that *Sargassum* effluents are likely highly complex, involving potentially multiple specific compounds. Future studies should conduct a chemical assay on *Sargassum* algae, potentially identifying more specific bioactive compounds that can be used to gain further insight into how this crucial mutualistic (alga supplies habitat and fish and shrimp provides nutrients via waste products); cf. [10], symbiosis is formed and maintained.

It is abundantly clear how important the shrimp are to the continuity of the *Sargassum* community. In addition to these shrimp species, several other *Sargassum* organisms have been studied. The *Sargassum* crab *Portunus sayi* is abundant in this community and was also found to detect *Sargassum* chemical cues [39]. When looking at both this current study and the previously mentioned studies on this community, it is clear that chemoreception is a major mechanism being used by several organisms in the *Sargassum* holobiont. Another study looked at habitat selection by both *L. tenuicornis* and the common fish species, *Histrio histrio*, and found that the organisms have preferred habitats based on structural complexity [8]. It is likely that all of these organisms are interconnected and play an important role in maintaining this symbiotic community, and the use of chemoreception is one vital component to the success of this symbiosis.

Finally, the *Sargassum* holobiont is in global crisis. Nutrient influx from anthropogenic sources has contributed to producing massive and sometimes harmful blooms of *Sargassum* that are not only potentially affecting the components within this ecosystem but have already profoundly affected coastal ecosystems [40] (Lapointe et al., 2021). It is more important than ever that we understand fully how *Sargassum* communities function.

**Author Contributions:** Conceptualization, J.L.F. and W.R.B.; methodology, J.L.F. and W.R.B.; software, J.L.F. and W.R.B.; investigation, J.L.F.; resources, J.L.F. and W.R.B.; writing—original draft preparation, J.L.F. and W.R.B.; writing—review and editing, J.L.F. and W.R.B. All authors have read and agreed to the published version of the manuscript.

**Funding:** This research received no external funding.

**Institutional Review Board Statement:** Not applicable.

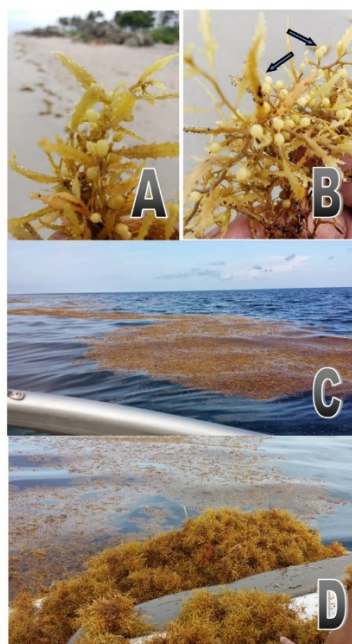
**Informed Consent Statement:** Not applicable.

**Data Availability Statement:** Data are unavailable as they are from a master student's thesis that is not available at this time.

**Acknowledgments:** We thank Rindy Anderson and John Baldwin for their logistical and technical support. We also thank Robert Dennis, Nicky Montagna, Tracy Frahm and Gary Frahm for their financial and general support.

**Conflicts of Interest:** The authors declare no conflict of interest.

## Appendix A



**Figure A1.** (A) indicates *Sargassum fluitans*. Notice smooth pneumatocysts (air bladders). (B) indicates *Sargassum natans*. Arrows indicate spines typically associated with pneumatocysts of this species. (C,D) show algal mats accumulating at sea surface and collected mats (D). Typically mats consist of both species shown in (A,B).

## References

1. Coston-Clements, L.; Settle, L.R.; Hoss, D.E.; Cross, F.A. *Utilization of the Sargassum Habitat by Marine Invertebrates and Vertebrates—A Review*; NOAA Technical Memorandum NMFS-SEFSC-296; National Oceanic and Atmospheric Administration: Washington, DC, USA, 1991.
2. Sehein, T.; Siuda, A.N.S.; Shank, T.M.; Govindarajan, A.F. Connectivity in the slender *Sargassum* shrimp (*Latreutes fucorum*): Implications for a Sargasso Sea protected area. *J. Plankton Res.* **2014**, *36*, 1408–1412. [[CrossRef](#)]
3. Jobe, C.F.; Brooks, W.R. Habitat selection and host location by symbiotic shrimps associated with *Sargassum* communities: The role of chemical and visual cues. *Symbiosis* **2009**, *49*, 77–85. [[CrossRef](#)]
4. Marmorino, G.O.; Miller, W.D.; Smith, G.B.; Bowles, J.H. Airborne imagery of a disintegrating *Sargassum* drift line. *Deep. Sea Res. Part I Oceanogr. Res. Pap.* **2011**, *58*, 316–321. [[CrossRef](#)]
5. Hu, C.; Murch, B.; Barnes, B.B.; Wang, M.; Maréchal, J.-P.; Franks, J.; Johnson, D.; Lapointe, B.; Goodwin, D.S.; Schell, J.M.; et al. *Sargassum* Watch Warns of Incoming Seaweed. *Eos* **2016**, *97*, 10–15. [[CrossRef](#)]
6. Niermann, U. Distribution of *Sargassum natans* and some of its epibionts in the Sargasso Sea. *Helgol. Mar. Res.* **1986**, *40*, 343–353. [[CrossRef](#)]
7. Ballard, S.E.; Rakocinski, C.F. Flexible Feeding Strategies of Juvenile Gray Triggerfish (*Balistes capricus*) and Planehead Filefish (*Stephanolepis hispidus*) Within *Sargassum* Habitat. *Gulf Caribb. Res.* **2012**, *24*, 31–40. [[CrossRef](#)]
8. Bennice, C.O.; Brooks, W.R. Habitat Selection among Fishes and Shrimp in the Pelagic *Sargassum* Community: The Role of Habitat Architecture. *Gulf Mex. Sci.* **2016**, *33*, 1. [[CrossRef](#)]
9. Brooks, W.R.; Hutchinson, K.A.; Tolbert, M.G. Pelagic *Sargassum* Mediates Predation among Symbiotic Fishes and Shrimps. *Gulf Mex. Sci.* **2007**, *25*, 5. [[CrossRef](#)]

10. Lapointe, B.E.; West, L.E.; Sutton, T.T.; Hu, C. Ryther revisited: Nutrient excretions by fishes enhance productivity of pelagic Sargassum in the western North Atlantic Ocean. *J. Exp. Mar. Biol. Ecol.* **2014**, *458*, 46–56. [[CrossRef](#)]
11. Stoner, A.W. Pelagic Sargassum: Evidence for a major decrease in biomass. *Deep. Sea Res. Part A Oceanogr. Res. Pap.* **1983**, *30*, 469–474. [[CrossRef](#)]
12. Lapointe, B.E. A comparison of nutrient-limited productivity in *Sargassum natans* from neritic vs. oceanic waters of the western North Atlantic Ocean. *Limnol. Oceanogr.* **1995**, *40*, 625–633. [[CrossRef](#)]
13. Wells, D.R.J.; Rooker, J.R. Spatial and temporal patterns of habitat use by fishes associated with Sargassum mats in the northwestern Gulf of Mexico. *Bull. Mar. Sci.* **2004**, *74*, 81–99.
14. Dooley, J.K. Fishes associated with the pelagic Sargassum complex, with a discussion of the Sargassum community. *Contrib. Mar. Sci.* **1972**, *16*, 1–32.
15. Rudershausen, P.J.; Buckel, J.A.; Edwards, J.; Gannon, D.P.; Butler, C.M.; Averett, T.W. Feeding Ecology of Blue Marlines, Dolphinfin, Yellowfin Tuna, and Wahoos from the North Atlantic Ocean and Comparisons with other Oceans. *Trans. Am. Fish. Soc.* **2010**, *139*, 1335–1359. [[CrossRef](#)]
16. Atema, J. Chemical signals in the marine environment: Dispersal, detection, and temporal signal analysis. *Proc. Natl. Acad. Sci. USA* **1995**, *92*, 62–66. [[CrossRef](#)] [[PubMed](#)]
17. Carr, W.E.S.; Ache, B.W.; Gleeson, R.A. Chemoreceptors of Crustaceans: Similarities to Receptors for Neuroactive Substances in Internal Tissues. *Environ. Health Perspect.* **1987**, *71*, 31–46. [[CrossRef](#)]
18. Brooks, W.R.; Rittschof, D. Chemical Detection and Host Selection by the Symbiotic Crab *Porcellana sayana*. *Invertebr. Biol.* **1995**, *114*, 180. [[CrossRef](#)]
19. Díaz, E.R.; Thiel, M. Chemical and Visual Communication During Mate Searching in Rock Shrimp. *Biol. Bull.* **2004**, *206*, 134–143. [[CrossRef](#)]
20. Dacey, J.W.H.; Wakeham, S.G. Oceanic Dimethylsulfide: Production During Zooplankton Grazing on Phytoplankton. *Science* **1986**, *233*, 1314–1316. [[CrossRef](#)]
21. Hill, R.; Dacey, J. Metabolism of dimethylsulfoniopropionate (DMSP) by juvenile Atlantic menhaden *Brevoortia tyrannus*. *Mar. Ecol. Prog. Ser.* **2006**, *322*, 239–248. [[CrossRef](#)]
22. Broadbent, A.; Jones, G.; Jones, R. DMSP in Corals and Benthic Algae from the Great Barrier Reef. *Estuar. Coast. Shelf Sci.* **2002**, *55*, 547–555. [[CrossRef](#)]
23. DeBose, J.L.; Lema, S.C.; Nevitt, G. Dimethylsulfoniopropionate as a Foraging Cue for Reef Fishes. *Science* **2008**, *319*, 1356. [[CrossRef](#)]
24. Nevitt, G.A.; Veit, R.R.; Karieva, P. Dimethyl sulfide as a foraging cue for Antarctic procelariiform seabirds. *Nature* **1995**, *376*, 680–682. [[CrossRef](#)]
25. Kowalewsky, S.; Dambach, M.; Mauck, B.; Dehnhardt, G. High olfactory sensitivity for dimethyl sulphide in harbour seals. *Biol. Lett.* **2005**, *2*, 106–109. [[CrossRef](#)] [[PubMed](#)]
26. Hay, M.E. Marine chemical ecology: What's known and what's next? *J. Exp. Mar. Biol. Ecol.* **1996**, *200*, 103–134. [[CrossRef](#)]
27. DeBose, J.L.; Nevitt, G.A.; Dittman, A.H. Rapid Communication: Experimental Evidence that Juvenile Pelagic Jacks (Carangidae) Respond Behaviorally to DMSP. *J. Chem. Ecol.* **2010**, *36*, 326–328. [[CrossRef](#)] [[PubMed](#)]
28. Vila-Costa, M.; Rinta-Kanto, J.M.; Poretsky, R.S.; Sun, S.; Kiene, R.P.; Moran, M.A. Microbial controls on DMSP degradation and DMS formation in the Sargasso Sea. *Biogeochemistry* **2014**, *120*, 295–305. [[CrossRef](#)]
29. Cox, D. The Role of Chemical Cues in Locating Pelagic Sargassum by the Associated Fish *Stephanolepis hispidus*. Master's Thesis, Florida Atlantic University, Boca Raton, FL, USA, 2016.
30. Penha-Lopes, G.; Torres, P.; Macia, A.; Paula, J. Population structure, fecundity and embryo loss of the sea grass shrimp *Latreutes pymoeus* (Decapoda: Hippolytidae) at Inhaca Island, Mozambique. *J. Mar. Biol. Assoc. UK* **2007**, *87*, 879–884. [[CrossRef](#)]
31. Schneider, R.Z.; Moore, P. Urine as a source of conspecific disturbance signals in the crayfish *Procambarus clarkii*. *J. Exp. Biol.* **2000**, *203*, 765–771. [[CrossRef](#)]
32. Crawl, T.A.; Covich, A.P. Responses of a Freshwater Shrimp to Chemical and Tactile Stimuli from a Large Decapod Predator. *J. N. Am. Benthol. Soc.* **1994**, *13*, 291–298. [[CrossRef](#)]
33. Martínez-Mayén, M.; Román-Contreras, R. Some Reproductive Aspects of *Latreutes fucorum* (Fabricius, 1798) (Decapoda, Hippolytidae) from Bahía De La Ascensión, Quintana Roo, Mexico. *Crustaceana* **2011**, *84*, 1353–1365. [[CrossRef](#)]
34. Kato, T.; Kumanireng, A.S.; Ichinose, I.; Kitahara, Y.; Kakinuma, Y.; Kato, Y. Structure and synthesis of active component from a marine alga, *Sargassum tortile*, which induces the settling of swimming larvae of *Coryne uchidai*. *Chem. Lett.* **1975**, *4*, 335–338. [[CrossRef](#)]
35. Bailey, D.J. The Larval Development of the Sargassum Shrimps *Leander tenuicornis* (Say) (Palaemonidae) and *Latreutes fucorum* (Fabricius) (Hippolytidae) Reared in the Laboratory. Master's Thesis, Florida Atlantic University, Boca Raton, FL, USA, 1980.
36. Weissburg, M.J.; Zimmer-Faust, R.K. Ontogeny Versus Phylogeny in Determining Patterns of Chemoreception: Initial Studies with Fiddler Crabs. *Biol. Bull.* **1991**, *181*, 205–215. [[CrossRef](#)]
37. Bauer, R.T. Continuous reproduction and episodic recruitment in nine shrimp species inhabiting a tropical seagrass meadow. *J. Exp. Mar. Biol. Ecol.* **1989**, *127*, 175–187. [[CrossRef](#)]
38. Johnson, B.R.; Atema, J. Chemical stimulants for a component of feeding behavior in the common gulf-weed shrimp *Leander tenuicornis* (Say). *Biol. Bull.* **1986**, *170*, 1–10. [[CrossRef](#)]

- 
39. West, L.E.; Brooks, W.R. Habitat location and selection by the symbiotic *Sargassum* crab *Portunus sayi*: The role of chemical, visual, and tactile cues. *Symbiosis* **2018**, *76*, 177–185. [[CrossRef](#)]
  40. Lapointe, B.E.; Brewton, R.A.; Herren, L.W.; Wang, M.; Hu, C.; McGillicuddy, D.J.; Lindell, S.; Hernandez, F.J.; Morton, P.L. Nutrient content and stoichiometry of pelagic *Sargassum* reflects increasing nitrogen availability in the Atlantic Basin. *Nat. Commun.* **2021**, *12*, 1–10. [[CrossRef](#)] [[PubMed](#)]