

Article

# Applications of Complex Network Analysis in Electric Power Systems

Mahmoud Saleh <sup>1</sup>, Yusef Esa <sup>1</sup> and Ahmed Mohamed <sup>1,2,\*</sup> 

<sup>1</sup> Department of Electrical Engineering, The City University of The City College of New York, New York, NY 10031, USA; mahmoudsah@hotmail.com (M.S.); yusefesa@gmail.com (Y.E.)

<sup>2</sup> Department of Electrical Engineering (on leave), Menia University, Menia 61512, Egypt

\* Correspondence: amohamed@ccny.cuny.edu

Received: 14 March 2018; Accepted: 21 May 2018; Published: 29 May 2018



**Abstract:** This paper provides a review of the research conducted on complex network analysis (CAN) in electric power systems. Moreover, a new approach is presented to find optimal locations for microgrids (MGs) in electric distribution systems (EDS) utilizing complex network analysis. The optimal placement in this paper points to the location that will result in enhanced grid resilience, reduced power losses and line loading, better voltage stability, and a supply to critical loads during a blackout. The criteria used to point out the optimal placement of the MGs were predicated on the centrality analysis selected from the complex network theory, the center of mass (COM) concept from physics, and the recently developed controlled delivery grid (CDG) model. An IEEE 30 bus network was utilized as a case study. Results using MATLAB (MathWorks, Inc., Natick, MA, USA) and PowerWorld (PowerWorld Corporation, Champaign, IL, USA) demonstrate the usefulness of the proposed approach for MGs placement.

**Keywords:** centralized control; complex network analysis (CNA); controlled delivery grid; grid resilience; microgrids placement

## 1. Introduction

Scientists in many fields have, through the years, established extensive tools, mathematical, computational, and probabilistic, aimed at scrutinizing, modeling, and understanding different networks. The study of network science predicated its basic foundations on the development of graph theory, which was early examined by Leonhard Euler in 1736, when he published the famous Seven Bridges of Königsberg paper [1]. In the context of the network theory, a complex network could be defined as a graph that is composed of relatively many mutually related nodes (e.g., structural or functional relation) [2,3]. It could also be defined as a network that has non-observable topological features that do not arise in simple networks such as random ones, but often occur in graph models of real systems [4]. Based on the former description, electric power systems can be classified as complex networks and investigated through the lens of CNA [5,6]. The electric power system is categorized one of the most critical infrastructures. It is going through significant changes driven by the aging of the centralized energy infrastructure while electricity demand is growing [7], and the worldwide determination to reduce CO<sub>2</sub> emissions [8,9]. Moreover, recent natural disasters, such as Hurricane Sandy, exposed some of the power system's weaknesses. Therefore, a national call to enhance the grid's resilience and self-healing abilities was raised [10]. This led to the imperative upgrade to the "smart grid", with a key role expected to be played by MGs. In order to maximize the benefits of MGs within the electric power system, MGs placement is an essential feature to examine.

Recently, many states have started to announce competitions and prizes regarding microgrid implementation to promote clean energy and increase grid resilience. For example, in July 2017,

the New Jersey Board of Public Utilities decided to deploy 13 new MGs statewide in an attempt to maximize their resilience in the face of catastrophic weather events. The board president announced that the Board's Town Center Distributed Energy Resource (DER) MG program is funding feasibility studies/research for 13 separate proposed town center MGs across New Jersey [11,12]. A similar prize in New York has been announced as well. Moreover, microgrid implementation is also driven by federal and state regulatory actions to encourage Non-Wire Solutions (NWS) and reduce greenhouse gas (GHG) emissions from new and existing power plants. In order to maximize the resilience of the electric power grid in these states during the planning stage, one main aspect should be considered and investigated, which is the microgrid's placement. Microgrid locations will contribute to maximizing the power grid's resilience during a blackout and should perform the following tasks: (1) supply most of the critical loads within the distribution network; (2) maintain voltage within acceptable limits; (3) operate within the line loading capacities; (4) and minimize system losses. In order to attempt to solve the aforementioned problem, one can think of a "trial and error" approach, i.e., if  $N$ -microgrids are to be implemented in an  $M$ -buses system, then we are looking at  $N^M$  trails to determine the microgrid locations that will enhance the system resilience (e.g., implementing three microgrids in a 30 bus system will lead to  $3^{30} = 2.06 \times 10^{14}$  trials). Not including the processing time, the whole procedure will require a tremendous amount of time to find optimal locations, especially in big systems. Therefore, another approach that can provide pointers regarding the plausible optimal locations should be explored.

Preceding research concentrated on finding the optimal location of distributed generation within an MG using metaheuristic means to minimize network losses [13]. Some of the performed research used complex network similarity with the electric power system to look into transient stability assessment [5,6]. Others used game theory to economically investigate the transfer of energy between distributed energy resources within an intelligent distribution system [14]. Researchers in [15] tried to coordinate the injection of the reactive power of photovoltaic generators to regulate the distribution network voltage without having to integrate new components and consequently eliminate the additional costs. Also, research was conducted in [16] to find the optimal reconfiguration of a distribution network (i.e., self-sustainable islands/MGs or sub-area partitioning) to maximize the energy savings. In [17], the research was focused on managing the power exchange between MGs during emergencies to keep all of them operational. We used the CDG model developed in [18,19] to enhance the EDS resilience with a high penetration of MGs in [20]. The CDG model suggests full observability and control of the loads by a central controller (i.e., distribution system operator (DSO)) that processes "requests" (i.e., demands) from all loads and yield back "grants" (i.e., power) according to an energy management algorithm (EMA).

In this paper, abstract and weighted complex network frameworks have been established for a modified IEEE 30 bus system, along with utilizing the COM concept and centrality analysis, to determine the plausible optimal locations to deploy microgrids within electric distribution systems. The real-time energy management based on the CDG model, presented in [20], was used as an operational EMA for the distribution system operator (DSO) to evaluate the resilience aspect of the proposed locations from the developed complex network framework. In other words, the EMA implemented in the DSO takes into account the operational conditions (e.g., voltage variations, congestion limits, etc.). The input to the DSO is the available energy from the MGs and the load requests. The DSO tries to find the solution that has the fewest losses and highest grant/request ratio and is within the acceptable operational limits. Also, this paper aimed to provide an extensive review of previously conducted research that attempted to analyze the electric power system using complex networks theory. It should be mentioned that some practical limitations were not considered during the analysis such as the location availability.

## 2. Literature Survey

We attempted to scrutinize the electric power systems from two main points of view: (1) an abstract perspective (i.e., as a graph consists from nodes and edges), regardless of the electric power aspects (e.g., transmission line impedances); (2) weighted graphs that blend an abstract understanding of complex network theories and electric power systems.

### 2.1. Examining the Electric Power System from an Abstract Perspective

Recent advancements in mapping the topology of abstract complex networks have revealed that a large segment of them are extremely heterogeneous with respect to the degree of the nodes (i.e., the number of edges connected directly to a node) [21]. In complex networks, most of the nodes have a low degree, but there is a continuous hierarchy of high degree nodes called “hubs”, which play a significant role in the network. According to the node degree distribution of the complex network, the system can be classified as a scale-free or single-scale network. Scale-free networks have most of their nodes with a low degree and some nodes are hubs; the node degree distribution of these networks follows a power law  $P(k) \sim k^{-\gamma}$  with an exponent  $\gamma$  that mostly ranges between a value of two and three, where  $k$  is the node degree. Single-scale networks, in the context of power systems indicate that there is a path of transmission lines (TLs) between any power plant and any distribution substation; these networks can be considered regular networks where every node has roughly the same degree. Scientists examining and assessing the vulnerabilities of complex networks are usually interested in deciding whether the system under study is a single-scale or scale-free network. One of the reasons is that, for example, scale-free networks are more resilient to the random disconnection of nodes; however, they are vulnerable to targeted attacks on hubs [22–24].

From a power system perspective, it is very important to examine whether the connectivity of the electric power grid is dependent on a small set of hubs and if their disconnection might initiate an extensive obstruction of the power transmission capabilities (e.g., a blackout).

Researchers in [21] investigated the North American power grid from an abstract complex network point of view and tried to determine its ability to transfer power between generation and distribution when specific nodes are disconnected. The work attempted to model this power grid based on the data stored in the mapping system developed by Platts [25]. This mapping system comprises data regarding every power plant, major substation, and 115–765 kV TLs of the North American power grid. The model developed represents the North American electric grid as a network that contains approximately 14,000 nodes (i.e., substations) and 19,000 edges (i.e., transmission lines). Some of the significant findings of this work are as follows:

- The cumulative degree distribution of the North American grid follows an exponential function  $P(k > K) \sim e^{-0.5K}$ , which agrees with that of the Western power grid that is categorized as a single-scale network.
- The cumulative betweenness node distribution follows  $P(l > L) \sim (2500 + L)^{-0.7}$ . The betweenness ( $l$ ) of a node in a network is defined as the number of shortest paths that pass through it [26,27]. Assuming that the power is sent through the shortest route, the betweenness of a substation could be considered as an indication of how much energy passes through it. The calculated betweenness node distribution demonstrates that almost 40% of the substations are part of tens and hundreds of shortest paths, while 1% of the substations lie on a million or more shortest paths. These high betweenness substations, even though they may not be considered hubs, have a significant role in power transmission.
- To ensure the reliability of the loads being continuously supplied, the transmission network of the electric power grid was designed in such a way that there is more than a single electrical line between any two substations. In an attempt to verify whether the North American grid topology has this characteristic of global redundancy or has vanished through the grid expansions, the authors presented a measure of the network redundancy called the

“edge range”. This measure is defined as the distance between the ends of an edge if the edge linking them was removed [28]. It was found that around 900 TEs connecting generators and/or transmission substations are radial. These radial TEs represent a clear weakness, as their disconnection isolates their endpoints and subsequently creates islanded clusters in the electric power grid.

- Degree-based and random disconnection of nodes was performed to examine the connectivity loss percentage, which quantifies the average reduction in the number of generators connected to a specific distribution substation. Through this experiment, it was found that the elimination of generating substations does not change the overall connectivity of the grid due to the high level of redundancy at the generating substation level. However, the situation can be radically different when the substations being disconnected were transmission substations. For accidental or random disconnection, the connectivity loss is considerably low and remains proportional to the number of nodes that got disconnected. On the other hand, the connectivity loss is significantly increased when high betweenness or high degree transmission hubs are disconnected. In their conclusion, the electric grid can endure only a few failures of this type before substantial parts of the grid become separated, leading to a significant connectivity loss at the distribution level. For example, the failure of 4% of the substations that have high betweenness might lead to a 60% loss of connectivity in the grid.

Similar work was conducted on the Italian power grid for the 220 and 380 kV transmission lines, which includes 341 substations and 517 transmission lines [29]. The aim of the study was to show that the structure of the power grid could reveal important information regarding the vulnerability of the network under cascading failures. In this study, the weights of the transmission lines were updated after disconnecting a node or line such that if the load in a line exceeds its capacity, the weight will be varied by a factor equal to the capacity divided by the line loading. The calculated cumulative node degree distribution of the Italian grid was calculated to be equal to  $2.5 e^{-0.55k}$  and the cumulative betweenness node distribution follows  $(785 + l)^{-1.44}$ , which indicates that this grid is very homogeneous regarding the node degree distribution and shows a high heterogeneity in the nodes' betweenness. The authors found that the node degree and betweenness are not correlated and that the failure of high betweenness nodes is more significant and could lead to large-scale blackouts. Moreover, they studied the impact of increasing the line capacity (e.g., 1.2~1.5 times) on the initiation of a cascading failure and found that there was no substantial difference in the results. Following the same type of scrutiny, Casals et al. [30] examined the structural topology of the European electric grid and its tolerance to targeted and accidental failures. In another work, Sole et al. [31] explored the fragility of the European electric power grid under targeted attacks, where specific substations in the network were disconnected and the patterns of failures were analyzed. Coelho et al. conducted the same analysis on a Brazilian test system [32].

In 1998, Watts and Strogatz proposed the small-world phenomenon in network models. The small-world networks exhibit a high clustering coefficient similar to that in regular networks and a small average distance like random networks. Through the formulation procedure of the small-world network, it is noticeable to see that it is the few long edges (i.e., edges that connect nodes to another far away ones) that make small-world networks different from both random and regular networks. The main reason is that nodes' distances have been significantly shortened since the shortest paths generally pass through those long edges. As a result, the nodes connected by long edges in the network have higher betweenness centrality than of the other nodes. Also, in case these nodes are being disconnected intentionally (e.g., attacked) the structure of the network should greatly change (e.g., more islands might be created) [33]. Researchers in [34] analyzed the north part of the Chinese national grid and found that the normalized distribution of the lengths of its shortest paths is similar to that of the West State Power Grid (WSPG) in the United States and tried to show it is a small-world network as well.

Most of these studies focus only on the abstract structure of the power grid using node degree distribution and betweenness distribution, which introduces substantial insight regarding the vulnerability assessment of the grid. Also, these studies are considered a foundational building block in establishing theoretical probability models for the cascading failures research in the power grids. Other research tried to examine whether the electric power grid understudy is a small-world phenomenon by utilizing the properties of centrality and path lengths in an attempt to study the vulnerability of the system and its tendency to form islands [35–37]. However, no cohesive study on an electric power grid has been conducted that keeps all of these parameters in perspective through the analysis.

Through these types of studies, the category of the grid structure could be identified from the complex network perspective (e.g., single-scale, scale-free). This classification might help the electric power system engineers in the planning stage or while upgrading the infrastructure (e.g., add a new transmission line) to maintain a proper redundancy level in the transmission system.

## 2.2. Scrutinizing the Electric Power System Utilizing Weighted Graphs

Numerous measures/indices could be developed that could specify certain features of the network, if the structure of the network is known. Social scientists have used some centrality indices [38–41] to better explain a person's impact within a network. Among these centrality indices, the most widely used in the electric power systems are degree centrality and betweenness centrality, as mentioned earlier. However, for further in-depth analysis, selected electric power system parameters need to be included (e.g., relate the weight of the edges to a group of electric power system properties) according to the type of study being conducted [42].

Ian Dobson from Iowa State University is considered one of the pioneers in investigating power system blackouts initiation and propagation using probabilistic complex network analysis models and finding the feature of self-organized criticality of the electric power grid [43–48]. Motter and Lai [28] showed how the redistribution of loads on substations due to the failure of certain important substations or TLs can result in a cascading failure. Dwivedi and Yu explore the idea of vulnerability analysis of power systems using maximum power flow-based centrality in [49]; the study was done on the IEEE 39 bus system. Their work presented a new direction for identifying important links in structural vulnerability analysis [50]. Nasiruzzaman et al. in [51] attempted to identify the critical nodes within the system using the conventional centrality measures of complex networks and the line weights were based on the electric grid impedances and power flow. Moreover, Nasiruzzaman and Pota in [5] conducted transient stability assessment utilizing the betweenness index and the power flow as the weight of the lines. Also, Chen et al. [52] introduced a bus admittance matrix into the traditional topological model, as weights of the TLs, for the purpose of further studying power grid vulnerability. Arianos et al. [53] presented a complex network-based parameter called net-ability to evaluate the performance of power grids during normal operation. Fang et al. in [54] investigated the cascading failure behavior using directed complex networks. They performed two attack strategies on the IEEE 118 bus network, namely “minimum in-degree”, which refers to the intentional attack to the input link of the node with the minimum in-degree; and “maximum out-degree”, which refers to the intentional attack on the input link of the node with the maximum out-degree. Their work concluded the following: (1) the cascading failure impact could be minimized by increasing the line capacity by a tolerance factor; and (2) an initial small-scale fault may result in a complete power outage of the network when the tolerance factor is small.

All the aforementioned efforts have shed light on exploring the electric power system from a new perspective through the complex network lens, which led to significant findings, especially regarding grid vulnerability assessments. However, there is no commonly accepted approach that involves complex network analysis in conventional power system analysis.

In subsequent sections, the use of complex network analysis to find a plausible optimal location to implement microgrids within a distribution system will be demonstrated.

### 3. System Understudy

The system being studied is presented in Figure 1. It shows the IEEE 30 bus system. The buses and lines data were extracted from [55]. The network was altered to represent a power outage condition by removing the main infeed from the grid. The network is divided into three areas, namely Areas 1, 2, and 3, each with a different load profile, as can be seen in Figure 1. The aggregated demand is 283.4 MW, and 126.2 MVar. We assumed that the three MGs are connected to the system at three different buses. The rated available apparent power during the 24 h,  $\{P_i, Q_i\}$ , for these three MGs is  $\{80, 50\}$ ,  $\{80, 30\}$  and  $\{50, 20\}$  MW and MVar, respectively.

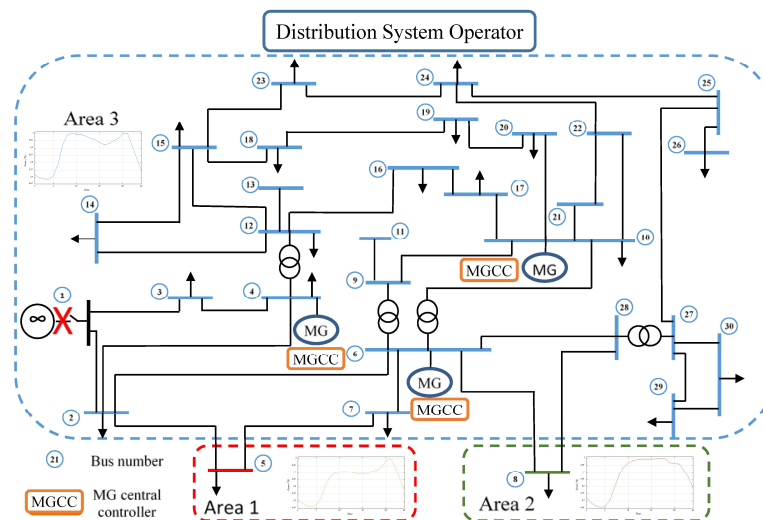

Figure 1. Modified IEEE 30 bus system.

Each bus has a local controller. These controllers, in the case of load buses, send load requests to the DSO and also have the ability to execute load shedding on their controllable loads. In the case of microgrid buses, these local controllers represent the Microgrid Central Controllers (MGCCs) and send generation permissions as shown in Figure 2. The microgrid could represent a group of resources (wind turbines, solar farm, diesel generators, etc.) along with energy storage systems (batteries, flywheels, etc.). Also, it could be thought of as a cluster of MGs managed by one controller. The DSO does not need to have prior knowledge about the details of the MGs. The MGCC checks its resources and loads then only send a signal representing the possible available power that the MG could supply. The footprint of the IEEE 30 bus system is more than 100 km<sup>2</sup> [56]. A single microgrid could supply several megawatts, such as UCSD MG in California, which supplies ~31.2 MW to a 4 km<sup>2</sup> campus; New York University MG, which has a capacity of 13.4 MW to supply 22 buildings; and Illinois Institute of Technology MG, which has a collective DERs capacity close to 9 MW [57].

The central controller (i.e., DSO) executes the EMA in [20]. The brute force algorithm looks for a solution that agrees with all the constraints (i.e., acceptable voltage limits, line capacities and minimum losses) and allows all the requested demands to be granted. If the algorithm does not find a possible solution, it has to find another solution, with some of the requests not being fully supplied (i.e., load shedding). It was assumed that each bus controller will send a demand request, in the form of a signal that comprises four load levels with a 10% difference or more. The grant signal from the DSO will be based on a priority list in [20]. The priority has been assigned such that Area 3 has the lowest priority and Area 1 has the highest. In other words, the DSO will try to grant all the requested demands. If that is not feasible, it will execute the brute force algorithm for a reduced demand, based on their priorities. In this paper, the locations of the MGs that will enhance the DSO operation will be further scrutinized using the complex networks framework, which will be explained in the subsequent section.

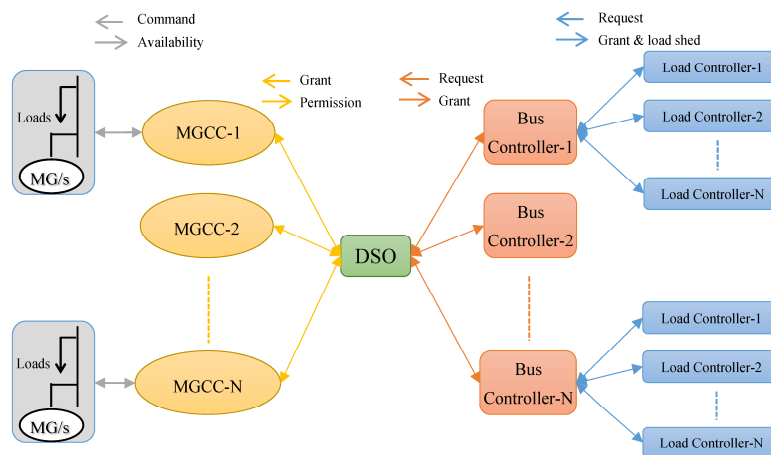

Figure 2. Grant/request process in the distribution network.

#### 4. Complex Network Framework

In order to inspect an electric grid utilizing the CNA, the first step is to model this grid as a graph (i.e., TLs as edges and the buses as nodes). Figure 3 displays the equivalent graph of the IEEE 30 bus network. It contains 30 nodes (i.e., vertices) and the TLs are shown by 41 edges, which link the network nodes. Through this paper, we tried to use the complex network framework in the grid abstract form (i.e., undirected and unweighted) to learn about the central buses/nodes from a connectivity point of view. Moreover, we used different weights for the network edges (i.e., TLs) to understand the impact of electric system parameters such as normalized impedances and the centrality of nodes. Three main features were chosen to understand the nodes' centrality in the IEEE 30 bus network: the clustering coefficient, betweenness and closeness centrality. Betweenness centrality could be defined as the number of shortest paths between all vertices (i.e., buses) that go through this vertex. It is utilized as a main measure of centrality [58] (i.e., a node with higher betweenness will have more impact over the system). The weights of the edges in betweenness were selected to be the normalized admittance of the TLs such that it becomes more correlated to the network power flow. In other words, the greater the lines admittances linked to a node, the greater the odds that the power will flow through this node. Betweenness can be calculated using Equation (1):

$$c(v) = \sum_{s,t \neq v} \frac{n_{st}(v)}{N_{st}}, \quad (1)$$

where  $n_{st}(v)$  is the number of shortest paths between vertices  $s$  and  $t$  that pass by the vertex  $v$ , and  $N_{st}$  is the overall number of shortest paths between vertices  $s$  and  $t$ . Closeness centrality could be defined as the average of the shortest paths between specific node and the rest of the nodes in the network [59]. The increase in node closeness indicates how near it is to the other nodes. The shortest electric route is the one that has the minimum resistance. Therefore, the edges' weights were chosen to be the normalized impedance, since closeness is more associated with distance. Closeness can be calculated using Equation (2):

$$c(i) = \left( \frac{v_i}{N-1} \right)^2 \frac{1}{C_i}, \quad (2)$$

where  $v_i$  is the number of nearby vertices from vertex  $i$  (not including  $i$ ),  $N$  is the number of vertices in any graph  $G$ , and  $C_i$  is the overall sum of distances from vertex  $i$  to all nearby vertices. If there is no path from vertex  $i$  to the nearby vertices, then  $c(i)$  is zero.

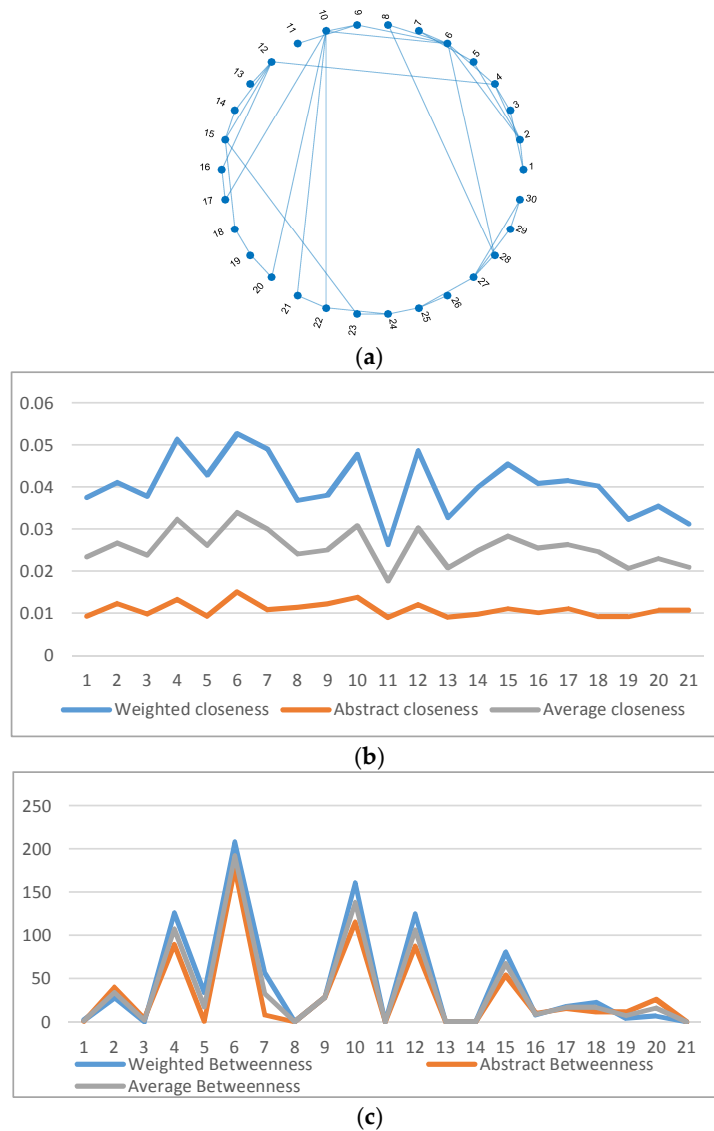

**Figure 3.** Shows the IEEE 30 bus network: (a) graph; (b) Closeness centrality; (c) Betweenness centrality.

The clustering measure is an index that evaluates which vertices in a graph will cluster together. The local clustering coefficient (LCC) of a node computes the average connections of its nearby nodes. The LCC for each node and the overall CC of the network can be calculated as in Equations (3) and (4), respectively:

$$CC(v) = \frac{2 N_v}{K_v(K_v - 1)} \tag{3}$$

$$CC(G) = \frac{1}{n} \sum_{i=1}^n C_i \tag{4}$$

where  $N_v$  is the number of edges between vertex  $v$  nearby nodes and  $K_v$  is the vertex degree.

The LCC was calculated to examine the clustering tendency of the IEEE 30 bus. In addition, from the power system point of viewpoint, a bus having a high CC might indicate that if it gets separated, the power flow will have alternative paths to the nearby buses. In other words, a high LCC could indicate a less central bus, but this is not enough as a self-indicator. The overall CC was calculated for the 30 bus system as 0.234. It is equal to one (i.e., clique [60]) if all the vertices in the graph are linked to one another.



It can be observed from the CNA in Table 1 that buses 4, 6 and 10 have more effect than the others. It can also be seen in Figure 3b,c. However, if the COM analogy is utilized to find the load center using Equations (5) and (6), bus number 5 will be the closest one to the load center. In the next section, it will be shown that the location of the MGs placement impacts the operation of the DSO.

$$x_l = \frac{\sum_{i=1}^n L_i x_i}{\sum_{i=1}^n L_i} \quad (5)$$

$$y_l = \frac{\sum_{i=1}^n L_i y_i}{\sum_{i=1}^n L_i}, \quad (6)$$

where  $x_l$  and  $y_l$  are the coordinates of loads center,  $L_i$  is the load associated with bus  $i$ , and  $n$  is the number of buses in the system. Weighted closeness centrality.

**Table 1.** Results conducted using complex network analysis (CAN) in a complex network framework.

Centrality Type	Closeness Centrality		Average Closeness	Betweenness		Average Betweenness	CC	
	Weights	Z	Abstract	-	1/ Z	Abstract		-
Bus No.								
1		0.03757	0.009346	0.023458	2	1	1.5	0
2		0.04114	0.012346	0.026743	28	40.5	34.25	0.166667
3		0.037896	0.009901	0.023898	0	4	2	0
4		0.051342	0.013333	0.032338	126	89.75	107.875	0.166667
5		0.04297	0.009346	0.026158	34	1	17.5	0
6		0.052748	0.015152	0.03395	208	176.5833	192.2917	0.142857
7		0.049101	0.01087	0.029985	57	8.5	32.75	0
8		0.036862	0.011364	0.024113	0	0	0	1
9		0.038094	0.012195	0.025145	28	28	28	0.333333
10		0.047808	0.013889	0.030848	161	115.6667	138.3333	0.133333
11		0.026385	0.009091	0.017738	0	0	0	0
12		0.048605	0.012048	0.030326	125	87.5	106.25	0.1
13		0.032721	0.009009	0.020865	0	0	0	0
14		0.04005	0.009804	0.024927	0	0	0	1
15		0.045568	0.011111	0.02834	81	54	67.5	0.166667
16		0.040794	0.010101	0.025447	8	10.41667	9.208333	0
17		0.041507	0.011111	0.026309	18	15.91667	16.95833	0
18		0.040242	0.009174	0.024708	23	11.41667	17.20833	0
19		0.03232	0.009174	0.020747	4	11.41667	7.708333	0
20		0.035456	0.010753	0.023104	7	26.25	16.625	0
21		0.031265	0.010638	0.020952	0	0	0	1
22		0.037667	0.011765	0.024716	42	34.91667	38.45833	0.333333
23		0.036848	0.010309	0.023579	24	31.25	27.625	0
24		0.030453	0.011111	0.020782	54	56.41667	55.20833	0
25		0.025163	0.010101	0.017632	37	48.83333	42.91667	0
26		0.017861	0.007874	0.012868	0	0	0	0
27		0.024411	0.010638	0.017525	54	76.83333	65.41667	0.166667
28		0.044617	0.012346	0.028481	63	72.83333	67.91667	0.333333
29		0.019412	0.008264	0.013838	0	0	0	1
30		0.020425	0.008264	0.014345	28	0	14	1

## 5. Results and Analysis

The MG placements decided by the CNA and the COM (i.e., placed in between the most loaded buses) have been evaluated utilizing the IEEE 30 bus system in Figure 1. The network is undergoing a blackout that happened as a result of the disconnection of the main infeed from bus 1. Three different sets of places for the MGs were chosen to demonstrate their effect on the real-time EMA based on the CDG model in [21] and the resilience of the EDS.

The COM analogy showed that the load center is near to bus 5, and therefore buses 5, 3 and 10 were chosen to be the set of places/locations (L1) to connect the three MGs. Buses 3 and 10 were chosen alongside bus 5 to assure that the MGs are spread over the IEEE 30 bus system. Sets of places (L2) were

chosen to be buses 27, 29 and 30, which have the highest CC according to CNA. Set of places (L3) were chosen to be buses 4, 6, and 10, which have the highest betweenness and closeness centralities among the other buses, as explained in Section 4.

Figure 4 illustrates the effect of locating the MGs at L1. Figure 4a–c depicts the normalized requested demands, and the power granted for 24 h at Areas 1, 2, and 3, respectively. The number of the bus selected by the EMA to be the swing bus is displayed hourly. Similarly, Figures 5 and 6 show the impact of locating the MGs at L2 and L3, respectively.

Comparing Figures 4–6, it demonstrates that location L3, which is proposed by the CNA, has the highest yield (i.e., grant/request) in all the areas (i.e., more loads were being supplied during the power outage). Moreover, the results in Figure 5 demonstrate that higher CC does not imply optimal placement. Even during the early hours of the 24 h, when the demands are lower compared to the peak ones, the DSO could not supply the demands in Areas 2 and 3, as seen in Figure 5b,c. By inspecting the results in Figure 4, it can be seen that L1 is near optimal to connect MGs. Intuitively, one might think that placing MGs near the biggest demand should reduce the system losses and enhance the yield, but the system structure may play a substantial role. Also, if bus 4 is removed, using the PowerWorld model in [55], a power outage takes place. Similarly, with bus 6, when bus 10 is removed, the majority of the lines in the network were overloaded.

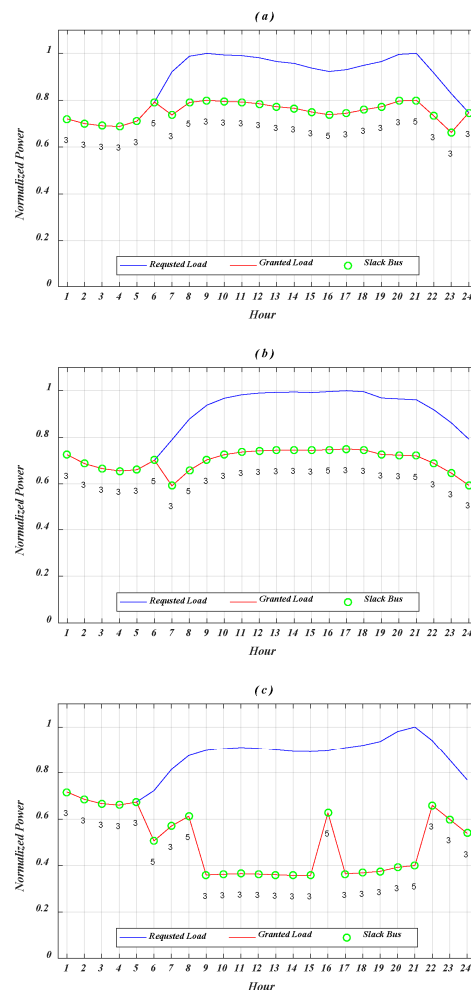

**Figure 4.** Normalized requested demand, and the power granted for 24 h when MGs located at L1 for: (a) Area 1; (b) Area 2 and (c) Area 3.

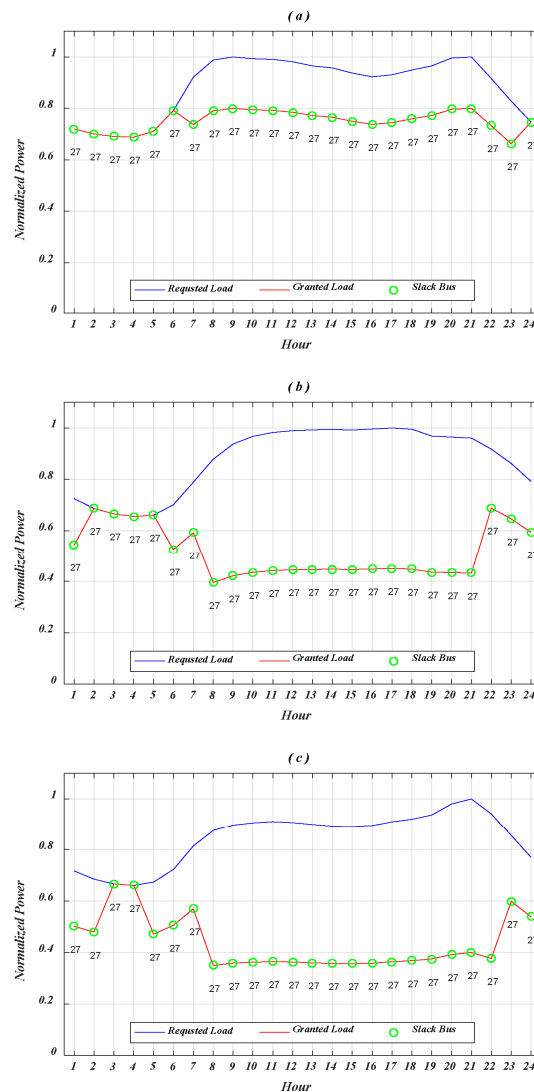

**Figure 5.** Normalized requested demand, and the power granted for 24 h when MGs located at L2 for: (a) Area 1; (b) Area 2; and (c) Area 3.

Figure 7a–c further show in details the yield factor through the 24 h in Area 1, 2 and 3 when the MGs were located at L1, L2, and L3 locations, respectively. Figure 7a shows that the yield factor of Area 1 among the three locations L1, L2, and L3 is comparable because Area 1 has the highest priority to be granted power. Also, the average yield factors of Area 1 for L1, L2, and L3 are 85.5%, 85.49%, and 87.31%. Figure 7b shows that for Area 2, the L2 MGs location has the lowest hourly yield factor and that of L3 is the highest. The average yield factors of Area 2 for L1, L2, and L3 are 82.6%, 61.57%, and 84.7%. Figure 7c demonstrates that L3 has the highest hourly yield factor for Area 3. The average yield factors of Area 3 for L1, L2, and L3 are 62.6%, 56%, and 79.3%. The overall average yield factor of the IEEE 30 bus system for L1, L2, and L3 MGs locations are 76.9%, 67.68%, and 83.76%. Figure 7d shows that L3 has the highest overall hourly yield factor in the IEEE 30 bus system. The overall average yield factors for the whole distribution network for locations L1, L2 and L3 are 76.89%, 67.68%, and 83.76%. These results show that with the MGs deployed at L3, which is suggested by the centrality analysis, more loads (~30 MW) could be supplied during a blackout within the permissible operational network limits. For further information about the detailed operation of the MGCC, the authors have other related work in [61–68].

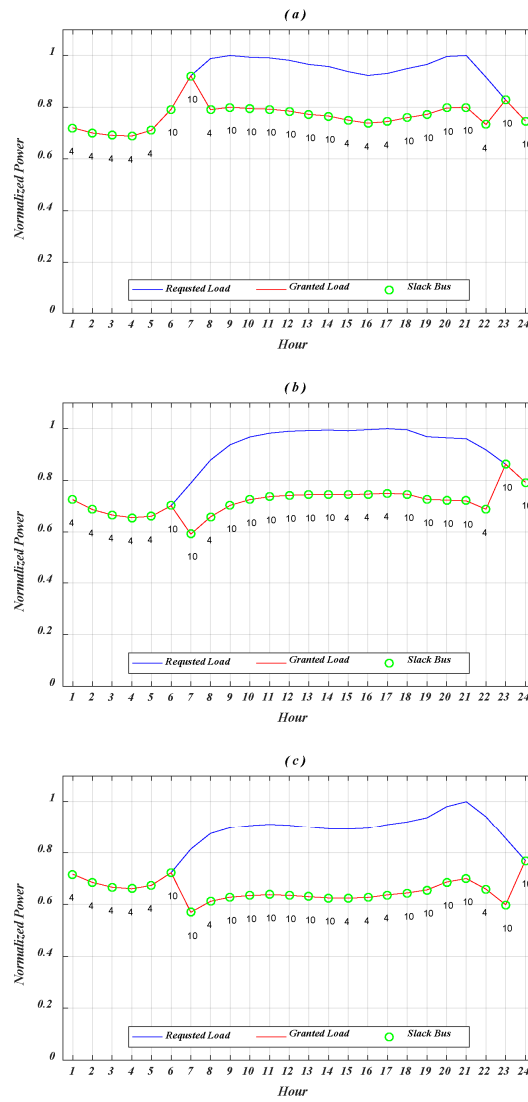

Figure 6. Normalized requested demand, and the power granted for 24 h when MGs located at L3 for: (a) Area 1; (b) Area 2; and (c) Area 3.

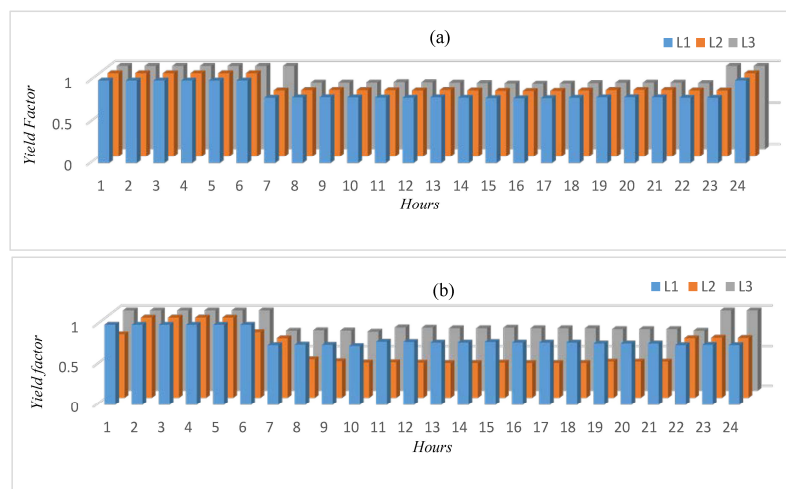
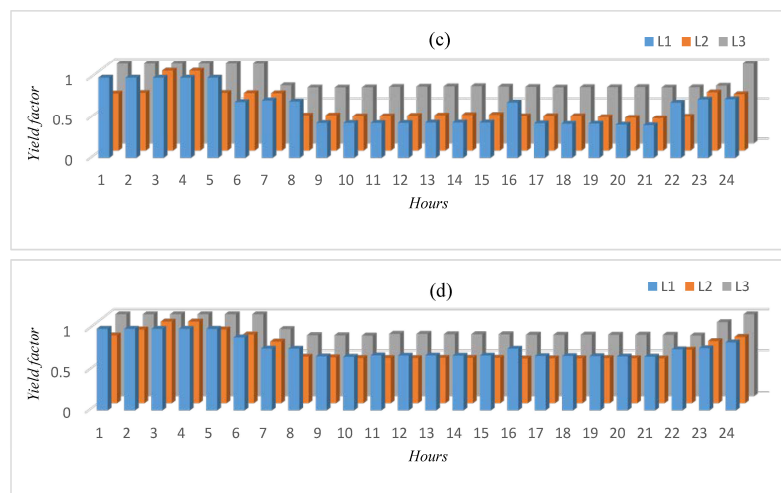

Figure 7. Cont.



**Figure 7.** The yield factors for various locations of the MGs (L1, L2, and L3) in: (a) Area 1; (b) Area 2; (c) Area 3; and (d) the IEEE 30 bus system.

## 6. Conclusions

This paper is a cohesive review of the application of complex network analysis in electrical power systems and sheds light on gaps that can be explored in future research. Moreover, this paper introduced a new methodology to inspect and analyze EDSs using CNA in a complex network framework to obtain pointers about the probable optimal locations/places to implement/connect MGs. The examination was executed utilizing CNA, the COM concept, and the controlled delivery grid (CDG) model. The IEEE 30 bus system was utilized to inspect the rationality and practicality of the suggested approach. It is worth mentioning that investigating all potential solutions to place/allocate an  $M$  no. of MGs in an  $N$  busses EDS needs enormous time and impractically large processing power. Complex network theory displays considerable advantages regarding finding the optimal location of MGs in an EDS to enhance its resilience.

**Author Contributions:** All the authors contributed to the work equally. M.S. proposed the idea/methodology and worked with Y.E. on it. They used MATLAB and PowerWorld software to conduct the analysis. They prepared the original writing/draft. A.M. is the mentor who offered guidance and proofread/edited the writing of the paper.

**Conflicts of Interest:** The authors declare no conflict of interest.

## References

- Shields, R. Cultural Topology: The Seven Bridges of Königsburg, 1736. *Theory Cult. Soc.* **2012**, *29*, 43–57. [CrossRef]
- Complex Systems Tutorial. Available online: <http://eldar.cz/cognition/complex/#Intuitive%20Definitions%20of%20Complexity.Steen,%20Maarten%20van.%20Graph%20Theory%20and%20Complex%20Networks:%20an%20Introduction.%20Maarten%20Van%20Steen,%202010> (accessed on 15 May 2018).
- Kim, J.; Wilhelm, T. What Is a Complex Graph? *Phys. A Stat. Mech. Appl.* **2008**, *387*, 2637–2652. [CrossRef]
- Nasiruzzaman, A.B.M.; Pota, H.R. Critical Node Identification of Smart Power System Using Complex Network Framework Based Centrality Approach. In Proceedings of the 2011 North American Power Symposium, Boston, MA, USA, 4–6 August 2011.
- Nasiruzzaman, A.B.M.; Pota, H.R. Transient Stability Assessment of Smart Power System Using Complex Networks Framework. In Proceedings of the 2011 IEEE Power and Energy Society General Meeting, Detroit, MI, USA, 24–28 July 2011.
- Gale, J. IEAGHG Information Paper: 2015-IP29; Emissions Performance Standards. Available online: [http://www.ieaghg.org/docs/General\\_Docs/Publications/Information\\_Papers/2015-IP29.pdf](http://www.ieaghg.org/docs/General_Docs/Publications/Information_Papers/2015-IP29.pdf) (accessed on 16 May 2018).

7. Digital Grid | ABB. Available online: <http://new.abb.com/grid/stronger-smarter-greener/digital-grid> (accessed on 16 May 2018).
8. Fact Sheet: President Obama to Announce Historic Carbon Pollution Standards for Power Plants. Available online: <https://obamawhitehouse.archives.gov/the-press-office/2015/08/03/fact-sheet-president-obama-announce-historic-carbon-pollution-standards> (accessed on 3 August 2015).
9. Modernizing Electric Power Delivery System. Available online: <https://www.energy.gov/sites/prod/files/2014/10/f18/ModernizingElectricPowerDeliverySystem.pdf> (accessed on 16 May 2018).
10. Grid Modernization and the Smart Grid | Department of Energy. Available online: <https://www.energy.gov/oe/activities/technology-development/grid-modernization-and-smart-grid> (accessed on 16 May 2018).
11. A Lucky Number: 13 Microgrids Proposed across New Jersey. Windpower Engineering & Development. Available online: <https://www.windpowerengineering.com/slider/lucky-number-13-microgrids-proposed-across-new-jersey/> (accessed on 16 May 2018).
12. Moradi, M.H.; Abedini, M. A Novel Method for Optimal DG Units Capacity and Location in Microgrids. *Int. J. Electr. Power Energy Syst.* **2016**, *75*, 236–244. [[CrossRef](#)]
13. Cagnano, A.; de Tuglie, E. A Decentralized Voltage Controller Involving PV Generators Based on Lyapunov Theory. *Renew. Energy* **2016**, *86*, 664–674. [[CrossRef](#)]
14. Ghiani, E.; Mocci, S.; Pilo, F. Optimal Reconfiguration of Distribution Networks According to the Microgrid Paradigm. In Proceedings of the 2005 International Conference on Future Power Systems, Amsterdam, The Netherlands, 16–18 November 2005.
15. Rojas-Cessa, R.; Sahasrabudhe, V.; Miglio, E.; Balineni, D.; Kurylo, J.; Grebel, H. Testbed Evaluations of a Controlled-Delivery Power Grid. In Proceedings of the 2014 IEEE International Conference on Smart Grid Communications (SmartGridComm), Venice, Italy, 3–6 November 2014.
16. Rojas-Cessa, R.; Xu, Y.; Grebel, H. Management of a Smart Grid with Controlled-Delivery of Discrete Power Levels. In Proceedings of the 2013 IEEE International Conference on Smart Grid Communications (SmartGridComm), Vancouver, BC, Canada, 21–24 October 2013.
17. Saleh, M.; Esa, Y.; Mohamed, A.A.; Grebel, H.; Rojas-Cessa, R. Energy Management Algorithm for Resilient Controlled Delivery Grids. In Proceedings of the 2017 IEEE Industry Applications Society Annual Meeting, Cincinnati, OH, USA, 1–5 October 2017.
18. Veolia. New Jersey Focuses on Resilience with State Microgrid Project. Text. Veolia North America. Available online: <https://www.veolianorthamerica.com/en/media/newsroom/new-jersey-focuses-resilience-state-microgrid-project> (accessed on 5 July 2017).
19. Wang, K.; Ouyang, Z.; Krishnan, R.; Shu, L.; He, L. A Game Theory-Based Energy Management System Using Price Elasticity for Smart Grids. *IEEE Trans. Ind. Inform.* **2015**, *11*, 1607–1616. [[CrossRef](#)]
20. Wang, Z.; Chen, B.; Wang, J.; Chen, C. Networked Microgrids for Self-Healing Power Systems. *IEEE Trans. Smart Grid* **2016**, *7*, 310–319. [[CrossRef](#)]
21. Albert, R.; Albert, I.; Nakarado, G.L. Structural Vulnerability of the North American Power Grid. *Phys. Rev. E* **2004**, *69*. [[CrossRef](#)] [[PubMed](#)]
22. Albert, R.; Jeong, H.; Barabási, A.-L. Error and Attack Tolerance of Complex Networks. *Nature* **2000**, *406*, 378–382. [[CrossRef](#)] [[PubMed](#)]
23. Cohen, R.; Erez, K.; ben-Avraham, D.; Havlin, S. Resilience of the Internet to Random Breakdowns. *Phys. Rev. Lett.* **2000**, *85*, 4626–4628. [[CrossRef](#)] [[PubMed](#)]
24. Callaway, D.S.; Newman, M.E.J.; Strogatz, S.H.; Watts, D.J. Network Robustness and Fragility: Percolation on Random Graphs. *Phys. Rev. Lett.* **2000**, *85*, 5468–5471. [[CrossRef](#)] [[PubMed](#)]
25. World Electric Power Plants Database: Global Market Data and Price Assessments—Platts. Available online: <https://www.platts.com/products/world-electric-power-plants-database> (accessed on 16 May 2018).
26. Goh, K.-I.; Kahng, B.; Kim, D. Universal Behavior of Load Distribution in Scale-Free Networks. *Phys. Rev. Lett.* **2001**, *87*. [[CrossRef](#)] [[PubMed](#)]
27. Newman, M.E.J. Scientific Collaboration Networks. II. Shortest Paths, Weighted Networks, and Centrality. *Phys. Rev. E* **2001**, *64*, 016132. [[CrossRef](#)] [[PubMed](#)]
28. Motter, A.E.; Matias, M.A.; Kurths, J.; Ott, E. Dynamics on Complex Networks and Applications. *Phys. D Nonlinear Phenom.* **2006**, *224*, vii–viii. [[CrossRef](#)]
29. Crucitti, P.; Latora, V.; Marchiori, M. A Topological Analysis of the Italian Electric Power Grid. *Phys. A Stat. Mech. Appl.* **2004**, *338*, 92–97. [[CrossRef](#)]

30. Martí, R.-C.; Valverde, S.; Solé, R.V. Topological Vulnerability of the European Power Grid under Errors and Attacks. *Int. J. Bifurc. Chaos* **2007**, *17*, 2465–2475. [[CrossRef](#)]
31. Solé, R.V.; Rosas-Casals, M.; Corominas-Murtra, B.; Valverde, S. Robustness of the European Power Grids under Intentional Attack. *Phys. Rev. E* **2008**, *77*. [[CrossRef](#)] [[PubMed](#)]
32. Coelho, E.P.R.; Thomazelli, J.C.; Paiva, M.H.M.; Segatto, M.E.V. A Complex Network Analysis of the Brazilian Power Test System. In Proceedings of the 2015 IEEE PES Innovative Smart Grid Technologies Latin America (ISGT LATAM), Montevideo, Uruguay, 5–7 October 2015.
33. Ding, M.; Han, P. Reliability Assessment to Large-Scale Power Grid Based on Small-World Topological Model. In Proceedings of the 2006 International Conference on Power System Technology, Chongqing, China, 22–26 October 2006.
34. Lu, Z.; Meng, Z.; Zhou, S. Cascading Failure Analysis of Bulk Power System Using Small-World Network Model. In Proceedings of the 2004 International Conference on Probabilistic Methods Applied to Power Systems, Ames, IA, USA, 12–16 September 2004.
35. Pagani, G.A.; Aiello, M. Towards Decentralization: A Topological Investigation of the Medium and Low Voltage Grids. *IEEE Trans. Smart Grid* **2011**, *2*, 538–547. [[CrossRef](#)]
36. Mei, S.; Zhang, X.; Cao, M. Complex Small-World Power Grids. In *Power Grid Complexity*; Springer: Berlin/Heidelberg, Germany, 2011.
37. Hines, P.; Blumsack, S. A Centrality Measure for Electrical Networks. In Proceedings of the 41st Annual Hawaii International Conference on System Sciences (HICSS 2008), Big Island, HI, USA, 7–10 January 2008.
38. Freeman, L.C. Centrality in Social Networks Conceptual Clarification. *Soc. Netw.* **1978**, *1*, 215–239. [[CrossRef](#)]
39. Girvan, M.; Newman, M.E.J. Community Structure in Social and Biological Networks. *Proc. Natl. Acad. Sci. USA* **2002**, *99*, 7821–7826. [[CrossRef](#)] [[PubMed](#)]
40. Newman, M.E.J. A Measure of Betweenness Centrality Based on Random Walks. *Soc. Netw.* **2005**, *27*, 39–54. [[CrossRef](#)]
41. Rajasingh, I.; Rajan, B.; Florence, I.D. Betweenness-Centrality of Grid Networks. In Proceedings of the 2009 International Conference on Computer Technology and Development, Kota Kinabalu, Malaysia, 13–15 November 2009.
42. Jawad, M.; Gou, B. Applications of Complex Network Theory on Power Grids. In Proceedings of the EIT 2013, IEEE International Conference on Electro-Information Technology, Lincoln, NE, USA, 14–17 May 2017.
43. Dobson, I.; Carreras, B.A.; Lynch, V.E.; Newman, D.E. An Initial Model for Complex Dynamics in Electric Power System Blackouts. In Proceedings of the 34th Annual Hawaii International Conference on System Sciences, Maui, HI, USA, 3–6 January 2001.
44. Carreras, B.A.; Lynch, V.E.; Sachtjen, M.L.; Dobson, I.; Newman, D.E. Modeling Blackout Dynamics in Power Transmission Networks with Simple Structure. In Proceedings of the 34th Annual Hawaii International Conference on System Sciences, Maui, HI, USA, 3–6 January 2001.
45. Carreras, B.A.; Lynch, V.E.; Dobson, I.; Newman, D.E. Critical Points and Transitions in an Electric Power Transmission Model for Cascading Failure Blackouts. *Chaos Interdiscip. J. Nonlinear Sci.* **2002**, *12*, 985–994. [[CrossRef](#)] [[PubMed](#)]
46. Carreras, B.A.; Lynch, V.E.; Newman, D.E.; Dobson, I. Blackout Mitigation Assessment in Power Transmission Systems. In Proceedings of the 36th Annual Hawaii International Conference on System Sciences, Big Island, HI, USA, 6–9 January 2003.
47. Carreras, B.A.; Newman, D.E.; Dobson, I.; Poole, A.B. Evidence for Self-Organized Criticality in a Time Series of Electric Power System Blackouts. *IEEE Trans. Circuits Syst. I Regul. Pap.* **2004**, *51*, 1733–1740. [[CrossRef](#)]
48. Dobson, I.; Carreras, B.A.; Lynch, V.E.; Newman, D.E. Complex Systems Analysis of Series of Blackouts: Cascading Failure, Critical Points, and Self-Organization. *Chaos* **2007**, *17*, 026103. [[CrossRef](#)] [[PubMed](#)]
49. Dwivedi, A.; Yu, X.; Sokolowski, P. Analyzing Power Network Vulnerability with Maximum Flow Based Centrality Approach. In Proceedings of the 2010 8th IEEE International Conference on Industrial Informatics, Osaka, Japan, 13–16 July 2010.
50. Dwivedi, A.; Yu, X. A Maximum-Flow-Based Complex Network Approach for Power System Vulnerability Analysis. *IEEE Trans. Ind. Inform.* **2013**, *9*, 81–88. [[CrossRef](#)]
51. Nasiruzzaman, A.B.M.; Pota, H.R.; Mahmud, M.A. Application of Centrality Measures of Complex Network Framework in Power Grid. In Proceedings of the IECON 2011—37th Annual Conference of the IEEE Industrial Electronics Society, Melbourne, Australia, 7–10 November 2011.

52. Chen, G.; Dong, Z.Y.; Hill, D.J.; Zhang, G.H. An Improved Model for Structural Vulnerability Analysis of Power Networks. *Phys. A Stat. Mech. Appl.* **2009**, *388*, 4259–4266. [[CrossRef](#)]
53. Arianos, S.; Bompard, E.; Carbone, A.; Xue, F. Power Grid Vulnerability: A Complex Network Approach. *Chaos* **2009**, *19*, 013119. [[CrossRef](#)] [[PubMed](#)]
54. Fang, X.; Yang, Q.; Yan, W. Modeling and Analysis of Cascading Failure in Directed Complex Networks. *Saf. Sci.* **2014**, *65*, 1–9. [[CrossRef](#)]
55. Pg\_tca30bus. Available online: [https://www2.ee.washington.edu/research/pstca/pf30/pg\\_tca30bus.htm](https://www2.ee.washington.edu/research/pstca/pf30/pg_tca30bus.htm) (accessed on 16 May 2018).
56. Ieee\_30\_bus\_technical\_note.Pdf. Available online: [https://hvdc.ca/uploads/knowledge\\_base/ieee\\_30\\_bus\\_technical\\_note.pdf?t=1460659229](https://hvdc.ca/uploads/knowledge_base/ieee_30_bus_technical_note.pdf?t=1460659229) (accessed on 16 May 2018).
57. Examples of Microgrids | Building Microgrid. Available online: <https://building-microgrid.lbl.gov/examples-microgrids> (accessed on 16 May 2018).
58. Freeman, L. A Set of Measures of Centrality Based on Betweenness. *Sociometry* **1977**, *40*, 35–41. [[CrossRef](#)]
59. Sabidussi, G. The Centrality Index of a Graph. *Psychometrika* **1966**, *31*, 581–603. [[CrossRef](#)] [[PubMed](#)]
60. Salkind, N. *Encyclopedia of Educational Psychology*; SAGE: Thousand Oaks, CA, USA, 2008; Volume 2. [[CrossRef](#)]
61. Saleh, M.; Esa, Y.; Mohamed, A.A. Communication Based Control for DC Microgrids. *IEEE Trans. Smart Grid* **2018**, *PP*, 1. [[CrossRef](#)]
62. Saleh, M.; Esa, Y.; Mohamed, A.A. Centralized Control for DC Microgrid Using Finite State Machine. In Proceedings of the IEEE Innovative Smart Grid Technologies Conference (ISGT), Washington, DC, USA, 23–26 April 2017.
63. Saleh, M.; Esa, Y.; Mohamed, A.A. Design and implementation of CCNY DC microgrid testbed. In Proceedings of the IEEE Industry Applications Society Annual Meeting, Portland, OR, USA, 2–6 October 2016.
64. Saleh, M.; Althaibani, A.; Esa, Y.; Mhandi, Y.; Mohamed, A.A. Impact of clustering microgrids on their stability and resilience during blackouts. In Proceedings of the International Conference on Smart Grid and Clean Energy Technologies (ICSGCE), Offenburg, Germany, 20–23 October 2015; pp. 195–200. [[CrossRef](#)]
65. Saleh, M.; Esa, Y.; Mohamed, A.A. Hardware Based Testing of Communication Based Control for DC Microgrid. In Proceedings of the International Conference on Renewable Energy Research and Applications (ICRERA), San Diego, CA, USA, 5–8 November 2017.
66. Saleh, M.; Esa, Y.; Onuorah, N.; Mohamed, A.A. Optimal Microgrids Placement in Electric Distribution Systems Using Complex Network Framework. In Proceedings of the International Conference on Renewable Energy Research and Applications (ICRERA), San Diego, CA, USA, 5–8 November 2017.
67. Saleh, M.; Esa, Y.; Mohamed, A.A. Impact of Communication Latency on the Bus Voltage of Centrally Controlled DC Microgrid during Islanding. *IEEE Trans. Sustain. Energy* **2017**, in press.
68. Saleh, M.; Esa, Y.; Mohamed, A.A. Effect of Wireless Communication Delay on Bus Voltage of Centralized Communication Based Control DC Microgrid. In Proceedings of the Energy Conversion Congress & Expo (ECCE) 2018 Conference, Portland, OR, USA, 23–27 September 2018.



© 2018 by the authors. Licensee MDPI, Basel, Switzerland. This article is an open access article distributed under the terms and conditions of the Creative Commons Attribution (CC BY) license (<http://creativecommons.org/licenses/by/4.0/>).