





## Article

# Load Frequency Control (LFC) Strategies in Renewable Energy-Based Hybrid Power Systems: A Review

Muhammad Majid Gulzar <sup>1</sup>, Muhammad Iqbal <sup>1</sup>, Sulman Shahzad <sup>2</sup>, Hafiz Abdul Muqet <sup>3</sup>,  
Muhammad Shahzad <sup>4</sup> and Muhammad Majid Hussain <sup>5,\*</sup>

<sup>1</sup> Department of Electrical Engineering, University of Central Punjab, Lahore 06375, Pakistan; majid.gulzar@ucp.edu.pk (M.M.G.); engrmiqbal786@gmail.com (M.I.)

<sup>2</sup> Department of Electrical Engineering, Islamia University of Bahawalpur, Bahawalpur 63100, Pakistan; salmanshahzad05@gmail.com

<sup>3</sup> Department of Electrical Engineering Technology, Punjab Tianjin University of Technology, Lahore 54770, Pakistan; abdul.muqet@ptut.edu.pk

<sup>4</sup> Department of Electrical Engineering and Technology, Muhammad Nawaz Sharif University of Engineering and Technology, Multan 60650, Pakistan; shahzadpansota@hotmail.com

<sup>5</sup> Department of Electrical and Electronic Engineering, University of South Wales, Pontypridd CF37 1DL, UK

\* Correspondence: muhammad.hussain@southwales.ac.uk

**Abstract:** The hybrid power system is a combination of renewable energy power plants and conventional energy power plants. This integration causes power quality issues including poor settling times and higher transient contents. The main issue of such interconnection is the frequency variations caused in the hybrid power system. Load Frequency Controller (LFC) design ensures the reliable and efficient operation of the power system. The main function of LFC is to maintain the system frequency within safe limits, hence keeping power at a specific range. An LFC should be supported with modern and intelligent control structures for providing the adequate power to the system. This paper presents a comprehensive review of several LFC structures in a diverse configuration of a power system. First of all, an overview of a renewable energy-based power system is provided with a need for the development of LFC. The basic operation was studied in single-area, multi-area and multi-stage power system configurations. Types of controllers developed on different techniques studied with an overview of different control techniques were utilized. The comparative analysis of various controllers and strategies was performed graphically. The future scope of work provided lists the potential areas for conducting further research. Finally, the paper concludes by emphasizing the need for better LFC design in complex power system environments.

**Keywords:** load frequency control; renewable energy systems; single-area power system; multi-area power system; optimization algorithms; multistage controllers; artificial neural networks; sliding mode controller



**Citation:** Gulzar, M.M.; Iqbal, M.; Shahzad, S.; Muqet, H.A.; Shahzad, M.; Hussain, M.M. Load Frequency Control (LFC) Strategies in Renewable Energy-Based Hybrid Power Systems: A Review. *Energies* **2022**, *15*, 3488. <https://doi.org/10.3390/en15103488>

Academic Editors: Hugo Morais and Rui Castro

Received: 9 March 2022

Accepted: 5 May 2022

Published: 10 May 2022

**Publisher's Note:** MDPI stays neutral with regard to jurisdictional claims in published maps and institutional affiliations.



**Copyright:** © 2022 by the authors. Licensee MDPI, Basel, Switzerland. This article is an open access article distributed under the terms and conditions of the Creative Commons Attribution (CC BY) license (<https://creativecommons.org/licenses/by/4.0/>).

## 1. Introduction

Power system stability is an important area of concern in modern interconnected power systems. It is termed as the capability of a power system to become stable after the removal of disturbances. While an unstable system loses its control by falling out of synchronism, this phenomenon may have a catastrophic impact on the smooth running of the power system. Stability concerns have become an integral part of the design of a reliable system; maintaining synchronism between different parts of the power system is a crucial task for power system engineers [1]. It is necessary to generate electric power in accordance with load side demand while considering the losses as well. A stable power system operates around a specific region, different external conditions may deviate the nominal frequency of the power system to an unstable region [2].

The frequency control in modern power systems is achieved using two control loops: one is primary, and the other is secondary [3]. The first one is responsible for preventing

the frequency transients provided using governor droop which can generate the steady state error [4]. The second method is known as automatic gain control or load frequency control which may regulate the system frequency at a stable level. In its early days, the load frequency control was obtained using conventional PID controllers, but further research developed intelligent controllers, fuzzy controllers, Sliding Mode Controllers and Tilt Integral Derivative controllers. A modern controller design based on sliding mode control and adaptive control pattern provides a better real-time control of the power system. Further research is being carried out in the areas of Brain Emotional Learning-Based Intelligent Controllers (BELBICs) and Support Vector Machine-based controllers to improve the performance.

This work focuses on the study of existing load frequency control strategies and suggestions for further improvements. The performance analysis was conducted for understanding the results of different simulated parameters. The shortcomings in different techniques were noted and the future road map was defined for better controller design. With the installation of renewable energy systems, the integration problem is getting complex. The improved power system design is only achieved with better power quality by implementing various load frequency control techniques.

### *1.1. Literature Review*

Modern power systems are going through a rapid transformation because of the integration of various renewable energy sources and the introduction of new systems such as autonomous grids, micro-grids, nano-grids and smart grid technologies [5]. Interconnecting the renewable energy sources, such as wind turbines, tidal turbines, geothermal plants, biomass plants, hydro power plants and photovoltaic cells, etc., makes the production of active power uncertain, as shown in Figure 1 [6]. A huge amount of research has been performed on the utilization of solar energy resources. Traditionally, the hydro energy systems are considered the best environmentally friendly source of energy, but its initial cost and time of construction is large, so solar energy is considered an easy alternative because of its lower construction cost and portability [7]. Hence, frequency deviations cause unreliable power system operation. These days, a power system is not vertically integrated but a deregulated entity requiring the unbundling into horizontal and vertical elements. In such circumstances, the analysis and development of improved frequency controller units becomes essential. A lot of research has been carried out for the development and improvements in the design of Load Frequency Controllers [8]. In [9], Krishan et al. worked on the automatic generation control of multi-area power plants with the help of a PID controller. In [10], robust multivariable predictive-based load frequency control was achieved considering the generation rate constraint. However, the designed controllers do not provide outstanding values of settling time, peak overshoot or peak undershoot values. The main task of a Load Frequency Controller is to adjust its parameters in accordance with its environment and reach a stable state quickly [11,12]. A lot of research has been carried out in an attempt to realize an ideal Load Frequency Controller, but most of the controllers have poor settling time issues, and recent research trends utilize the intelligent design technique in LFC design. In [13,14], an Artificial Neural Network-based LFC design targeted the deregulated electricity market. It is an example of an intelligent controller with a learning mechanism based upon surrounding events and incidents. The steady state response must be reached quickly with lower settling times and lower transient values [15,16].

In [17], the stochastic process with unknown input estimators was used for attack detection on LFC, hence exemplifying the cyber security mechanism in LFC applications. In [18], the optimal firefly algorithm was used for the load frequency control of deregulated environments.

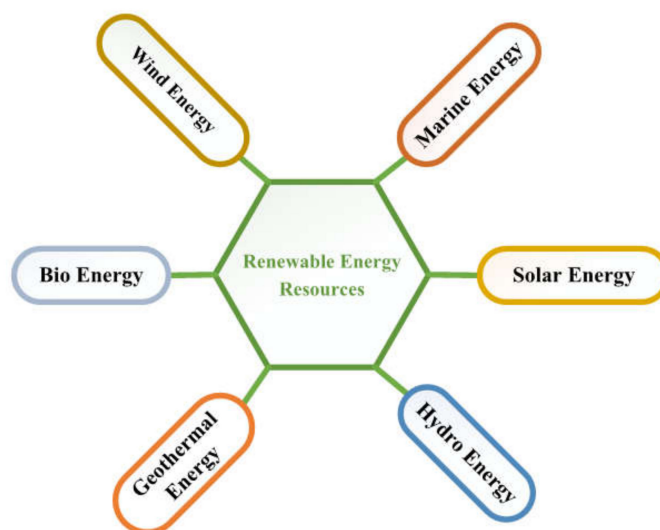

**Figure 1.** Renewable Energy Systems.

In [19], the artificial neuro fuzzy intelligent system was used for load frequency control in a power system integrated with SMES-TCPS combination. The proper LFC system design is robust and achieves the stability in a short amount of time [20,21]. In [22], an optimized fuzzy controller was used for the grid frequency control of a power system equipped with electric vehicles. The proper feedback system adjusts the input value in accordance with the system output [23]. In [24], the quasi-oppositional harmony search algorithm was used for the load frequency control of an autonomous hybrid power system. The variations in frequency must be diminished in a quick way to design a stable system [25]. In [26], the hybrid DE-PS algorithm was used for the load frequency control of a hybrid system with UPFC and RFB. Load frequency control evolved with the development of various techniques in different areas of power systems. With the addition of more areas, the power system became complex, inviting the need for the development of better control strategies.

In the past, power generation, transmission and distribution in multi-area interconnected power systems was achieved using a single entity known as a vertically unified utility [27]. In such arrangements, the consumer gets power at a specific rate. The lack of competition decreases the efficiency of the power system, this issue can be tackled by restricting the structure of the overall system. The restructuring of the power system and introduction of different load frequency techniques improved the reliability of the system. The advancement in renewable energy systems and integration with existing power systems introduced the concept of hybrid power systems, which is intended to reduce the dependence on conventional energy sources.

In this article, it is observed that most of the researchers worked to achieve load frequency control in conventional interconnected power systems. Due to advancements in the area of renewable energy sources, people are switching towards more environmentally friendly and cheap energy resources such as solar, wind and hydel [28]. The integration of these new technologies with existing systems based on conventional fossil fueled power plants creates some integration issues in which the load frequency control is most pronounced [29]. The variation in load demand causes a deviation in frequency which is very dangerous and may disrupt any interconnected area. Frequency above the specified limits may cause a blackout of the power system. The major cause is the high penetration of non-conventional distributed energy resources producing higher system inertia [30]. The modern control procedures require the delivery of predictable power with improved frequency regulation.

### 1.2. Research Motivation

The title of this paper revolves around developing an understanding of different LFC control strategies in renewable energy-based hybrid power systems. Literature review presents a lot of LFC control strategies for interconnected hybrid power systems. These techniques target the optimal control of hybrid power systems for an improved power system response. Most of the researchers addressed the traditional interconnected power systems which are shrinking with the passage of time [31]. These days, the focus of the world is towards the deployment of renewable energy sources as they are environmentally friendly and have a lower operational cost. The interconnection of renewable energy sources with a traditional power system creates power quality issues. It is not always easy to maintain the load frequency control while delivering the required amount of power. The inertia of the power system and intermittent generation causes frequency deterioration issues [32]. A higher number of interconnected systems may cause issues such as frequency deviation, voltage instability and poor power quality. Some innovative work and novel ideas are necessary to address these issues and enhance the level of integration of renewable energy sources in existing power system networks. Conducting a review of past research, it is observed that researchers preferred to focus on conventional LFC development but the continuous deployment of renewable energy resources in existing power systems has encouraged research in load frequency control [33]. This is the motivation behind the present review which details the integration of renewable energy sources with existing power system networks.

### 1.3. Contribution and Novelty

The contribution and novelty of the present work is given below:

- (a) A comprehensive review of load frequency control for hybrid power systems.
- (b) Review of different types of renewable energy systems tied with conventional power systems and the resulting load frequency control.
- (c) Challenges and opportunities in load frequency control of hybrid power systems.
- (d) Graphical analysis of undershoot, overshoot and settling time parameters performed for major load frequency schemes.
- (e) Analysis of existing LFC techniques and its shortcomings. Suggestion about the future work for better LFC control.

## 2. Review on Load Frequency Control Considering Renewable Energy Sources

There are several power system configurations in renewable energy systems, but in this research, these are classified as single-area power systems and multi-area power systems. The former is an isolated power system, while the latter is usually a tied power system. The environmental non-linearity disturbs the normal operation of the power system, the interconnection of renewable energy systems develops transients and frequency deviations [34]. The introduction of modern power generation, transmission and distribution techniques makes the power system operation complex. The power quality tackling in complex power system research and development is being carried out in the field of Load Frequency Controllers. Various control strategies and optimization algorithms have been suggested for the improvement of power quality and response of the system to the abnormalities [35]. The employment of LFC in various areas along with optimization techniques is shown in Figure 2. Different algorithms are used for LFC optimization in order to improve the transient response and settling time.

Different control methods in LFC development include classical control, optimal control, adaptive control, variable structure control and robust control. The restructuring of rules and regulations imposed by the government introduced deregulations in the power system. These days, electricity is traded as a commodity, creating the issue of transmission congestion. The multi-area deregulated systems create the issues of transmission congestion focusing on the need of sophisticated LFC structures. With more people installing renewable energy systems at home, the concept of distributed generation is getting more attention. The power

generated at different isolated locations creates power quality issues which can be addressed using a better-designed LFC. From a configuration point of view, the power system can be categorized as a single-area power system and multi-area power system.

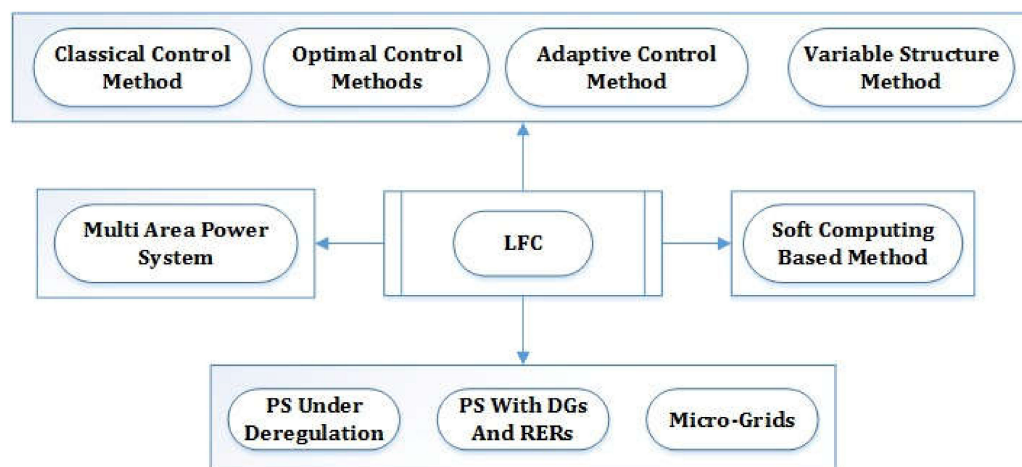

**Figure 2.** LFC in Different Environments.

Different soft computing approaches are used for the intelligent tuning of LFC controllers in modern power systems [36]. For islanded microgrids, a FOFPID controller has been developed using the multi-objective extremal optimization method [37]. The Flower Pollination algorithm was used for the optimization of the PI-PD cascade controller in regulating the AGC in multi-area power systems [38]. The iterative proportional-integral-derivative  $H_\infty$  controller was developed to iteratively stabilize the power system transients in a hybrid environment [39]. The biogeography-based optimized three-degrees-of-freedom integral-derivative controller has been developed for the load frequency control of a hydrothermal system under a deregulated environment [40]. The modified multi-objective genetic algorithm was used for the development of a framework for economic load frequency control in hybrid power systems [41]. In this case, the power system quality is maintained from an economical point of view and to meet the customer requirements.

The hybrid differential evolution particle swarm optimization was used for the development of a fuzzy proportional-integral derivative controller [42]. This controller targets the automatic generation control of interconnected power systems, hence the transients produced in one system avoid reaching the other system. The particle swarm optimization and ANFIS techniques combined together for the tuning of a PID controller [43]. The settling time and peak overshoot parameters are significantly controlled. The particle swarm optimization was used for fractional order control and simulation of wind-biomass isolated hybrid power systems [44]. The developed system maintains the power quality and delivers the required amount of power in a specified amount of time. The interconnection of two or more systems creates the issue of non-linearity, hence the cuckoo search algorithm-based Load Frequency Controller design for nonlinear interconnected power systems [45]. The steady state is reached in minimal time, and the transient response of the system improves as well. To further improve the load frequency control, a modified form of the cuckoo search algorithm known as the non-dominated cuckoo search algorithm was applied for the tuning of LFC [46]. The non-dominated cuckoo search algorithm-optimized controller improves the frequency regulation characteristics of the wind thermal power system. To target the frequency response of hybrid power systems, an effective hybrid harmony search and cuckoo optimization algorithm-based fuzzy PID controller used for load frequency control [47].

The nonlinearities always posed operational issues in LFC development; hence, the bacterial foraging optimization algorithm-based design of PID controller has been implemented for two-area load frequency control [48]. The BFOA algorithm is further combined



with the particle swarm optimization algorithm for multi-objective load frequency control in hybrid power systems [49]. For the intelligent tuning of LFC, neural-network-based integral sliding mode control was developed for nonlinear power systems with wind turbines [50]. The neuro-fuzzy hybrid intelligent PI control approach was adopted in four-area load frequency control of an interconnected power system [51]. Deep learning techniques was used for data forgery detection in automatic generation control [52]. Predictive control was used for real-time frequency regulation and rotational inertia provision in power systems [53]. To further improve the intelligent control techniques, supervisory predictive control of power system was developed [54]. The model predictive control was developed for power system frequency control taking into account imbalance uncertainty [55]. It provided better state estimations and resulted in more sophisticated control of power system networks.

The distributed model predictive control was developed for load frequency control with dynamic fuzzy valve position modeling for a hydrothermal power system [56,57]. It improved the overall transient and steady state response of the power system. The hybrid differential evolution-grey wolf optimization algorithm was applied to the automatic generation control of a multi-source interconnected power system using an optimal fuzzy PID controller. The cascaded design of a PD-fuzzy-PID controller was optimized using fuzzy logic techniques [58].

### 2.1. Single-Area Power System

A single-area power system contains only one renewable energy source which can be wind, solar, biomass, hydel or tidal. It is a simple system where power generation and utilization are easy. A wind turbine-based single-area power system is shown in Figure 3. Here, the feedback loop contains a controller which tracks the output signal and adjusts the parameters of the system to maintain output power quality.

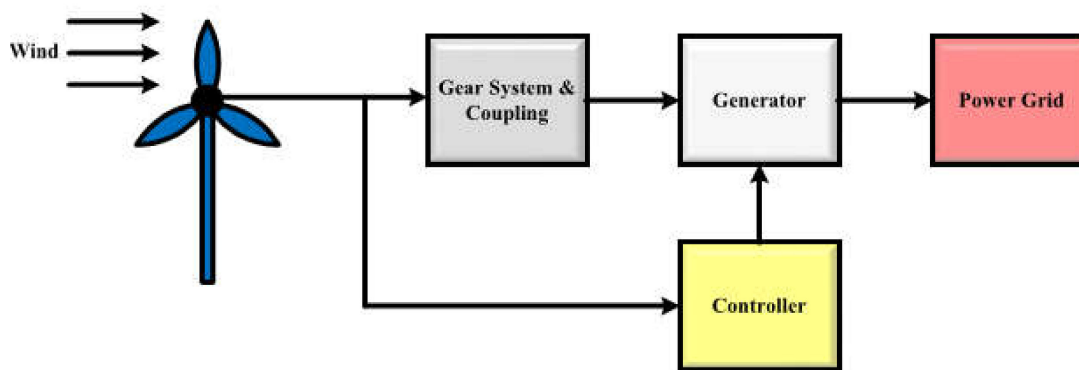

**Figure 3.** Wind Turbine-Based Single-Area Power System.

LFC's design for a single-area power system has been improved with the passage of time to lower the settling time, overshoot and undershoot in the output signal. In modern power systems consisting of a number of generation sources, the disturbance imposes on the power system variables developing errors in system operation. The development of a disturbance rejection procedure is the need of time. In [59], the Microgrid System presented by Qi et al. uses an improved linear active disturbance rejection control algorithm (ILADRC) for tuning the PID controller. The results suggested a superior performance than LADRC, Fuzzy PI and conventional PI controllers. The power system is tested under different test conditions and each scenario showed a remarkable improvement in power system operation.

In [60], worked on the tuning of PID controllers using the Mine Blast Algorithm (MBA) showing remarkable improvements in settling times and peak overshoot values. Integrating a superconducting magnetic energy storage system enhances the convergence of signals in a power system, as done in [61] by Wichan et al. Here, the bee optimization algorithm

was used for system optimization providing superior performance to a conventional PID and SF-FLPID. The scaling factor fuzzy logic PID provides better control on the gains of a conventional controller.

## 2.2. Multi-Area Power System

Modern power systems are becoming flexible, and renewable energy sources such as wind and solar can be integrated with conventional power plants. The load frequency control is a complicated task in multi-area power systems because of the increased instability due to the interconnection of different generation sources. LFC design for a multi-area power system is based on the amount of frequency deviation in each area of control. The tie line power deviation is a serious issue in interconnected systems; it can generate transients and instability of the power system. An abrupt variation in load and power generated by renewable energy sources can cause huge instability in output power.

The tie line power exchange between various areas is shown in Figure 4, each of the areas consist of conventional units with distributed generation and connected with various sub-systems. The interconnection of different areas creates problems such as transients and harmonics. The power imbalances create the issue of power flow on the interconnected lines; hence, the frequency control involves power flow measurement on the interconnected lines. The frequency control characterizes the whole power system, and its control is crucial for reliable operation. To maintain the power system frequency at a fixed level, the total amount of active power generation must be equal to the active power consumption at any instant of time.

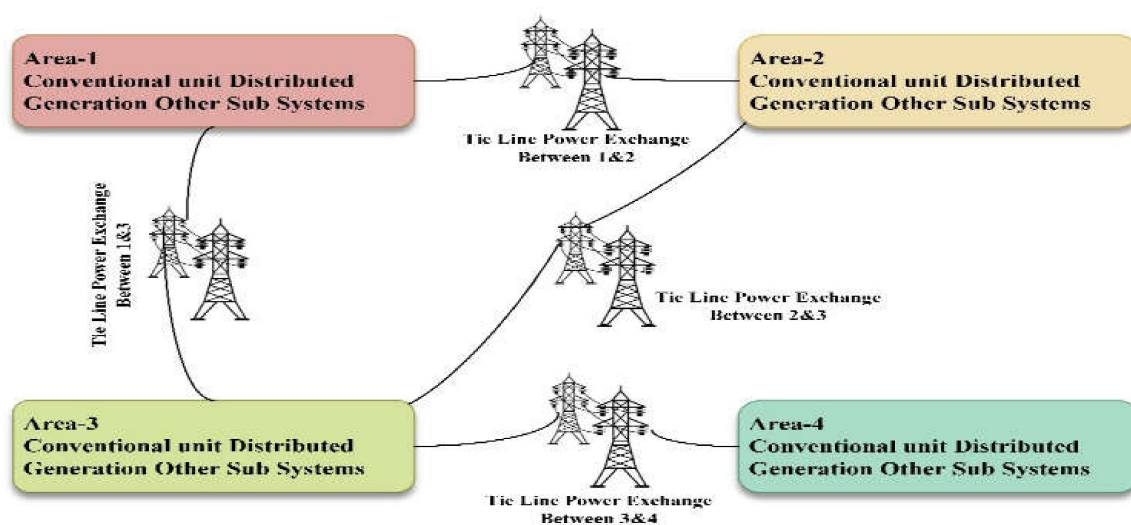

Figure 4. Power Exchange between Different Areas.

Figure 5 shows the Tie Line Interconnection of various GENCOs; here, the system is divided into various areas. Each area contains generation companies (GENCOs) and distribution companies (DISCOs), while the tie lines are used for interconnection purposes. Making such a configuration in terms of the number of areas improves the manageability of the power system. In each area, the power flows between the GENCO and DISCO, while tie lines allow the power flow in-between the areas. There is a bidirectional power flow in-between the areas, GENCOs and DISCOs.

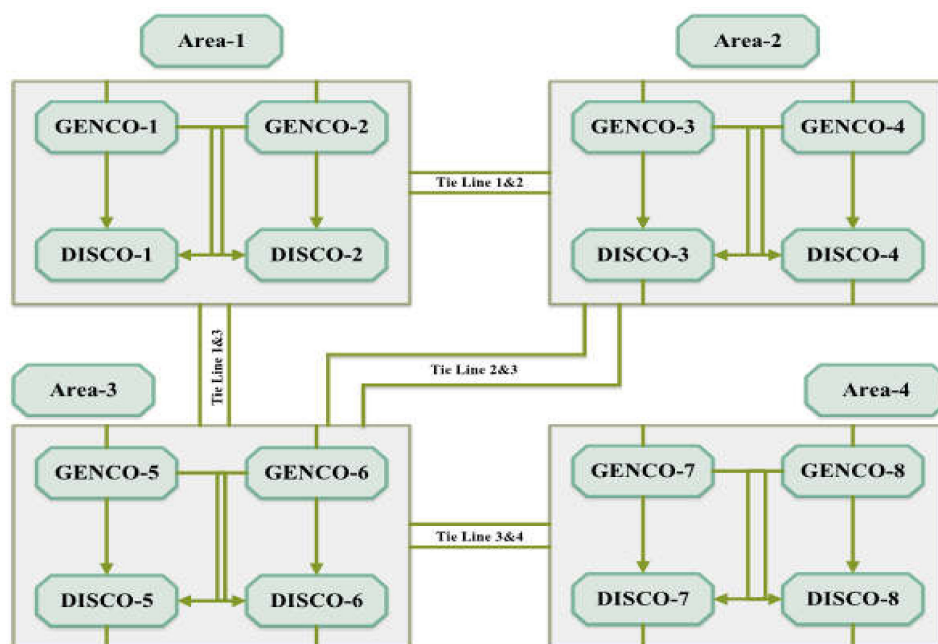

Figure 5. Tie Line Interconnection of GENCO.

### 2.3. Multi-Stage Controllers

Single-stage controllers are easy to operate and inexpensive; different techniques have been developed for the optimization of settling time, overshoot and undershoot values. Further improvements in settling times and overshoot values have been achieved using cascading controllers. Although it makes the system a little bit complex, it provides results not achievable using simple controllers. In [62], worked on a two-stage FPIDN-FOI controller optimized with the Imperialist Competitive (ICA) Algorithm; the settling time, overshoots and undershoots improved a lot compared to HFA-, PS- and GWO-optimized PID. In [63], used two-stage adaptive Fuzzy PI controllers optimized with the particle swarm optimization algorithm (PSO) and grey wolf optimization algorithm (GWO). The results show a superior performance in settling time, peak overshoot and peak undershoot of a two-stage controller. In [64], Gulzar et al. worked to develop an adaptive fuzzy-based optimized proportional-integral controller to mitigate the frequency oscillation of a multi-area photovoltaic thermal system. The results of this work are exceptional as the settling time reduced significantly.

A similar approach adopted by [65] using an invasive weed optimization algorithm (IWO) achieved remarkable success in lowering the settling time value with a cascaded approach. To adjust the controller parameters, continuously retrieving the system performance adaptive control was developed [66]. The two-stage topology combined with the adaptive control system provides better control of the power system on a continuous basis.

### 3. Types of Controllers on the Basis of Different Control Techniques

Different controllers have been developed with the passage of time as research has been conducted to improve one of the deficiencies in the existing controllers. The evolution of intelligent computing techniques led to the development of Artificial Neural Network (ANN) controllers, which eased the decision-making process in control structures. The development of fuzzy logic yielded multi-level control schemes between two extreme values; these controllers improved the level of control and accuracy of output signals.

Non-linearity is a generic issue in every control system; hence, non-linear control systems have been developed to take care of abnormalities. The work in probability improved the statistical analysis and techniques for the development of improved control systems. Addressing different deficiencies in power systems led to the development of various algorithms such as Genetic and Differential Evolution, while the swarm intelli-



gence integrated the concepts of colonial intelligence for the development of ant colony optimization and particle swarm optimization. Different soft computing methods are shown in Figure 6; the successive developments in different areas lead to improved control algorithms. The metaheuristic approaches lead to the development of swarm intelligence and evolutionary strategies. The genetic algorithm and differential evolution are some of the basic evolutionary techniques, while ant colony optimization and particle swarm optimization are sub-areas of swarm intelligence.

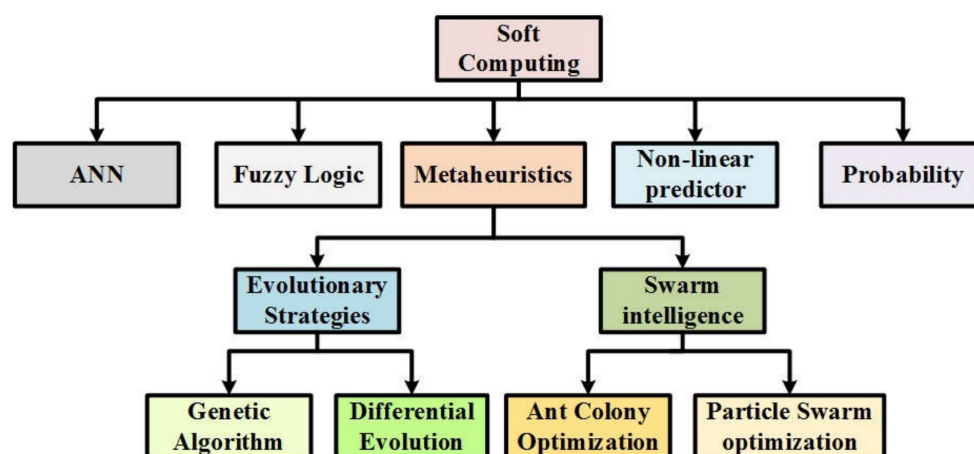

Figure 6. Soft Computing Methods.

### 3.1. PID-Based Controllers

The conventional PID controllers are simple and user-friendly devices with a low initial cost. The main issue with these devices is the poor dynamic response, low accuracy and high settling time. In [67], a hybrid bacterial foraging particle swarm optimization (BFPSO) technique was adopted for the effective tuning of PID controller. The dynamic response of the designed controller is far better than the PID controller tuned with PSO, BFOA. The system has very fast and consistent convergence values. The performance indices of a BFPSO-tuned PID compared with an advance algorithm CBPSO. The BFPSO has much better settling times, overshoot and undershoot values. In [68], Guha et al. adopted a metaheuristic optimization approach Symbiotic Optimization Search (SOS) for the tuning of PID. The dynamic stability increase was confirmed by time domain analysis; the sensitivity analysis confirmed the robustness of the controller for different loading conditions and uncertainties. It can be seen clearly that SOS algorithms yield better performance of PID controllers compared to PSO tuning. In [69], the harmony search (HS) algorithm was employed for the tuning of a PIDA controller to achieve a better load frequency control in wind energy control systems. In [70], the Backtracking Search Algorithm (BSA) was employed for load frequency control in a multi-area interconnected power system. In [71], JAYA algorithm tuning performed for PID controller and employed in automatic generation control of two-area ST-Thermal power system. In [72], the Gravitational Search Algorithm-based PID controller was developed for two-area multi-source power system load frequency control. This technique provided lower settling time while optimizing undershoot and overshoot values. In [73], the particle swarm optimization technique used in two-area interconnected automatic generation control including renewable energy sources. In [74], coordinated control of conventional power sources and PHEVs was achieved using the JAYA algorithm optimized PID controller for frequency control of a renewable penetrated power system. In [75], active power management of a virtual power plant under penetration of a central receiver solar-thermal-wind system was performed using the butterfly optimization technique. In [76], the grey wolf optimization (GWO) algorithm was used for the multi-area load frequency control of a hydrothermal wind power plant. Table 1 lists the performance indices for said techniques.

**Table 1.** Performance Indices of PID Controller in an Interconnected Power System.

Performance Indices	[67] HBFPSO-PID	[68] SOS PID	[69] HS-PIDA	[70] BSA-PID	[71] JAYA-PID	[72] GSA-PID	[73] PSO-PID	[74] JAYA-PID	[75] BOA-PID	[76] GWO-PID
$\Delta f_1$ ST (S)	7.7337	1.39	24	8.68	8.53	1.6	$18.23 \times 10^{-3}$	18	70.3	35.2
$\Delta f_1$ US (Hz)	0.0115	11	$0.95 \times 10^{-4}$	-	0.0202	0.00269	$27.48 \times 10^{-3}$	49.98	0.0075	-
$\Delta f_1$ OS (Hz)	-	11.7	-	0.002	0.0028	-	$12.49 \times 10^{-3}$	-	0.0142	10.7
$\Delta f_2$ ST (s)	7.328	2.52	12.5	25.8	7.53	3.3	$16.91 \times 10^{-3}$	15	72.02	44.2
$\Delta f_2$ US (Hz)	0.0086	0.655	$-6.3 \times 10^{-4}$	-	0.0159	0.0006	$-34.8 \times 10^{-3}$	49.97	0.0056	-
$\Delta f_2$ OS (Hz)	-	6.8	$5.00 \times 10^{-5}$	0.0021	$3.42 \times 10^{-5}$	-	$10.45 \times 10^{-3}$	-	0.0121	0.011
$\Delta P_{tie}$ ST (s)	7.4793	2.46	24	22.6	22.9	3.8	$34.4 \times 10^{-3}$	11	72.6	41.8
$\Delta P_{tie}$ US (Hz)	0.0024	0.228	$15.8 \times 10^{-4}$	-	0.0125	0.00023	$-8.9 \times 10^{-3}$	4	0.0023	-
$\Delta P_{tie}$ OS (Hz)	-	2.4	$15.8 \times 10^{-4}$	$1.70 \times 10^{-6}$	0.00167	-	$0.66 \times 10^{-3}$	-	0.0041	0.025

The dynamics behavior of frequency deviation for interconnected renewable energy-based power systems is plotted in Figures 7 and 8. The PSO-PID in [75] gives the lowest settling time of 0.01823, while undershoot and overshoot values are optimized as well.

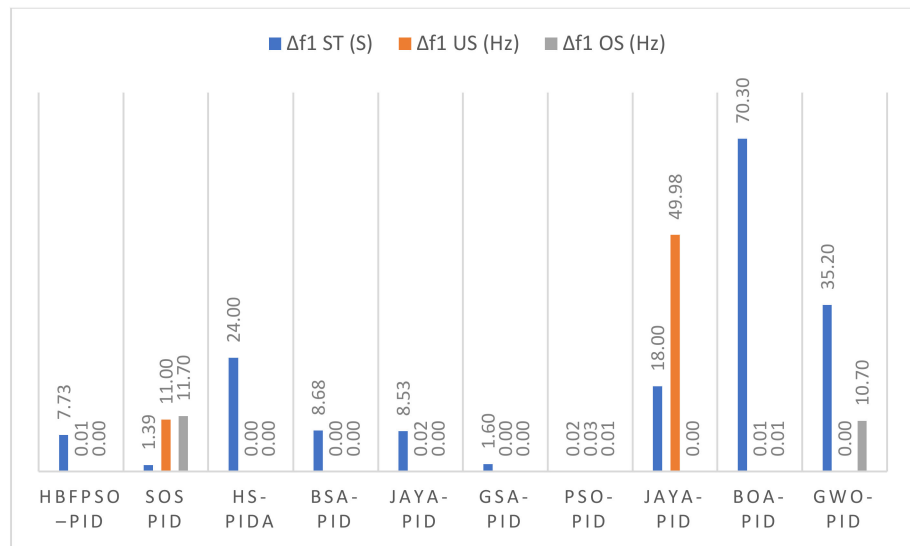

**Figure 7.** Frequency Deviation for Interconnected Systems.

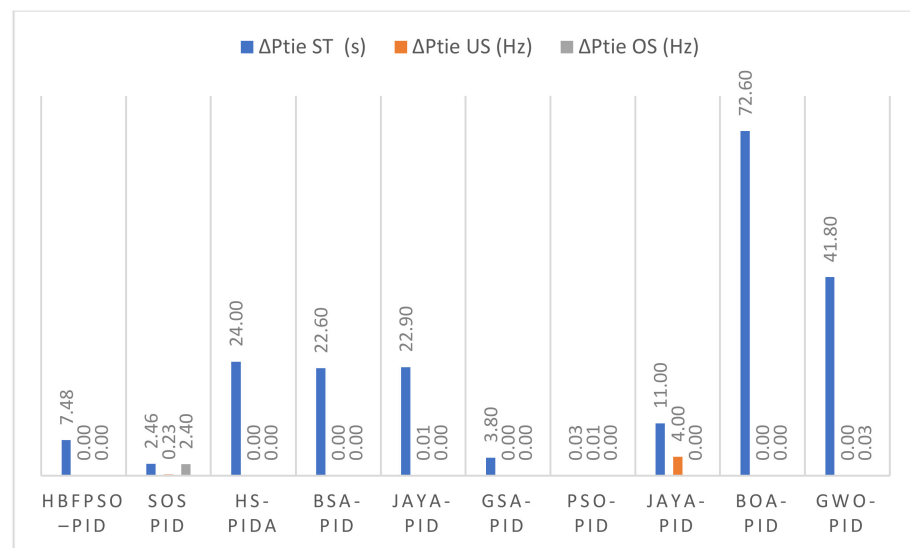

**Figure 8.** Frequency Deviation for Interconnected Systems.

Figure 7 shows the dynamics behavior of frequency deviation for interconnected renewable energy-based power systems. It is clear that the [75] BOA-PID has the worst settling time, while [73] PSO-PID has the best settling time value. The [68] SOS-PID is the second-best choice in terms of settling time.

In [77], a novel modified robust load frequency control was developed for massless inertia photovoltaics penetrations via the hybrid PSO-WOA approach. In [78], ICA-PID was developed for the primary frequency regulation of a micro-grid by de-loaded tidal turbines. In [79], the Mine Blast Algorithm tuning was performed in a PID controller for performance enhancement of the micro-grid system with SMES storage system. In [80], the Mine Blast Algorithm was used for the tuning of PID employed in parabolic through a solar-thermal-wind-diesel-isolated hybrid power system. In [81], a novel multistage PID approach was adopted for frequency dynamics control in an islanded micro-grid. In [82], frequency regulation was used in an AC micro-grid with and without an electric vehicle using a multiverse-optimized fractional order PID controller. The settling time and peak undershoot values are well-optimized serving as performance indices of system robustness against load disturbances and parameter variations. In [83], BW-PID was used for tidal supplementary CONTROL schemes-based load frequency regulation of a fully sustainable marine micro-grid. In [84], quasi-oppositional harmony search algorithm-based optimal dynamic load frequency control of a hybrid tidal-diesel power generation system was performed. In [85], an Optimal Power Flow Controller was developed for grid-connected micro-grids using the grasshopper optimization algorithm. To tackle the performance issues in an autonomous hybrid power system, the tuning of a PID controller was performed using the flower pollination algorithm (FPA) [86]. It is clear that an FPA-tuned PID controller provides better values for US and OS parameters. The designed controller performs better than the PI controller in terms of peak transient deviation and settling time. The optimum gains of the controller remain unchanged for various load conditions, making it a good choice under a dynamic loading operation. In [87], HHO-PID was developed for multi-area multi-source load frequency control of interrelated power system.

The performance indices of a PID controller in an isolated power system are listed in Table 2. The settling time is reduced from the PSO-WOA PID to HHO-PID controller. The transient stability depends on the amount of settling time required for the signal to reach a steady state.

**Table 2.** Performance Indices of PID Controller in an Isolated Power System.

Performance Indices	[77] PSO-WOA PID	[78] ICA-PID	[79] MBA-PID	[80] MBA-PID	[81] MS-PID	[82] MVO-PID	[83] BW PID	[84] QOSHA PID	[85] GOA-PID	[86] PID-FPA	[87] HHO-PID
$\Delta f$ ST (S)	16.02	11.08	8.5455	4.415	4	2.6605	1.75	0.832	0.057	0.00043	-
$\Delta f$ US (Hz)	0.082	0.28	0.00094	0.0065	0.005	0.0216	0.01	-	-	0.0009	1.98
$\Delta f$ OS (Hz)	0.024	-	0.00451	0.0227	-	-	0.0025	1.676	7.16308	-	2.551

In Figure 9, it is clear that PID-FPA has the lowest settling time value of 0.000439 s. On the other hand, PSO-WOA has the worst settling time of 16.02 s. The PID controllers have the issue of poor settling times, and research is being conducted to mitigate transients in a minimal amount of time.

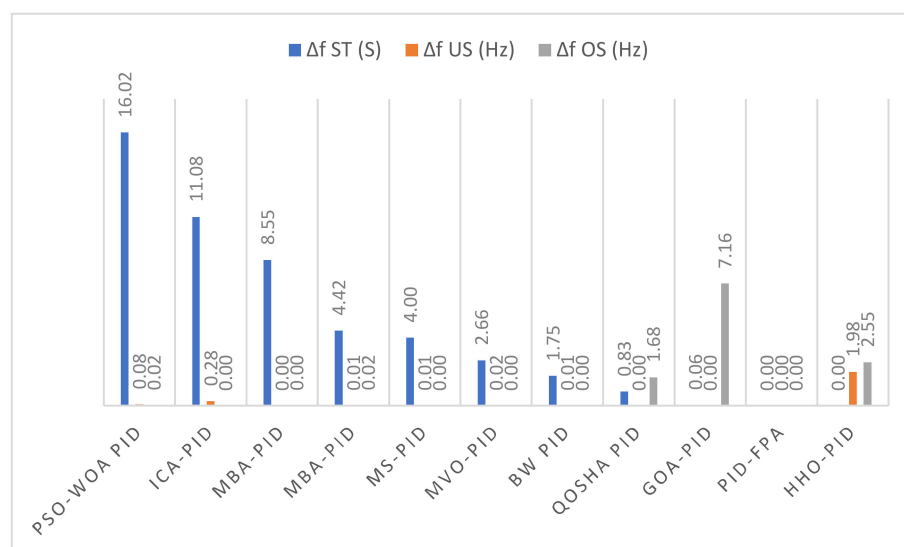

**Figure 9.** Frequency Deviation for Isolated Systems.

### 3.2. Fuzzy Logic-Based Controllers

Fuzzy logic controllers were designed to work as LFCs and optimized using various algorithms. In [88], the design and analysis of a BFOA-optimized PID controller was performed with a derivative filter for frequency regulation in a distributed generation system. In [89], Kumar et al. added a derivative filter with a fuzzy PID to generate the desired quality output signals. The controller optimization was performed using the Multiverse Optimization (MVO) approach. In [90], load frequency control of a multi-source multi-area nonlinear power system was performed with a DE-PSO-optimized fuzzy PID controller in coordination with SSSC and RFB. In [91], a simplified grey wolf optimization technique was used for adaptive fuzzy PID controller design for frequency regulation of a distributed power generation system. In [92], Debnath et al. worked on the development of a fuzzy PID and optimized it using differential evolution grey-wolf optimization (DE-GWO). The settling time was found to be better compared to a DE-PID and fuzzy PID. The multistage approach adopted in the case of PID controllers yielded better simulation results compared to a conventional single-stage controller. The settling times are reduced sharply, while the overshoot and undershoot values are optimized. In [93], the hybrid differential evolution-grey wolf optimization algorithm was applied to automatic generation control of a multi-source interconnected power system using optimal fuzzy PID controller. In [94], a novel intrusion mitigation unit was developed for interconnected power systems in frequency regulation to enhance cybersecurity. In [95], Debnath et al. developed a PD-fuzzy PID controller optimized with the GWO and TLBO algorithms which showed clearly better results than a PID or fuzzy PID controller. Combining a fuzzy PID controller with a derivative filter can lower the number of overshoots in the output signal. The PD-fuzzy PID have much better performance compared to the simple PID controller. Adding the filter in the control structure helps to lower down the ripple contents in the output signal. The results showed improvements in overshoots and undershoots compared to conventional I, PI and PIDF controllers. The fuzzy PID controller performs in a much better way under loaded conditions. The work of [96] improved the automatic generation control of two-area electric power systems performed via a new fuzzy-aided optimal PIDN-FOI controller.

Table 3 lists the transient stability parameters for an interconnected power system. Here, it is clear that the settling time improves from [88] PIDF to [96] FPIDN-FOI. The latter has the lowest settling time at 0.34 s.

**Table 3.** Performance Indices of Fuzzy Controller in an Interconnected Power System.

Performance Indices	[88] PIDF	[89] FPIDF	[90] FPID	[91] AFPID	[92] FPIDF	[93] FPID	[94] FPID	[95] PD-FPID	[96] FPIDN FOI
$\Delta f_1$ ST (S)	13.73	5.6874	2.59	1.18	1.099	0.7294	0.7	0.6853	0.34
$\Delta f_1$ US (Hz)	0.0098	0	$5.20 \times 10^{-3}$	$9.70 \times 10^{-3}$	0.19	0.1296	0	0.2391	0
$\Delta f_1$ OS (Hz)	0.0006	0.0232	$5.66 \times 10^{-4}$	$0.00 \times 10^0$	1.89	0.52	0.0009	0.54	0.0036
$\Delta f_2$ ST (s)	11.96	6.4872	3.29	$2.17 \times 10^0$	2.299	1.5128	0.2	0.9173	0.57
$\Delta f_2$ US (Hz)	0.0221	0	$5.10 \times 10^{-3}$	$2.40 \times 10^{-3}$	0.111	0.056	0	0.0332	0
$\Delta f_2$ OS (Hz)	0.0032	0.0132	$7.26 \times 10^{-4}$	$0.00 \times 10^0$	0.49	1	0.00001	0.7	0.0006
$\Delta P_{tie}$ ST (s)	12.42	10.0091	2.44	$1.48 \times 10^0$	1.798	1.6882	0.1	1.2946	0.31
$\Delta P_{tie}$ US (Hz)	0.0005	0	$1.75 \times 10^{-3}$	$9.80 \times 10^{-4}$	0.031	0.0237	0	0.0235	0
$\Delta P_{tie}$ OS (Hz)	0.0053	0.003	$1.01 \times 10^{-5}$	$0.00 \times 10^0$	0.19	0.3	0.0001	0.4	0.00023

From Figures 10 and 11, FPIDN FOI in [96] is the best controller. It has the lowest settling time value at 0.31 s. In [88], PIDF had the worst performance in terms of the settling time value. Different techniques and algorithms adopted in different schemes yield different values of transient parameters as shown in both of the figures.

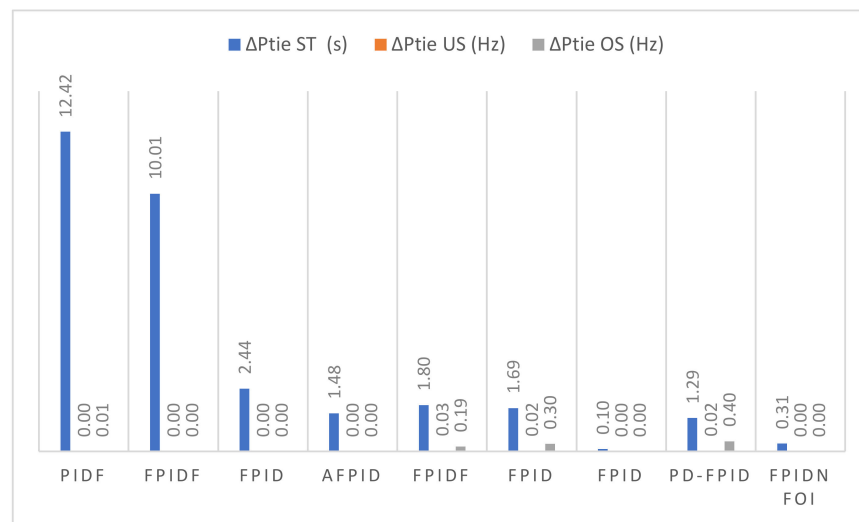

**Figure 10.** Frequency Deviation for Interconnected Systems.

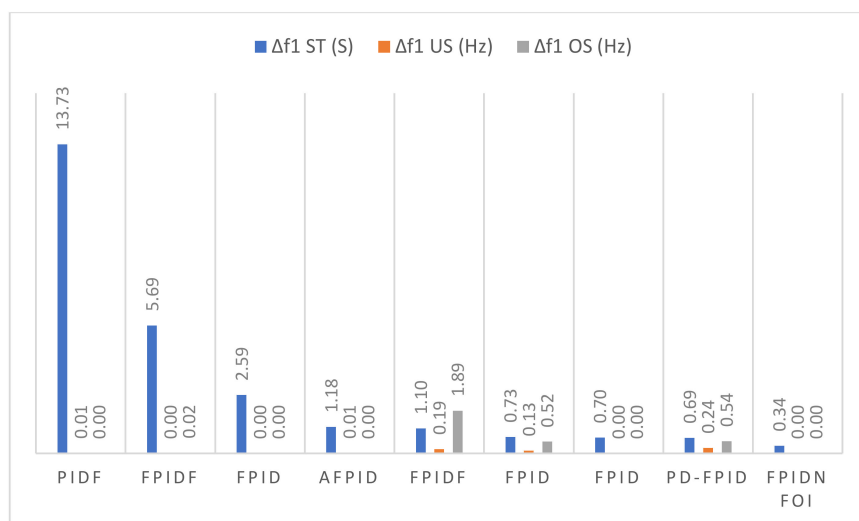

**Figure 11.** Frequency Deviation for Interconnected Systems.

Table 4 shows the performance indices of a fuzzy controller in an isolated power system. In [97], a two-stage adaptive fuzzy approach was adopted for robust frequency



control in an autonomous micro-grid. In [98], FLC-PID was used for a distributed grid system involving wind, hydro and thermal power plants. In [99], improved-GWO was designed for an FO-based type-II fuzzy controller for frequency awareness of an AC micro-grid under plug in an electric vehicle. In [100], optimal controllers were designed for an isolated hybrid wind-diesel power system using the bee algorithm. In [101], coordination strategies were performed on distributed energy resources including fess, DEG, FC and WTG in a load frequency control (LFC) scheme of a hybrid isolated micro-grid.

**Table 4.** Performance Indices of Fuzzy Controller in an Isolated Power System.

Performance Indices	[97] TWO-STAGE FUZZY	[98] FLC-PID	[99] FPID	[100] FPID	[101] FLPID
$\Delta f$ ST (S)	14	13	3.2	2.4	0.6537
$\Delta f$ US (Hz)	5.009	0.009	0.0134	2	0.8924
$\Delta f$ OS (Hz)	5.0009	0.0005	0.0044	0	0.2723

Here, in Table 4 the performance indices of a fuzzy controller in an isolated power system is shown. It is clear that the FLPID has the best performance in terms of settling time, while the two-stage Fuzzy controller has the worst.

The graph in Figure 12 shows that FLPID in [102] is the best FLC controller for isolated systems. The fuzzy logic controllers have implementation issues, and the real-time response deviates significantly from the simulated one. The introduction of transients and addition of delays worsens the performance of fuzzy logic controllers.

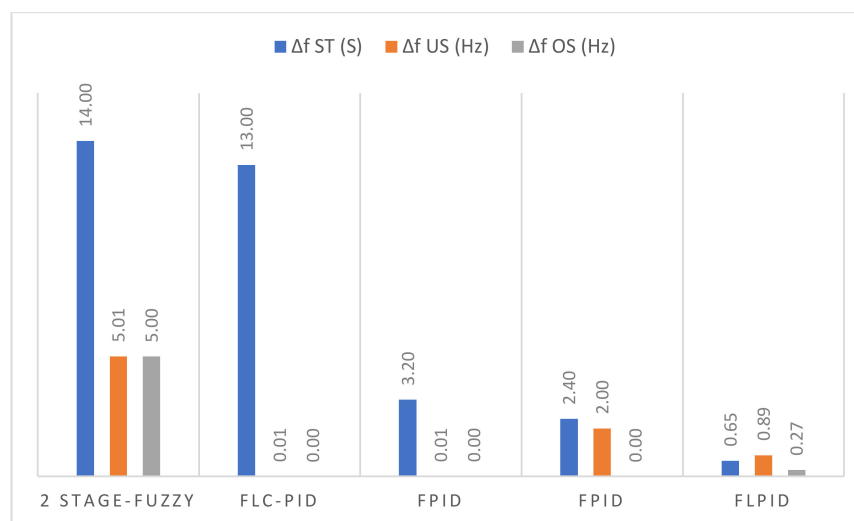

**Figure 12.** Frequency Deviation for Isolated Systems.

### 3.3. Artificial Neural Network (ANN) and Sliding Mode Controllers (SMC)

ANN-based controllers belong to a set of intelligent control devices based on a training set; it observes the events and updates the training set. A set of adaptive training rules is responsible for updating the knowledge of the controller. The ANN observers perform precise estimations of actual variables yielding convergence of estimation to zero. In [102], the authors presented a Fractional Order ANN Controller for LFC of an EVS-Integrated deregulated power system targeting a multi-area solar-thermal power plant and EVs. The proposed topology lowers uncertainties, complexities and non-linearity of the power system, yielding a better dynamic frequency response compared to FOPI, PI and other controllers. In [103], an Artificial Neural Network-tuned PID controller was designed for distributed generation including wind turbine generators, battery energy storage systems, aqua electrolyzers and diesel engine generators. A Sliding Mode Controller is based on a

sliding surface with parameters necessary for frequency regulation. SMC is an advanced controller operating continuously providing a smooth dynamic frequency response with lower non-linearity. In [104], load frequency regulation was performed in an interconnected power system using a second order sliding mode control (SOSMC) combined with a state estimator. The designed controller provides a reduced settling time and lower overshoots. The proposed topology has a robust performance under matched and mismatched uncertainties. The real-time implementation of the control system is possible with accurate parameter adjustments. In [105], frequency regulation was performed using a neural network observer-based controller in the power system. A three-layer feed forward neural network was developed for ANN observer, while the training of data set is performed using the modified adaptive training rule. The results are improved system dynamics with reduced frequency oscillations. It can be seen here in Table 5 that [105] ANN-SMC gives the lowest settling time at 2 s. The [102] FOANN has the worst settling time value at 60 s. The undershoot value is lowest for [13] ANN-PID. The ANN and SMC controllers have complicated structures, and the operation is difficult compared to a simple PID-based controller. It is clear in Figure 13 that ANN-SMC is the best controller in terms of settling time, overshoot and undershoot.

**Table 5.** Performance Indices of ANN Controller in an Interconnected Power System.

Performance Indices	[102] FOANN	[103] ANN-PID	[104] SOSMC	[105] ANN-SMC
$\Delta f_1$ ST (S)	60	6.02	3	2
$\Delta f_1$ US (Hz)	-	0.0021	-	0.028
$\Delta f_1$ OS (Hz)	5	0.1165	$5.00 \times 10^{-5}$	0.012
$\Delta f_2$ ST (s)	60	6	3	2.5
$\Delta f_2$ US (Hz)	-	0.0015	-	0.019
$\Delta f_2$ OS (Hz)	5	0.141	$6.50 \times 10^{-3}$	0.008
$\Delta P_{tie}$ ST (s)	20	6.42	-	-
$\Delta P_{tie}$ US (Hz)	-	0.0006	-	-
$\Delta P_{tie}$ OS (Hz)	5	0.0294	-	-

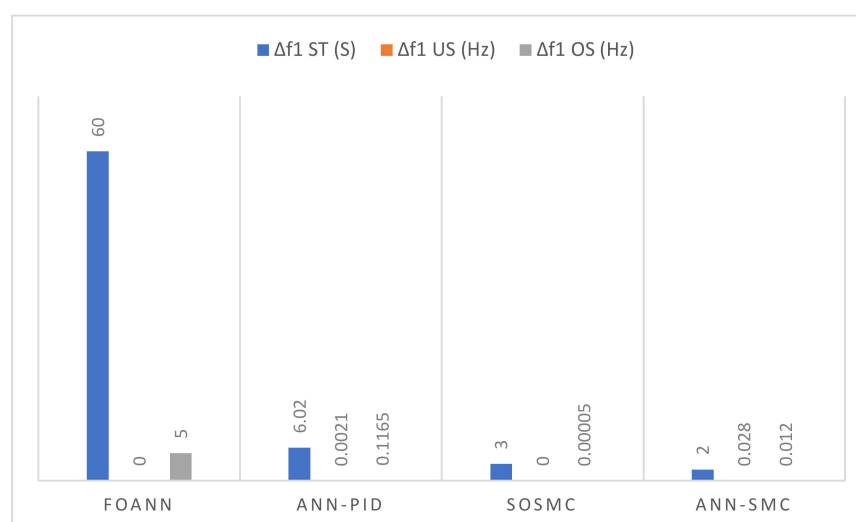

**Figure 13.** Frequency Deviation for Interconnected Systems.

### 3.4. Tilt Integral Derivative Controller

Compared to the conventional PID controllers, TID controllers provide better performance in terms of system dynamics and load disturbances. In [106], optimized TID cooperative controllers were designed for preserving frequency stability in renewable energy-based power system. The proposed topology provides better robustness against

HVDC failure and parameter changes. In [107], the pathfinder algorithm was used for the optimization of fractional order tilt integral derivative (FOTID) controller for AGC control of a multi-source power system; sensitivity and robustness analyses show better settling time and overshoot values. In [108], a cascaded tilt-integral-tilt derivative controller was developed for load frequency regulation in an inter-connected multi-source power system. The TI controller is used as a master controller and TD controller employed as a slave controller, while the optimization of the controller was performed using the Water Cycle Algorithm. The system shows better frequency dynamics under the presence of EVs, proving its robustness. The controller has more efficacy and robustness in terms of dynamic response under various loading conditions. In [109], TID was optimized using the Artificial Bee Colony Optimization (ABCO) algorithm for load frequency control incorporating electric vehicles. The proposed controller has better settling time, peak time and peak overshoot values for 50% variation in governor time constant of steam turbine. In [110], TID is optimized using the Pattern Search Technique for AGC in a deregulated environment. The Super Magnetic Energy Storage (SMES) devices were employed for an optimized dynamic response.

Table 6 discusses the performance indices of the TID controller in an interconnected power system. The settling time decreases from [106] MPSOGA to [110] TLBO-PID. The latter one has the lowest settling time value at 5.82 s.

**Table 6.** Performance Indices of TID Controller in an Interconnected Power System.

Performance Indices	[106] MPSOGA	[107] FOTID	[108] CC-TI-TD	[109] TID-ABCO	[110] TLBO-PID
$\Delta f_1$ ST (S)	25	23.59	13.29	9.5654	5.82
$\Delta f_1$ US (Hz)	0	0.0117	0.01	0	0.253
$\Delta f_1$ OS (Hz)	0.04	0.0026	0.00	0.0241	0.045
$\Delta f_2$ ST (s)	0	18.77	32.10	11.104	0.2312
$\Delta f_2$ US (Hz)	16	0.0068	0.00	0	0.0336
$\Delta f_2$ OS (Hz)	0.03	0.0228	0.00	0.0291	0
$\Delta P_{tie}$ ST (s)	9	23.25	30.70	18.7992	2.53
$\Delta P_{tie}$ US (Hz)	0	0.0044	0.00	0	0.0064
$\Delta P_{tie}$ OS (Hz)	0.023	0.0245	0.00	0.0048	0.05

From Figure 14, it is clear that TLBO-PID gives the lowest settling time value. Figure 15 shows that [84] CC-TI-TD has the worst settling time value. The variation of different techniques yielding different parameters is shown in both Figures 14 and 15. TID controllers show improved values for overshoot and undershoot, but settling time is not good.

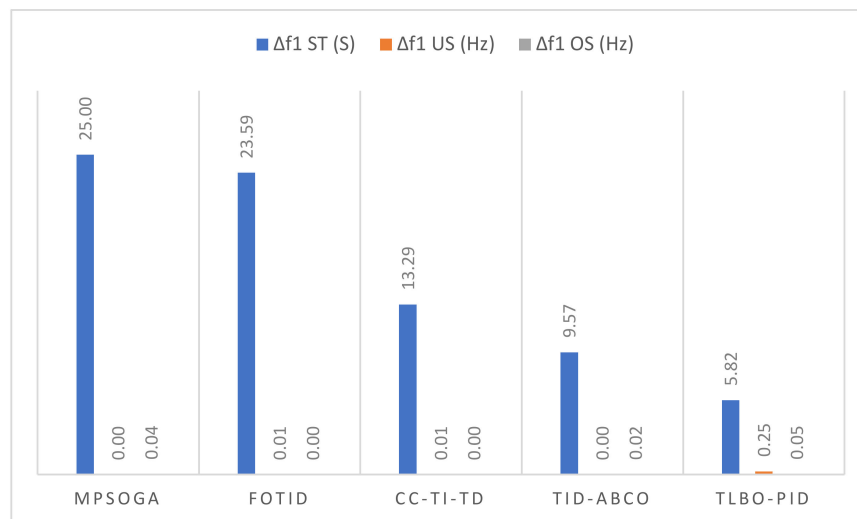

**Figure 14.** Frequency Deviation for Interconnected Systems.

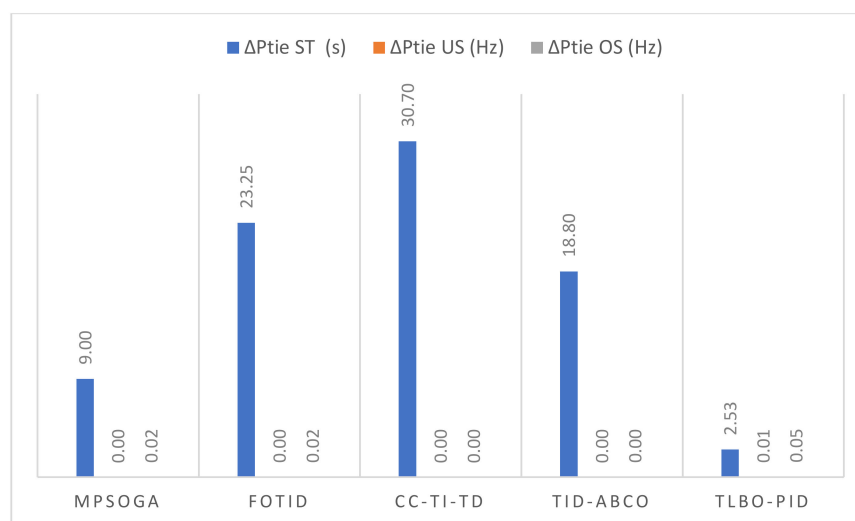

**Figure 15.** Frequency Deviation for Interconnected Systems.

#### 4. Future Scope of Work

Load frequency control is an important issue in the development and operation of a renewable energy-based multi-area power system framework. The focus of the world is shifting more towards the utilization of renewable energy resources, the demand and supply gap, power system structural changes, interconnection of hybrid power systems, vulnerabilities to existing power systems and parameter variations making the power system complex. The LFC design needs improvements, adaptability and reinforcement learning to guarantee sustained operation after extreme unsettling influences. The optimization of multi-area problems with a high degree of diversification in terms of system topologies and control methodologies is critical for meeting the load disturbances and variation in generation profiles. Figure 16 displays a roadmap of LFC development; the development process started with a simple PID-based controller which improved with the use of various optimization algorithms. The Japanese developed fuzzy logic techniques to accommodate the multi-level options between 1 and 0. With the development of fuzzy logic-based LFCs, the load frequency control became more flexible. The Tilt Integral Derivative (TID) controllers developed with a structure similar to PID but with a tilted behavior recognized by transfer function. The FOPID have five parameters instead of three and have a more complex tuning approach. The intelligent algorithms utilized for the development of controllers which can act like human beings receive feedback and act accordingly. In this regard, ANN-based controllers gained popularity which contained a complex neural network that thinks and acts. The Sliding Mode Controller (SMC), a type of non-linear control method, varied the dynamics of a non-linear system with the application of a discontinuous signal. Most of the systems around us are non-linear in nature, and the SMC contained a number of control layers to handle such non-linearities. The Fractional Order Tilt Integral Derivative (FOTID) controller has a structure analogous to (FOPID) a controller but provided better convergence in a number of environments. Development of the FPIDN-FOI controller targeted the multi-area power systems and outperformed the PID/PIDN/FPIDN controllers. The Adaptive Neuro Fuzzy Interface System (ANFIS) was applied to the PID structure to develop an intelligent fuzzy controller which can adapt to its environment. The Model Predictive PI Controller (MPC-PI) was developed to predict the system's future behavior under a set of constraints. The latest development is a two-degrees-of-freedom PID system (2-DOF PID) which accepts two inputs producing one output. It provides a better set point tracking and disturbance rejection phenomenon. The growing power structure demands flexible algorithms, improved controlling structures, an intelligent learning environment and a stable networking structure. In this regard, the LFC structure has improved from time to time for handling non-linearity, parameter variations,

load uncertainties and integration of different resources. The majority of developed LFC structures adapt to a non-linear power system structure using intelligent control methods such as fuzzy logic, ANN and heuristic optimization techniques. In light of the studied literature, the following areas of research are suggested for future LFC development:

- Researching the AI techniques for the training of LFC optimization algorithms to employ the intelligent control of a power system in large networks.
- Accommodating the impact of transmission line congestion into an optimization algorithm of LFC.
- Developing some more robust and adaptive control topologies for LFC development.
- Improving the model predictive function to predict and forecast the environmental variation impacts in LFC design for renewable energy systems.
- Working on the cybersecurity systems to avoid attacks on LFC operation in smart grid structures.
- Development of optimal robust control techniques for LFC in such a way that it can tackle the power production and parameter variations of the system.
- Work to improve the reliability of LFC loops.
- Development of control methods for self-isolation of LFC under fault conditions
- Developing a better interaction between LFC and AVR control loops

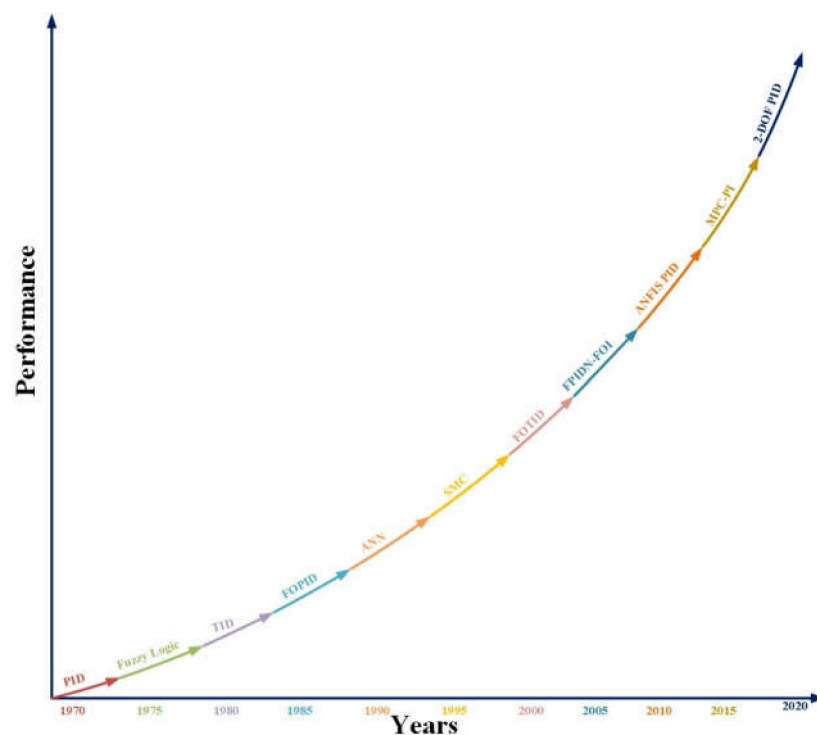

Figure 16. Roadmap of LFC Development.

## 5. Conclusions

LFC is an integral part of modern power systems ensuring consistent, efficient and reliable power delivery. It covers both single-area and multi-area power system categories. The main objective of LFC is to provide frequency regulation in power systems while observing the load demand on a continuous basis under the presence of certain uncertainties, non-linear output and multi-variable power system conditions. This article discusses different topologies of power systems with LFCs optimized using various algorithms. The latest advancements in LFC structure employed in various categories of renewable energy systems are discussed concisely. Finally, this paper ends by signifying the need for future development in the area of Load Frequency Controllers. It is believed that this work will be a useful source of information in the field of load frequency control for renewable energy systems.



**Author Contributions:** Conceptualization, M.M.G., M.I. and S.S.; Methodology, H.A.M., M.S. and S.S.; Writing—Original Draft, M.I.; Supervision, M.M.G.; Funding, M.M.H. and H.A.M. All authors have read and agreed to the published version of the manuscript.

**Funding:** The researchers would like to thank the partnership and engagement programme funding, University of South Wales, UK.

**Institutional Review Board Statement:** Not applicable.

**Informed Consent Statement:** Not applicable.

**Data Availability Statement:** Not applicable.

**Conflicts of Interest:** The authors declare no conflict of interest.

## References

1. Çam, E.; Kocaarslan, I. Load frequency control in two area power systems using fuzzy logic controller. *Energy Convers. Manag.* **2005**, *46*, 233–243. [\[CrossRef\]](#)
2. Khodabakhshian, A.; Hooshmand, R. A new PID controller design for automatic generation control of hydro power systems. *Int. J. Electr. Power Energy Syst.* **2010**, *32*, 375–382. [\[CrossRef\]](#)
3. Daud, S.; Ali, M.; Naveed, A.; Hadeed, A.S.; Muhammad, G. Multi Control Adaptive Fractional Order PID Control Approach for PV/Wind Connected Grid System. *Int. Trans. Electr. Energy Syst.* **2021**, *31*, e12809.
4. Hsu, Y.Y.; Chan, W.C. Optimal variable structure controller for the load-frequency control of interconnected hydrothermal power systems. *Int. J. Electr. Power Energy Syst.* **1984**, *6*, 221–229. [\[CrossRef\]](#)
5. Verma, Y.P.; Kumar, A. Load frequency control in deregulated power system with wind integrated system using fuzzy controller. *Front. Energy* **2013**, *7*, 245–254. [\[CrossRef\]](#)
6. Hasanien, H.M. Whale optimisation algorithm for automatic generation control of interconnected modern power systems including renewable energy sources. *IET Gener. Transm. Distrib.* **2018**, *12*, 607–614. [\[CrossRef\]](#)
7. Yousef, H.A.; Al-Kharusi, K.; Albadi, M.H.; Hosseinzadeh, N. Load frequency control of a multi-area power system: An adaptive fuzzy logic approach. *IEEE Trans. Power Syst.* **2014**, *29*, 1822–1830. [\[CrossRef\]](#)
8. Shiva, C.K.; Mukherjee, V. A novel quasi-oppositional harmony search algorithm for automatic generation control of power system. *Appl. Soft Comput. J.* **2015**, *35*, 749–765. [\[CrossRef\]](#)
9. Snehal, G.; Krishan, A. Automatic generation control of multi area power plants with the help of advanced controller. *Int. J. Eng. Res.* **2015**, *V4*, 470–474.
10. Shiroei, M.; Toulabi, M.R.; Ranjbar, A.M. Robust multivariable predictive based load frequency control considering generation rate constraint. *Int. J. Electr. Power Energy Syst.* **2013**, *46*, 405–413. [\[CrossRef\]](#)
11. Haes Alhelou, H.; Hamedani Golshan, M.E.; Hajiakbari Fini, M. Wind Driven Optimization Algorithm Application to Load Frequency Control in Interconnected Power Systems Considering GRC and GDB Non Linearities. *Electr. Power Compon. Syst.* **2018**, *46*, 1223–1238. [\[CrossRef\]](#)
12. Jagatheesan, K.; Anand, B.; Samanta, S.; Dey, N.; Santhi, V.; Ashour, A.S.; Balas, V.E. Application of flower pollination algorithm in load frequency control of multi-area interconnected power system with nonlinearity. *Neural Comput. Appl.* **2017**, *28*, 475–488. [\[CrossRef\]](#)
13. Khooban, M.H.; Niknam, T. A new intelligent online fuzzy tuning approach for multiarea load frequency control: Self adaptive modified bat algorithm. *Int. J. Electr. Power Energy Syst.* **2015**, *71*, 254–261. [\[CrossRef\]](#)
14. Padhan, D.G.; Majhi, S. A new control scheme for PID load frequency controller of single-area and multi-area power systems. *ISA Trans.* **2013**, *52*, 242–251. [\[CrossRef\]](#) [\[PubMed\]](#)
15. Rehman, U.U.; Jameel, A.; Khan, A.; Gulzar, M.M.; Murawwat, S. Load Frequency Management for a two-area system (Thermal-PV & Hydel-PV) by Swarm Optimization based Intelligent Algorithms. In Proceedings of the 2021 International Conference on Emerging Power Technologies (ICEPT), Topi, Pakistan, 10–11 April 2021; pp. 1–6. [\[CrossRef\]](#)
16. Bhongade, S.; Gupta, H.O.; Tyagi, B. Artificial neural network based automatic generation control scheme for deregulated electricity market. In Proceedings of the 2010 Conference Proceedings IPEC, Singapore, 27–29 October 2010; pp. 1158–1163.
17. Ameli, A.; Hooshyar, A.; Yazdavar, A.H.; El-Saadany, E.F.; Youssef, A. Attack detection for load frequency control systems using stochastic unknown input estimators. *IEEE Trans. Inf. Forensics Secur.* **2018**, *13*, 2575–2590. [\[CrossRef\]](#)
18. Chandra Sekhar, G.T.; Sahu, R.K.; Baliarsingh, A.K.; Panda, S. Load frequency control of power system under deregulated environment using optimal firefly algorithm. *Int. J. Electr. Power Energy Syst.* **2016**, *74*, 195–211. [\[CrossRef\]](#)
19. Pappachen, A.; Peer Fathima, A. Load frequency control in deregulated power system integrated with SMES-TCPS combination using ANFIS controller. *Int. J. Electr. Power Energy Syst.* **2016**, *82*, 519–534. [\[CrossRef\]](#)
20. Arya, Y.; Kumar, N. AGC of a multi-area multi-source hydrothermal power system interconnected via AC/DC parallel links under deregulated environment. *Int. J. Electr. Power Energy Syst.* **2016**, *75*, 127–138. [\[CrossRef\]](#)
21. Mohanty, B.; Hota, P.K. Comparative performance analysis of fruit fly optimization algorithm for multi-area multisource automatic generation control under deregulated environment. *IET Gener. Transm. Distrib.* **2015**, *9*, 1845–1855. [\[CrossRef\]](#)

22. Falahati, S.; Taher, S.A.; Shahidehpour, M. Grid frequency control with electric vehicles by using of an optimized fuzzy controller. *Appl. Energy* **2016**, *178*, 918–928. [[CrossRef](#)]
23. Mahmood, H.; Michaelson, D.; Jiang, J. Decentralized power management of a PV/ battery hybrid unit in a droop-controlled islanded microgrid. *IEEE Trans. Power Electron.* **2015**, *30*, 7215–7229. [[CrossRef](#)]
24. Shankar, G.; Mukherjee, V. Load frequency control of an autonomous hybrid power system by quasi-oppositional harmony search algorithm. *Int. J. Electr. Power Energy Syst.* **2016**, *78*, 715–734. [[CrossRef](#)]
25. Yousri, D.; Sudhakar, T.; Fathy, A. Recent methodology based Harris Hawks optimizer for designing load frequency control incorporated in multi-interconnected renewable energy plants. *Sustain. Energy Grids Netw.* **2020**, *22*, 100352. [[CrossRef](#)]
26. Sahu, R.K.; Gorripotu, T.S.; Panda, S. A hybrid DE–PS algorithm for load frequency control under deregulated power system with UPFC and RFB. *Ain Shams Eng. J.* **2015**, *6*, 893–911. [[CrossRef](#)]
27. Kler, D.; Kumar, V.; Rana, K.P.S. Optimal integral minus proportional derivative controller design by evolutionary algorithm for thermal-renewable energy-hybrid power systems. *IET Renew. Power Gener.* **2019**, *13*, 2000–2012. [[CrossRef](#)]
28. Qadikolai, M.H. Frequency control of isolated hybride power netowtk using genethic algorithm and particle swarm optimization. In Proceedings of the 2015 30th International Power System Conference (PSC), Tehran, Iran, 23–25 November 2015; Volume 3, pp. 184–189.
29. Latif, A.; Das, D.C. Performance analysis of CSA optimized PIDF controller for containing frequency fluctuation of micro-grid. In Proceedings of the 2018 3rd International Conference for Convergence in Technology (I2CT), Pune, India, 6–8 April 2018; pp. 1–6.
30. Sharma, D.; Yadav, N.K. Lion Algorithm with Levy Update: Load frequency controlling scheme for two-area interconnected multi-source power system. *Trans. Inst. Meas. Control* **2019**, *41*, 4084–4099. [[CrossRef](#)]
31. Jain, S.; Hote, Y.V. Design of fractional PID for Load frequency control via Internal model control and Big bang Big crunch optimization. *IFAC-Pap. OnLine* **2018**, *51*, 610–615. [[CrossRef](#)]
32. Debbarma, S.; Saikia, L.C.; Sinha, N. Automatic generation control using two degree of freedom fractional order PID controller. *Int. J. Electr. Power Energy Syst.* **2014**, *58*, 120–129. [[CrossRef](#)]
33. Chathoth, I.; Ramdas, S.K.; Krishnan, S.T. Fractional-order proportional-integral-derivative-based automatic generation control in deregulated power systems. *Electr. Power Compon. Syst.* **2015**, *43*, 1931–1945. [[CrossRef](#)]
34. Sondhi, S.; Hote, Y.V. Fractional order PID controller for perturbed load frequency control using Kharitonov’s theorem. *Int. J. Electr. Power Energy Syst.* **2016**, *78*, 884–896. [[CrossRef](#)]
35. Saxena, S. Load frequency control strategy via fractional-order controller and reduced- order modeling. *Int. J. Electr. Power Energy Syst.* **2019**, *104*, 603–614. [[CrossRef](#)]
36. Nithilaravanan, K.; Thakwani, N.; Mishra, P.; Kumar, V.; Rana, K.P.S. Efficient control of integrated power system using self-tuned fractional-order fuzzy PID controller. *Neural Comput. Appl.* **2019**, *31*, 4137–4155. [[CrossRef](#)]
37. Wang, H.; Zeng, G.; Dai, Y.; Bi, D.; Sun, J.; Xie, X. Design of a fractional order frequency PID controller for an islanded microgrid: A multi-objective extremal optimization method. *Energies* **2017**, *10*, 1502. [[CrossRef](#)]
38. Dash, P.; Saikia, L.C.; Sinha, N. Flower pollination algorithm optimized PI-PD cascade controller in automatic generation control of a multi-area power system. *Int. J. Electr. Power Energy Syst.* **2016**, *82*, 19–28. [[CrossRef](#)]
39. Pandey, S.K.; Kishor, N.; Mohanty, S.R. Frequency regulation in hybrid power system using iterative proportional-integral-derivative  $H_{\infty}$  controller. *Electr. Power Compon. Syst.* **2014**, *42*, 132–148. [[CrossRef](#)]
40. Rahman, A.; Saikia, L.C.; Sinha, N. Load frequency control of a hydro-thermal system under deregulated environment using biogeography-based optimised three-degree- of-freedom integral-derivative controller. *IET Gener. Transm. Distrib.* **2015**, *9*, 2284–2293. [[CrossRef](#)]
41. Golpıra, H.; Bevrani, H. A framework for economic load frequency control design using modified multi-objective genetic algorithm. *Electr. Power Compon. Syst.* **2014**, *42*, 788–797. [[CrossRef](#)]
42. Sahu, B.K.; Pati, S.; Panda, S. Hybrid differential evolution particle swarm optimization optimised fuzzy proportional-integral derivative controller for automatic generation control of interconnected power system. *IET Gener. Transm. Distrib.* **2014**, *8*, 1789–1800. [[CrossRef](#)]
43. Bahgaat, N.K.; El-Sayed, M.I.; Hassan, M.A.M.; Bendary, F.A. Load frequency control in power system via improving PID controller based on particle swarm optimization and ANFIS techniques. *Int. J. Syst. Dyn. Appl.* **2014**, *3*, 1–24. [[CrossRef](#)]
44. Malik, H.; Mahto, V.M.T. *Fractional Order Control and Simulation of Wind-Biomass Isolated Hybrid Power System Using Particle Swarm Optimization*; Springer: Singapore, 2019; Volume 698.
45. Abdelaziz, A.Y.; Ali, E.S. Cuckoo Search algorithm based load frequency controller design for nonlinear interconnected power system. *Int. J. Electr. Power Energy Syst.* **2015**, *73*, 632–643. [[CrossRef](#)]
46. Chainé, S.; Tripathy, M.; Jain, D. Non dominated Cuckoo search algorithm optimized controllers to improve the frequency regulation characteristics of wind thermal power system. *Eng. Sci. Technol. Int. J.* **2017**, *20*, 1092–1105. [[CrossRef](#)]
47. Gheisarnejad, M. An effective hybrid harmony search and cuckoo optimization algorithm based fuzzy PID controller for load frequency control. *Appl. Soft Comput.* **2018**, *65*, 121–138. [[CrossRef](#)]
48. Ali, E.S.; Abd-Elazim, S.M. BFOA based design of PID controller for two area Load Frequency Control with nonlinearities. *Int. J. Electr. Power Energy Syst.* **2013**, *51*, 224–231. [[CrossRef](#)]
49. Dhillon, S.S.; Lather, J.S.; Marwaha, S. Multi objective load frequency control using hybrid bacterial foraging and particle swarm optimized PI controller. *Int. J. Electr. Power Energy Syst.* **2016**, *79*, 196–209. [[CrossRef](#)]

50. Qian, D.; Tong, S.; Liu, H.; Liu, X. Load frequency control by neural-network-based integral sliding mode for nonlinear power systems with wind turbines. *Neurocomputing* **2016**, *173*, 875–885. [[CrossRef](#)]
51. Prakash, S.; Sinha, S.K. Simulation based neuro-fuzzy hybrid intelligent PI control approach in four-area load frequency control of interconnected power system. *Appl. Soft Comput.* **2014**, *23*, 152–164. [[CrossRef](#)]
52. Zhang, F.; Li, Q. Deep learning-based data forgery detection in automatic generation control. In Proceedings of the 2017 IEEE Conference on Communications and Network Security (CNS), Las Vegas, NV, USA, 9–11 October 2017; pp. 400–404.
53. Ulbig, A.; Rinke, T.; Chatzivasileiadis, S.; Andersson, G. Predictive control for real-time frequency regulation and rotational inertia provision in power systems. In Proceedings of the 52nd IEEE Conference on Decision and Control, Florence, Italy, 10–13 December 2013; pp. 2946–2953.
54. Shiroei, M.; Ranjbar, A.M. Supervisory predictive control of power system load frequency control. *Int. J. Electr. Power Energy Syst.* **2014**, *61*, 70–80. [[CrossRef](#)]
55. Anwar, M.N.; Pan, S. A new PID load frequency controller design method in frequency domain through direct synthesis approach. *Int. J. Electr. Power Energy Syst.* **2015**, *67*, 560–569. [[CrossRef](#)]
56. Liu, X.; Kong, X.; Lee, K.Y. Distributed model predictive control for load frequency control with dynamic fuzzy valve position modelling for hydro-thermal power system. *IET Control Theory Appl.* **2016**, *10*, 1653–1664. [[CrossRef](#)]
57. Hanan, M.; Javed, M.Y.; Ai, X.; Gulzar, M.M.; Ahmad, S. A Two-Stage Algorithm to Harvesting Maximum Power from Photovoltaic System. In Proceedings of the IEEE International Conference on Energy Internet and Energy System Integration (EI2), Beijing, China, October 2018; pp. 1–6.
58. Javed, M.Y.; Murtaza, A.F.; Ling, Q.; Qamar, S.; Gulzar, M.M. A Novel MPPT design using Generalized Pattern Search for Partial Shading. *Energy Build.* **2016**, *133*, 59–69. [[CrossRef](#)]
59. Qi, X.; Bai, Y. Improved linear active disturbance rejection control for microgrid frequency regulation. *Energies* **2017**, *10*, 1047. [[CrossRef](#)]
60. Xie, M.; Gulzar, M.M.; Tehreem, H.; Javed, M.Y.; Rizvi, S.T.H. Automatic Voltage Regulation of Grid Connected Photovoltaic System Using Lyapunov Based Sliding Mode Controller: A Finite-Time Approach. *Int. J. Control. Autom. Systems.* **2020**, *18*, 1550–1560. [[CrossRef](#)]
61. Hirsch, A.; Parag, Y.; Guerrero, J. Microgrids: A review of technologies, key drivers, and outstanding issues. *Renew. Sustain. Energy Rev.* **2018**, *90*, 402–411. [[CrossRef](#)]
62. Khan, F.U.; Gulzar, M.M.; Sibtain, D.; Usman, H.M.; Hayat, A. Variable step size fractional incremental conductance for MPPT under changing atmospheric conditions. *Int. J. Numer. Model. Electron. Netw. Devices Fields.* **2020**, *33*, 1–18.
63. Gulzar, M.M.; Sharif, B.; Iqbal, S.; Javed, M.Y.; Sibtain, D. Management of Energy and Comfort Facilities in Modern Buildings using Fuzzy Logic. *New Horiz. J. Inst. Electr. Electron. Eng. Pakistan* **2017**, *91–96*, 30–34.
64. Gulzar, M.; Rizvi, S.; Javed, M.; Sibtain, D.; Din, R.S.U. Mitigating the load frequency fluctuations of interconnected power systems using Model Predictive Controller. *Electronics* **2019**, *8*, 156. [[CrossRef](#)]
65. Patel, N.C.; Debnath, M.K.; Sahu, B.K.; Dash, S.S.; Bayindir, R. Application of Invasive Weed Optimization Algorithm to optimally design Multi-staged PID controller for LFC Analysis. *Int. J. Renew. Energy Res.* **2019**, *9*, 470–479.
66. Javed, H.; Muqet, H.A.; Shehzad, M.; Jamil, M.; Khan, A.A.; Guerrero, J.M. Optimal Energy Management of a Campus Microgrid Considering Financial and Economic Analysis with Demand Response Strategies. *Energies*. **2021**, *14*, 8501. [[CrossRef](#)]
67. Anbarasi, S.; Muralidharan, S. Hybrid BFPSO approach for effective tuning of PID controller for Load Frequency Control Application in an interconnected power system. *J. Electr. Eng. Technol.* **2017**, *12*, 1027–1037. [[CrossRef](#)]
68. Guha, D.; Roy, P.K.; Banerjee, S. Symbiotic organism search algorithm applied to load frequency control of multi-area Power System. *Energy Syst.* **2017**, *9*, 439–468. [[CrossRef](#)]
69. Elsaied, M.M.; Attia, M.A.; Mostafa, M.A.; Mekhamer, S.F. Application of different optimization techniques to Load frequency control with WECS in A Multi-Area System. *Electr. Power Compon. Syst.* **2018**, *46*, 739–756. [[CrossRef](#)]
70. Guha, D.; Roy, P.K.; Banerjee, S. Application of backtracking search algorithm in load frequency control of multi-area interconnected power system. *Ain Shams Eng. J.* **2018**, *9*, 257–276. [[CrossRef](#)]
71. Bhongade, S. Automatic generation control of two-area ST-Thermal power system using jaya algorithm. *Int. J. Smart Grid* **2018**, *2*, 99–110.
72. Shah, J.S.; Suleyman, S.T.; Ibrahim, K.; Zakirhussain, F. Gravitational Search Algorithm (GSA) based PID Controller Design for Two Area Multi-Source Power System Load Frequency Control. *J. Control Sci.* **2018**, *31*, 139–153.
73. Prasun, S.; Basu, M. New approach in two-area interconnected AGC including various renewable energy sources Using PSO. *Turk. J. Electr. Eng. Comput. Sci.* **2018**, *26*, 1491–1504.
74. Annamraju, A.; Nandiraju, S. Coordinated control of conventional power sources and PHEVs using jaya algorithm optimized PID controller for frequency control of a renewable penetrated power system. *Prot. Control Mod. Power Syst.* **2019**, *4*, 1–13. [[CrossRef](#)]
75. Dey, P.P.; Das, D.C.; Latif, A.; Hussain, S.M.; Ustun, T.S. Active power management of virtual power plant UNDER penetration of CENTRAL Receiver SOLAR Thermal-Wind using Butterfly optimization technique. *Sustainability* **2020**, *12*, 6979. [[CrossRef](#)]
76. Kong, F.; Li, J.; Yang, D. Multi-Area load frequency control of hydro-thermal-wind power based on improved grey Wolf optimization algorithm. *Elektron. Ir Elektrotehnika* **2020**, *26*, 32–39. [[CrossRef](#)]
77. Abo-Elyousr, F.K.; Abdelaziz, A.Y. A novel modified robust load frequency control for mass-less inertia photovoltaics penetrations via hybrid PSO-Woa Approach. *Electr. Power Compon. Syst.* **2019**, *47*, 1744–1758. [[CrossRef](#)]



78. Zaheeruddin; Singh, K. Primary frequency regulation of a microgrid by deloaded tidal turbines. *Soft Comput.* **2020**, *24*, 14667–14685. [[CrossRef](#)]
79. Alattar, H.; Selem, S.I.; Metwally, H.M.; Ibrahim, A.; Aboelsaud, R.; Tolba, M.A.; El-Rifaie, A.M. Performance enhancement of micro grid system with smes storage system based on mine blast optimization algorithm. *Energies* **2019**, *12*, 3110. [[CrossRef](#)]
80. Ranjan, S.; Das, D.C.; Behera, S.; Sinha, N. Parabolic trough solar–thermal–wind–diesel isolated hybrid power system: Active power/frequency control analysis. *IET Renew. Power Gener.* **2018**, *12*, 1893–1903. [[CrossRef](#)]
81. Annamraju, A.; Nandiraju, S. *A Novel Fuzzy Tuned Multistage PID Approach for Frequency Dynamics Control in an Islanded Microgrid*; John Wiley & Sons: Hoboken, NJ, USA, 2020.
82. Singh, A.; Suhag, S. Frequency regulation in AC microgrid with and without electric vehicle using multiverse-optimized fractional order- PID controller. *Int. J. Comput. Digit. Syst.* **2019**, *8*, 375–385. [[CrossRef](#)]
83. Fayek, H.H.; Mohammadi-Ivatloo, B. Tidal supplementary CONTROL Schemes-Based Load frequency regulation of a fully Sustainable Marine Microgrid. *Inventions* **2020**, *5*, 53. [[CrossRef](#)]
84. Kumar; Shankar, G. Quasi-oppositional harmony search algorithm based optimal dynamic load frequency control of a hybrid tidal–diesel power generation system. *IET Gener. Transm. Distrib.* **2018**, *12*, 1099–1108. [[CrossRef](#)]
85. Jumani, T.; Mustafa, M.; Rasid, M.; Mirjat, N.; Baloch, M.; Salisu, S. Optimal Power Flow Controller for grid-connected microgrids using grasshopper optimization algorithm. *Electronics* **2019**, *8*, 111. [[CrossRef](#)]
86. Hussain, I.; Ranjan, S.; Das, D.C.; Sinha, N. Performance analysis of flower pollination algorithm optimized pid controller for wind-PV-SMES-BESS-Diesel Autonomous hybrid Power System. *Int. J. Renew. Energy Res.* **2017**, *7*, 643–651.
87. Arora, K.; Kumar, A.; Kamboj, V.K.; Prashar, D.; Shrestha, B.; Joshi, G.P. Impact of renewable energy sources into multi area multi-source load frequency control of interrelated power system. *Mathematics* **2021**, *9*, 186. [[CrossRef](#)]
88. Boddepalli, M.K.; Pilla, R.; Gorripotu, T.S.; Kumar, D.V. Design and analysis OF bfoa OPTIMISED PID controller with Derivative filter for frequency regulation in distributed generation system. *Int. J. Autom. Control* **2018**, *12*, 291. [[CrossRef](#)]
89. Kumar, A.; Suhag, S. Effect of TCPS, smes, and DFIG on load frequency control of a multi-area multi-source power system using multi-verse optimized fuzzy-PID controller with derivative filter. *J. Vib. Control* **2017**, *24*, 5922–5937. [[CrossRef](#)]
90. Lal, D.K.; Barisal, A.K.; Tripathy, M. Load frequency control of Multi Source Multi-Area nonlinear power system with De-pso Optimized Fuzzy pid controller in coordination With SSSC and RFB. *Int. J. Control Autom.* **2018**, *11*, 61–80. [[CrossRef](#)]
91. Padhy, S.; Panda, S. Application of a simplified grey wolf optimization technique for adaptive fuzzy PID controller design for Frequency Regulation of a distributed power generation system. *Prot. Control Mod. Power Syst.* **2021**, *6*, 1–16. [[CrossRef](#)]
92. Debnath, M.K.; Sinha, S.; Mallick, R.K. Application of fuzzy-PIDF controller for automatic generation control using termite correlation PSO algorithm. *Int. Rev. Autom. Control* **2017**, *10*, 380. [[CrossRef](#)]
93. Debnath, M.K.; Mallick, R.K.; Sahu, B.K. Application of hybrid differential evolution–grey wolf optimization algorithm for automatic generation control of a multi-source interconnected power system using Optimal Fuzzy–Pid Controller. *Electr. Power Compon. Syst.* **2017**, *45*, 2104–2117. [[CrossRef](#)]
94. Badal, R.; Nayem, Z.; Sarker, S.K.; Datta, D.; Fahim, S.R.; Muyeen, S.M.; Sheikh, M.R.I.; Das, S.K. A novel intrusion mitigation unit for interconnected power systems in frequency regulation to enhance cybersecurity. *Energies* **2021**, *14*, 1401. [[CrossRef](#)]
95. Debnath, M.K.; Jena, T.; Mallick, R.K. Optimal design of Pd-Fuzzy-PID cascaded controller for Automatic Generation Control. *Cogent Eng.* **2017**, *4*, 1416535. [[CrossRef](#)]
96. Arya, Y. Improvement in automatic generation control OF Two-area electric power systems via a new Fuzzy aided optimal Pidn-foi controller. *ISA Trans.* **2018**, *80*, 475–490. [[CrossRef](#)]
97. Annamraju, A.; Nandiraju, S. Robust frequency control in an Autonomous MICROGRID: A TWO-STAGE adaptive fuzzy approach. *Electr. Power Compon. Syst.* **2018**, *46*, 83–94. [[CrossRef](#)]
98. Raju, G.R.; Reddy, S. Analysis of load frequency control for a distributed grid system involving wind, hydro and thermal power plants using conventional and fuzzy logic controller. *IRJET* **2019**, *6*, 4361–4366.
99. Sahu, P.C.; Prusty, R.C.; Panda, S. Improved-gwo designed FO based type-II fuzzy controller for frequency awareness of an AC microgrid under plug in Electric Vehicle. *J. Ambient Intell. Humaniz. Comput.* **2020**, *12*, 1879–1896. [[CrossRef](#)]
100. Wichan, S.; Warawat, S.-N. Optimal controllers design for isolated hybrid wind-diesel power system using bee algorithm. *Rev. Roum. Sci. Tech.* **2019**, *64*, 341–348.
101. Abazari, A.; Monsef, H.; Wu, B. Coordination strategies of distributed energy resources including fess, DEG, FC and WTG in Load Frequency Control (LFC) scheme of hybrid isolated micro-grid. *Int. J. Electr. Power Energy Syst.* **2019**, *109*, 535–547. [[CrossRef](#)]
102. Saraswati, S.; Reddy, B.R.; Kalavathi, M.S. Fractional Order ANN Controller for LFC of EVS integrated deregulated power system. *Int. J. Adv. Res. Eng. Technol.* **2020**, *11*, 13–27.
103. Debnath, M.K.; Agrawal, R.; Tripathy, S.R.; Choudhury, S. Artificial Neural Network Tuned Pid Controller for LFC investigation including Distributed Generation. *Int. J. Numer. Model. Electron. Netw. Devices Fields* **2020**, *33*, e2740. [[CrossRef](#)]
104. Tran, A.-T.; Minh, B.L.; Huynh, V.V.; Tran, P.T.; Amaefule, E.N.; Phan, V.-D.; Nguyen, T.M. Load frequency regulator in interconnected power system using second-order sliding mode control combined with state estimator. *Energies* **2021**, *14*, 863. [[CrossRef](#)]
105. Prasad, S.; Ansari, M.R. Frequency regulation using neural network observer based controller in power system. *Control Eng. Pract.* **2020**, *102*, 104571. [[CrossRef](#)]

106. Elmelegi, A.; Mohamed, E.A.; Aly, M.; Ahmed, E.M.; Mohamed, A.-A.A.; Elbaksawi, O. Optimized tilt fractional order cooperative controllers for preserving frequency stability in renewable energy-based Power Systems. *IEEE Access* **2021**, *9*, 8261–8277. [[CrossRef](#)]
107. Priyadarshani, S.; Subhashini, K.R.; Satapathy, J.K. Pathfinder algorithm OPTIMIZED fractional order tilt-integral-derivative (FOTID) controller for automatic generation control of multi-source power system. *Microsyst. Technol.* **2020**, *27*, 23–35. [[CrossRef](#)]
108. Kumari, S.; Shankar, G. Maiden application of Cascade tilt-integral–tilt-derivative controller for performance analysis of load frequency control of interconnected multi-source power system. *IET Gener. Transm. Distrib.* **2019**, *13*, 5326–5338. [[CrossRef](#)]
109. Oshnoei, A.; Khezri, R.; Muyeen, S.M.; Oshnoei, S.; Blaabjerg, F. Automatic Generation Control Incorporating Electric Vehicles. *Electr. Power Compon. Syst.* **2019**, *47*, 720–732. [[CrossRef](#)]
110. Khamari, D.; Sahu, R.K.; Gorripotu, T.S.; Panda, S. Automatic Generation Control of power system in deregulated environment using hybrid TLBO and pattern search technique. *Ain Shams Eng. J.* **2020**, *11*, 553–573. [[CrossRef](#)]