

## Article

# Numerical Study for the Evaluation of the Effectiveness and Benefits of Using Photovoltaic-Thermal (PV/T) System for Hot Water and Electricity Production under a Tropical African Climate: Case of Comoros

Fahad Maoulida <sup>1,2</sup>, Rabah Djedjig <sup>1,\*</sup> , Mohamed Aboudou Kassim <sup>2,3</sup> and Mohammed El Ganaoui <sup>1</sup>

<sup>1</sup> Laboratory of Studies and Research on Wood Material, IUT of Longwy, University of Lorraine, 186 rue de Lorraine, 54400 Cosnes-et-Romain, France

<sup>2</sup> Energy and Applied Mechanics Laboratory, Faculty of Sciences and Techniques, University of Comoros, Moroni 99999, Comoros

<sup>3</sup> IREMIS Institute, CUFR, University of Mayotte, 97660 Dembeni, France

\* Correspondence: rabah.djedjig@univ-lorraine.fr

**Abstract:** Several rural regions located in Africa are experiencing recurrent and even permanent problems in terms of energy production, supply, and distribution to citizens. This study was conducted to investigate the relevance of the use of a new solar technology that is gradually responding in Europe and in industrialized countries. It is about the use of hybrid photovoltaic thermal (PV/T) solar panels that co-produce electricity and hot water for local use. Furthermore, in Africa, local use of solar energy can provide a share in the energy mix. This work is motivated by the lack of studies on these hybrid solar panels in tropical climates. Hence, the paper examines the potential for integration of these systems in small households. A complete PV/T system consisting of solar panels, pump, storage tank, batteries, and controllers was tested and calibrated by using the TRNSYS simulation tool. A comparative study could thus be carried out for the performance of PV/T in a tropical climate (case of the city of Koua in the Comoros) to its performance in Mediterranean and continental climates (Marseille in the south and Longwy in the northeast of France). The results quantify the performance of the PV/T in the three climates and show that the performance in the town of Koua is 44% to 54% higher than in European climates. It can be concluded from this study that the Comorian market and more generally the sub-Saharan market for PVT systems has a good potential for development.

**Keywords:** energy challenge in Africa; photovoltaic solar thermal PV/T; energy demand; hot water supply; modeling and simulations



**Citation:** Maoulida, F.; Djedjig, R.; Kassim, M.A.; El Ganaoui, M. Numerical Study for the Evaluation of the Effectiveness and Benefits of Using Photovoltaic-Thermal (PV/T) System for Hot Water and Electricity Production under a Tropical African Climate: Case of Comoros. *Energies* **2023**, *16*, 240. <https://doi.org/10.3390/en16010240>

Academic Editors: José Luis Domínguez-García, Ayman Attya and Olimpo Anaya-Lara

Received: 30 November 2022

Revised: 19 December 2022

Accepted: 21 December 2022

Published: 26 December 2022



**Copyright:** © 2022 by the authors. Licensee MDPI, Basel, Switzerland. This article is an open access article distributed under the terms and conditions of the Creative Commons Attribution (CC BY) license (<https://creativecommons.org/licenses/by/4.0/>).

## 1. Introduction

Solar energy is usually collected as heat and electricity by thermal and photovoltaic (PV) technologies. A hybrid photovoltaic-thermal (PV/T) system incorporates a solar thermal absorber and a PV in a single device. While photovoltaic cells produce electricity, the integrated thermal system absorbs the residual thermal energy from the cells and thus reduces their temperature during the process and improves their efficiency [1–3]. PV/T systems are a type of micro-cogeneration technology that can be easily and efficiently integrated into buildings. This makes it possible to have a decentralized production of clean heat and energy, to optimize building covering, and to obtain a better return on investment compared to photovoltaic and thermal panels separated side by side [4].

The two most commonly used operating fluids are water and air. However, water panels are more thermally efficient [5,6]. These hybrid PV/T systems can achieve up to an overall efficiency of 70% for the most electrical and thermal efficient devices, depending on the geographical position and environmental and weather conditions of the facility [7]. In

the 1970s, the first PV/T technologies began to emerge and be studied by several researchers around the world to improve their overall performances through innovative design [3]. The integration of these systems in buildings and their use in various weather situations have been the subject of research in recent years, with many leading publications on this topic. A study was conducted to assess the performance of integrated PV/T (BIPV/T) systems relative to PV (BIPV) systems in the context of New Delhi, India [7], and for the analysis of different types of PV cells: monocrystalline and amorphous. It was found that while the former is more efficient, the latter is more economical in the regional context. A further study [8] compares the performance of PV/T panels in Athens, Munich and Dundee and, as expected by the authors, the most promising and favorable conditions are in Athens [1].

Herrando et al. [9] conducted studies analyzing the use of hybrid PV/T technologies on a university campus for winter heating, summer cooling, and electricity generation. Gagliano et al. [10] have performed comparison of performances between solar thermal modules combined with photovoltaics and small PV/T system used in buildings. The module consists of a PV connected to a serpentine heat exchanger on the back. The authors opted for TRNSYS software as a simulation tool. They found that the combination of these two different technologies can improve the energy production of the system by up to 8.5% compared to conventional PV and thermal modules [11]. Khordehghah et al. [12] have attempted to do a much more thorough examination of the domestic water heating potential for a hybrid PV/T installation in the UK.

Shoeibi et al. [13] analyzed the performance of a finned solar photovoltaic/thermal air dryer with the use of a compound parabolic concentrator. The results showed that the CO<sub>2</sub> mitigation of the system using 24, 16, and 8 fins improved by 35.1%, 22.8%, and 10.7%, respectively. In addition, the electrical and thermal efficiencies of the solar photovoltaic/thermal air dryer using 24 fins were improved by 28.7% and 30.6%, compared to those without fins. Jouhara et al. [14] experimented with a PV/T hybrid collector installed on the roof of a single-family home. To make the heat transfer more efficient, they installed a multi-channel flat plate heat exchanger combined with the PV module. Their results are very relevant because they found that with the analyzed technology, an increase in electrical efficiency up to 15% is observed compared to conventional and uncooled PV systems. They also proved its performance and efficiency as an alternative system for water heating. Bombarde et al. [15] made an experimental comparison of the performance of PV/T hybrid systems with roller absorbers on the back of the collector, with and without thermal insulation. They found that with this type of heat exchanger, the thermal efficiency can be increased by about 10% compared to a PV/T collector with plate and tube heat exchanger. During this study, the authors observed a slight increase in the electricity produced.

Shoeibi et al. [16] investigated the influence of PV/T waste heat on water productivity and power generation of solar stills using heat pipes and a thermoelectric generator. The results showed that the highest hourly energy production of the solar panel of the conventional solar distiller (CSS), solar distiller by water cooling and thermoelectric generators (SS-WT), solar distiller by heat pipes (SS-HP) and solar distiller by heat pipes, water cooling and thermoelectric generators (SS-HP-WT) was about 68 W, 69 W, 73 W, and 75 W, respectively.

Thus, it turns out that hybrid PV/T systems have several performance advantages over other solar thermal and photovoltaic power generation sources. On the one hand, they allow the use of waste heat in the heating (or pre-heating) of domestic hot water while improving the efficiency of the photovoltaic cells which are thus cooled. On the other hand, the combination of photovoltaic modules and thermal collectors in one piece allows for better utilization of the available sun-exposed surfaces while saving on costs related to installation, transportation, and maintenance by implementing a single device instead of two separate ones [17].

While Africa represents 17% of the world's population, the continent accounts for only 4% of global energy supply [18]. In 2018, sub-Saharan Africa had an electrification rate of

45%, with frequent power outages and economic losses. This and many other conditions have hindered any development of industrial growth on the continent. In addition, the continent has the most abundant solar resources in the world but accounts for less than 1% of the world's installed solar PV capacity. Solar energy resources provide the opportunity to offer decentralized (and off-grid) solutions for remote infrastructure. The number of people who have accessed electricity through solar home systems in sub-Saharan Africa has increased from two million in 2016 to about five million in 2018 [18]. This shows that with adequate policies, solar energy could become one of the main resources to fill the continent's energy deficits. As a result, more research on solar technologies, such as PV/T, on the continent is needed to enable stakeholders to make informed decisions [19].

The few studies on PV/T technology in Africa in the literature were based on certain climates specific to North Africa [20,21] and the South Africa [22,23] sub-regions. In West Africa, some researchers have done studies on solar technology separately using solar thermal systems or solar PV, with very little evidence of studies on the performance of combined technology (PV/T) in the literature [24–26].

In any case, this little literature that can be found in these different countries or regions of the continent leaves nothing less than a very large void on a very large part of southeast Africa including the Indian Ocean region, of which the Comoros archipelago is part. The latter suffers from a lasting energy problem throughout the national territory marked by frequent power cuts sometimes caused by mechanical problems and maintenance within society, a lack of financial support from SONELEC, and finally problems of a social, political, geographical, economic nature, etc. This tends to have negative effects on all development projects, and clearly represents a danger to socio-economic development [27]. A few studies deal with this issue for the archipelago based on the energy mix as a solution for energy autonomy throughout the territory [28,29]. However, very few researchers have paid attention to a study on hybrid PV/T systems to meet the energy needs of the archipelago's inhabitants.

The present study aims to propose a feasible solution using existing innovative systems to meet both the demand for electricity at a lower cost and to satisfy the demand for domestic hot water for heating in households. The implementation of the system could not only be conducive to the individual but also contribute to the environment for low carbon emissions. This research work is expected to provide useful information on hybrid PV/T systems in rural home applications, which is quite instructive for other African countries in general and those in the Indian Ocean with a similar domestic energy consumption structure.

In this paper, the authors investigate the potential benefits of using PV/T technology in a tropical climate such as the Comoros Islands, which have never been studied. These performances are then compared to the performances obtained in the Mediterranean and continental climates typical of Europe, where this technology is more and more used thanks to a more favorable economic situation. The three sites chosen for the comparative study were Koua (Comoros, tropical climate, S 11°24' E 43°20'), Marseille (France, Mediterranean climate, N 43°17' E 5°22'), and Longwy (France, continental climate, N 49°30' E 5°46'). The objective of this research is to propose in a tropical and insular African country such as the Comoros a simple and effective method that could be undertaken by both government institutions and individuals to get out of the total dependence on diesel and the recurrent problems of power supply and load shedding. This will give us valuable information on the viability and usefulness of PV/T hybrid collectors as an alternative energy source for the supply of hot water and electricity in an a priori favorable climate.

## 2. Materials and Methods

### 2.1. PV/T System Design and Description

Figure 1 sketches the electrical and thermal system under study. The studied system mainly consists of PV/T panels with a surface of 12 m<sup>2</sup>, a water tank with a volume capacity of 200 L with auxiliary heating, water pump, a solar charge controller, and a storage battery.

Solar photovoltaic panels integrate a water heat exchanger that recovers heat and feeds the hot water storage tank. Therefore, energy losses are reduced and the heat recovery reduces the temperature rise of the photovoltaic cells and thus improves their electrical efficiency.

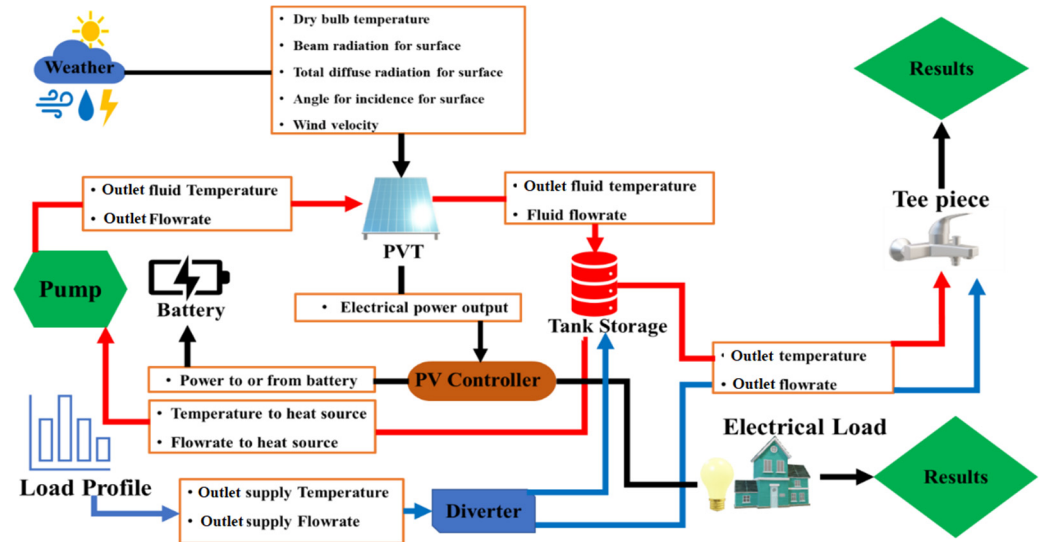

Figure 1. Schematic diagram of the PVT system.

The fluid is circulated in the solar panels as soon as the temperature at the outlet of the panels is higher than the upper temperature of the hot water tank. An auxiliary heater is only switched on when the upper temperature of the storage tank is below 60 °C without exceeding 90 °C. The electrical energy produced by the photovoltaic cells is sent to the controller which manages the distribution of electrical energy to meet demand, charge the batteries or, if not, inject into the electrical network.

## 2.2. Modeling Approach

### 2.2.1. Thermal Model of the PV/T Panel

The PV/T panels used in the current simulation work are 1.5 m long and 1 m wide. They are composed successively by:

1. a layer of photovoltaic cells covered by a very thin glass and whose surface temperature is assumed to be equal to the temperature of the photovoltaic cells.
2. a substrate on which the PV cells are glued with a thermal resistance of 0.036 Km<sup>2</sup>/W.
3. a copper absorption plate with a thickness of 0.5 mm the tubes in which the water circulates are welded lengthwise. The tubes have a diameter of 1 cm and are spaced at 10 cm.
4. a layer of insulation with a thermal resistance of 10.8 Km<sup>2</sup>/W.

The heat transfer is modeled in 1D. The heat flow absorbed by the metal plate is largely conducted to the tubes according to the monodirectional model of a rectangular fin in steady state with a symmetry boundary condition at mid distance between the tubes [30]. The heat conducted to the fluid is absorbed by the latter thanks to the heat transfer by convection which the coefficient is calculated internally by the Type 560 model. This coefficient is primarily a function of the flow rate of the fluid in each tube and to a lesser extent a function of the average temperature between the inlet and outlet of the tubes. Figure 2 illustrates the different energy flows modeled. The absorbed part of the solar radiation is partly transformed into electrical energy. The other part is partially absorbed by the water circulating in the tubes. The insulation layer drastically limits the heat loss at the back of the panel.

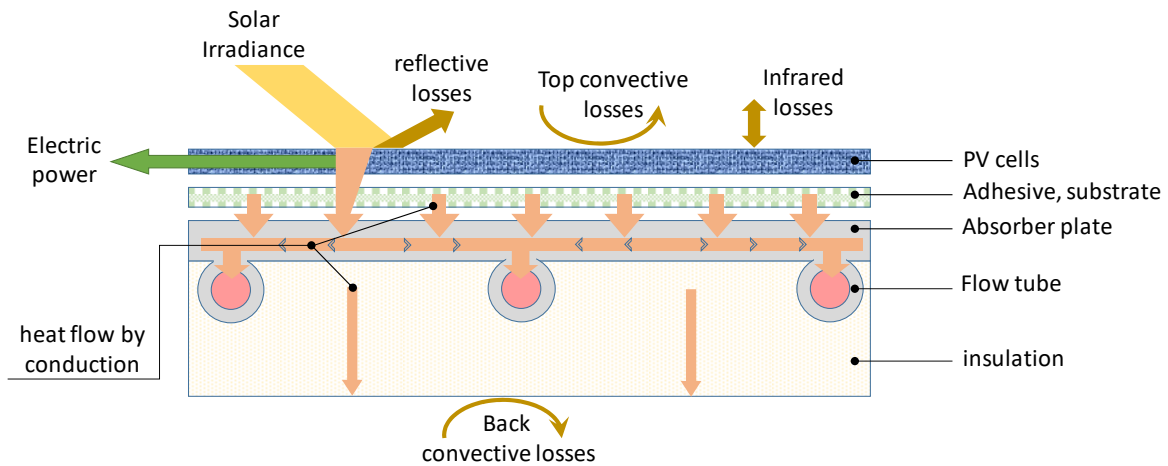

**Figure 2.** Cross-sectional diagram of the PV/T energy transfer process.

The solar irradiance absorbed by the solar collector and not transformed into electricity, noted here  $S$ , is dissipated by convection, infrared radiation, and by conduction. The energy balance at the surface of the panel is therefore given by the following conservative equation [31]:

$$S - h_{outer}(T_{pv} - T_{amb}) - h_{rad}(T_{pv} - T_{sky}) - \frac{(T_{pv} - T_{abs})}{R_T} = 0 \tag{1}$$

where  $S$  ( $W/m^2$ ) accounts for the absorbed solar radiation minus the PV power production:

$$S = (\tau\alpha)_n IAM G_T (1 - \eta_{PV}) \tag{2}$$

where  $(\tau\alpha)_n$  is the normal transmittance-absorptance product for the solar collector,  $IAM$  an incidence angle modifier,  $G_T$  the solar irradiance and  $\eta_{PV}$  the PV cell efficiency. The second, third, and fourth terms of the Equation (1) represent respectively the heat loss by convection and infrared radiation at the surface and the heat flux conducted to the absorption plate. In this equation,  $T_{pv}$ ,  $T_{amb}$ ,  $T_{sky}$ , and  $T_{abs}$  are respectively the temperatures of the PV cells, ambient air, fictive sky, and absorption plate temperatures.  $R_T$  is the resistance to heat transfer from the PV cells to the absorber

Plate and  $h_{rad}$  the radiative heat transfer coefficient from the top of the collector to the sky. The use of the latter allows the linearization, for iterative calculations, of the long wavelength radiative exchanges emanating from the Stephan Boltzmann equation.

The power generated by the PV cells is calculated by taking into account the effective operational PV efficiency  $\eta_{PV}$  which depends on the received solar irradiation and the temperature of the PV cells as follows:

$$\eta_{PV} = \eta_{nominal} X_{celltemp} X_{Radiation} \tag{3}$$

With:

$$X_{celltemp} = 1 + Eff_T (T_{pv} - T_{ref}) \tag{4}$$

$$X_{Radiation} = 1 + Eff_G (G_T - G_{ref}) \tag{5}$$

where  $\eta_{nominal}$  is the nominal efficiency at  $T_{ref} = 25\text{ }^\circ\text{C}$  and  $G_{ref} = 1000\text{ W/m}^2$ ,  $X_{celltemp}$  and  $X_{radiation}$  are modifying multipliers for cells temperature and solar radiation, respectively ( $Eff_T = -0.005\text{ K}^{-1}$  and  $Eff_G = 2.5 \times 10^{-5}\text{ K}^{-1}$ ).

For more details on the thermal model of the PV/T panel used, see reference [32].

The useful heat rate flow recovered by the fluid and the thermal efficiency are given as the following:

$$Q = \dot{m}C_p(T_f - T_i) \quad (6)$$

$$\eta_{th} = 100\% \times \frac{\dot{m}C_p(T_f - T_i)}{Area.G_T} \quad (7)$$

where  $T_f$  and  $T_i$  are respectively the outlet and inlet temperatures of the fluid.

Since the panel produces heat and electricity simultaneously, we can define a total efficiency as the ratio between the sum of the produced energies and the received solar energy

$$\eta_{tot} = \eta_{pv} + \eta_{th} \quad (8)$$

### 2.2.2. Numerical Simulation

The numerical simulation of the studied system was carried out using the dynamic thermal simulation tool Trnsys. The latter has the advantage of a modular graphical interface where different unit models can be combined in order to simulate the operation of a complex thermal system.

In order to accomplish the simulation, we have used several models available mainly in the standard and TESS libraries of this software. The main components considered in the simulation are:

1. PVT solar collectors whose thermal model is described above,
2. a pump that is started as soon as the weather conditions are favorable for heating water to a temperature higher than that of the hot water tank,
3. a stratified hot water tank equipped with an auxiliary heater to meet the hot water demand when the solar energy collected is not sufficient,
4. components to manage the mixing of the hot water available in the tank at 60 °C and the cold water whose temperature varies during the year to meet the need for domestic hot water at 45 °C,
5. for the electrical part, the system includes a battery and a charge controller. The latter ensures that the electrical energy produced is, in order, either consumed, stored or injected into the network.

Figure 3 shows the simulator developed on Trnsys and Table 1 summarizes the main characteristics of the simulated system.

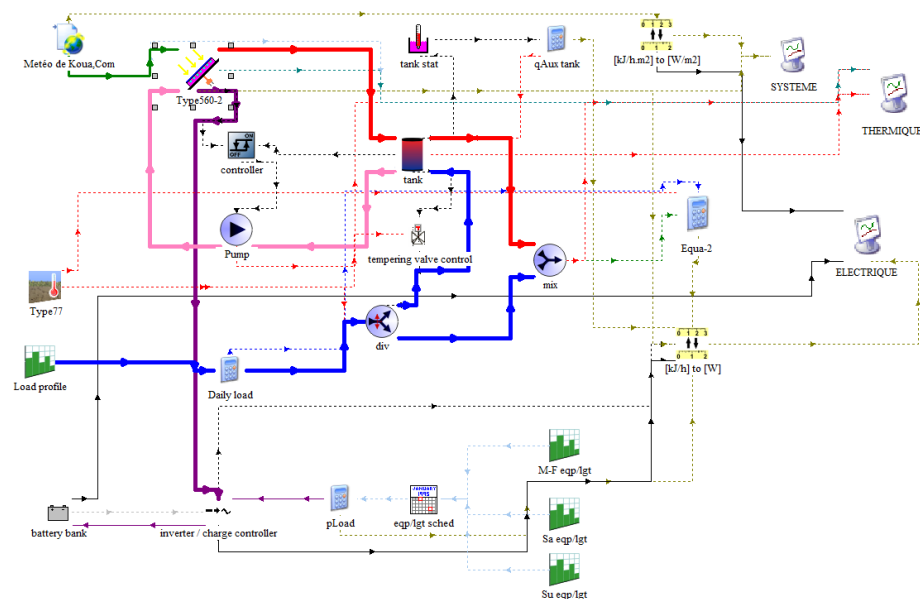

Figure 3. PV/T system simulator developed in TRNSYS.



**Table 1.** summary of the main features of the PV/T collectors.

Name	Value
Collector length	1.5 m
Collector width	1 m
Number of PV/T collectors	8
Absorber plate thickness	1 mm
Absorber thermal conductivity	385 Wm <sup>-1</sup> K <sup>-1</sup>
Spacing of tubes	10 cm
Tube diameter	1 cm
Insulation resistance	11
PV/T surface reflectance	0.15
PV/T surface emissivity	0.9
Monocrystalline Cell efficiency at reference conditions	0.12
Capacity of the battery	200 Wh
Slope of the collector facing the equator	Koua: 22°; Marseille: 53°; Longwy: 59°
Hot water tank volume	200 L

### 2.3. Case Studies with Comparative Scenarios

#### 2.3.1. Weather Conditions

In order to show the particular interest of the use of PVT in the Comoros, we proposed to quantify its expected performance for a typical household in this particular climatic context and then compare it to the performance achieved in typical Mediterranean and continental climates in Europe, where this technology is increasingly used thanks to a more favorable economic situation. For this, three locations were selected for the comparative study: Koua in Ngazidja which enjoys a tropical climate, Marseille city with its Mediterranean climate, and Longwy city with its continental climate.

Figure 4 illustrate the typical main climatic conditions in the three chosen locations. Mean values of solar irradiance and ambient air temperature are plotted and compared for three locations. It should be noted that the differences in temperature and solar radiation levels between the summer and winter seasons are much less pronounced in Comoros than in France. The climate of the Comoros Islands is tropical, with a hot and rainy season from December to April, when the northwest monsoon prevails, and a relatively cool and dry season from May to November, in which the southeast trade winds predominate. The average daily temperature rises from about 28 °C in the warmest period (January to April) to around 25 °C in the coolest months (July, August, and September). In the Comoros, the summer period begins from December to February, but the winter period is from June to August. Solar radiation in Koua varies over the year generally less than in the two French cities (apart from exceptionally high solar irradiance in September, the level of irradiance at Koua varies little overall).

To facilitate the comparison, we have chosen an equal sizing of the different components of the PVT system used to meet the same needs in terms of electrical energy and domestic hot water. The only differences, in addition to the climatic conditions imposed, concern the optimal slope given to the solar collector in the three cities according to their latitudes as well as the cold-water temperature calculated from the average seasonal evolution of the temperature in each location.

#### 2.3.2. DHW and Electricity Needs

DHW (domestic hot water) and electricity needs of a typical Comorian household were chosen in this work in order to assess the relevance of use of PVT technology in a subtropical climate. Thus, the choice that was made for the comparisons is to set the energy requirements and evaluate the ability of the system to meet the same load when subjected to different climates. In order to set a safe and reliable daily profile for energy requirements, it is necessary to consider several parameters, mainly the number of inhabitants, appliances, ambient conditions, and seasonal variations. Hence, maximal DHW needs are estimated at

50 L at 50 °C per day per person. The volume of the hot water storage tank is be able to cover 1.5 times the daily needs.

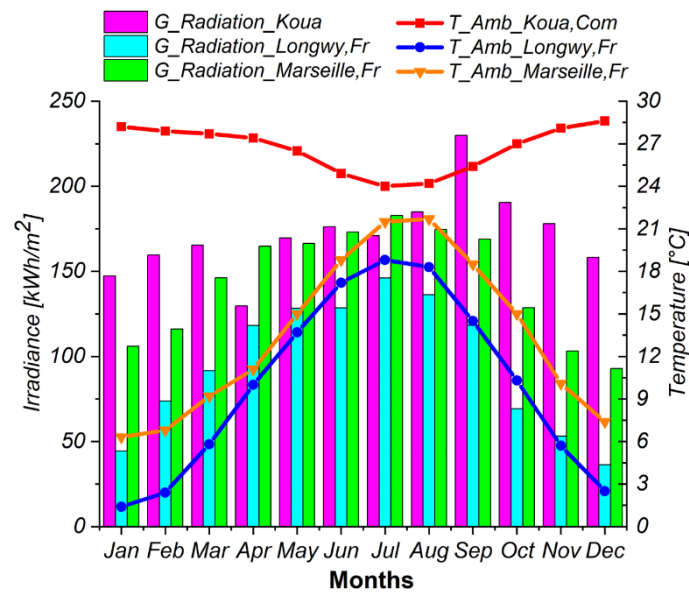

Figure 4. Mean values of solar radiation and ambient temperature in Koua, Marseille, and Longwy cities.

In this study, the temperature level for the DHW has been set at 45 °C, while cold water varies depending on the temperature of the soil relative to the buried pipes, the average temperature of the Earth’s surface, and the amplitude. The electricity and DHW requirements considered in the study follow a weekly scenario with a difference between weekdays and weekends. Figure 5 illustrates the daily profile for weekdays both for DHW and electricity needs. These are covered either directly by the power produced by the PV panels or by the battery or, failing that, by the grid.

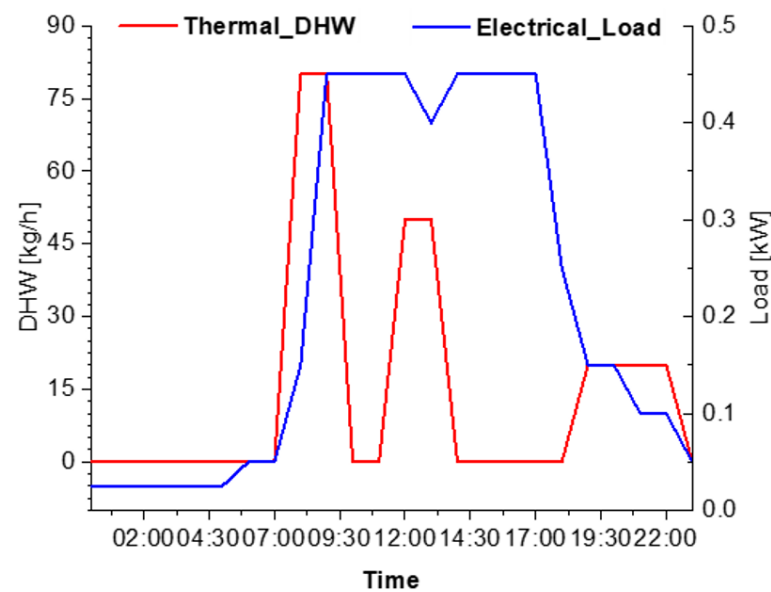

Figure 5. Daily profile of thermal and electrical load.

### 3. Results and Discussion

One of the most influential parameters in terms of heat recovery efficiency is the flow rate of the operating fluid. In order to determine the optimal operating flow rate, a



parametric study was carried out to investigate the dependence of the thermal efficiency of the system on the operating flow rate. Figure 6 shows a comparison of the variations of the thermal efficiencies obtained for five imposed flow rates. As we can see, the thermal efficiency increases with the fluid flow rate with an asymptotic maximum. Indeed, from 200 L/h the gain in thermal efficiency is minimal and the increase of the flow rate would increase the pressure losses and thus the consumption of the pump without bringing a notable improvement of the thermal efficiency of the PVT collector. In the following, the operating flow rate will be set at 200 L/h.

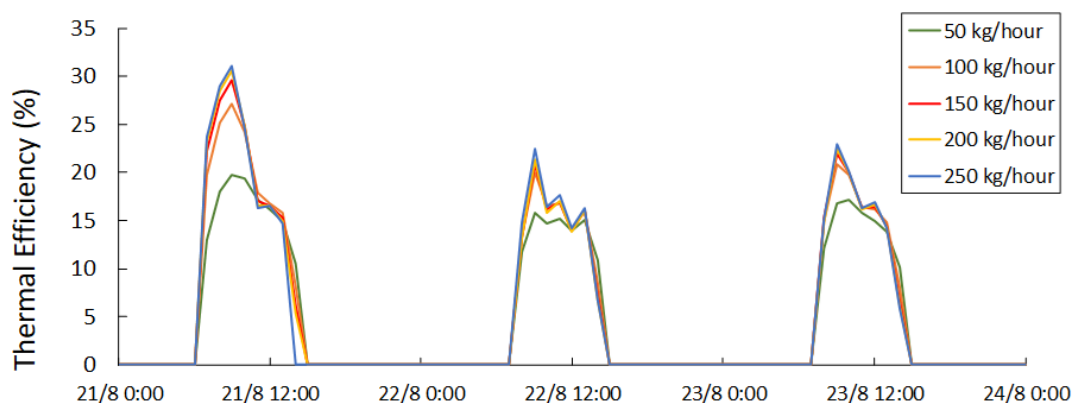

**Figure 6.** Thermal efficiency variations with various operating fluid flow rates.

### 3.1. Hourly Analysis of System Operation

Annual simulations were carried out for the three climates using a time step of 1 h. Comparison is made in two different periods during three days of winter (21 to 23 January) and summer (21 to 23 August). Figures 7 and 8 illustrate typical results obtained with the simulator for three typical days in each season.

During the three winter days illustrated, as the electrical production depends directly on the solar radiation, the electrical production in Koua is clearly higher than in France, especially in comparison with Longwy (up to 0.81 kW in Koua, about 0.4 kW at Marseille and only about 0.2 kW at Longwy). Indeed, we observe, during these three days, there was no need to connect to the grid in Koua since the solar energy produced perfectly meets the demand with a battery SOC varying between 20% and 84%. In contrast, the battery in Longwy remains almost flat with only one peak not exceeding a SOC of 14% which is discharged immediately (see Figure 7, left). It is worth noting that during the day, the system stores the excess energy in the batteries and uses it at night and non-sunny periods.

The equivalent performance of the PV system in Koua between the summer and winter seasons can be explained by the high level as well as the relatively low annual variations of solar irradiance. Indeed, Figure 7, right shows, over the three-day period illustrated, that the electrical performance of the system improves in the two French cities with more battery charge and discharge cycles (respectively positive and negative pfromBatt, which represents the stored or used power of the battery). Moreover, we can observe for these same cities power used from the electrical grid is half as great during these summer days.

Figure 8 illustrates, like Figure 7, the variations of certain quantities in the three cities during three days of winter (left) and three days of summer (right). On each graph are plotted on the left-hand axis in the following order: the temperature of the water at the inlet to the collectors, the temperature of the water at the outlet from the collectors, the temperature of the water at the outlet from the hot-water tank, and the temperature of use, which is set at 45 °C. On the left-hand axis, the following are plotted in order: the mass flow rate in the collectors set in motion by the pump and the DHW consumption flow rate given by the scenario considered in Figure 5. It is important to highlight that the temperature of the water at the outlet of the collector and the temperature of use plotted only have a real

meaning when the flow of water in the collectors and the flow of hot water consumed are not zero.

It can be seen on this figure that the pump is only started when the calculation gives a temperature at the outlet of the collectors higher than the temperature at the inlet of these. The latter is equal to the temperature at the bottom of the hot water tank. This allows the production of hot water by solar energy and its storage in the tank. We can also see that in the absence of favorable weather conditions, the use of stored hot water reduces the tank outlet temperature because it is immediately replaced by cold water.

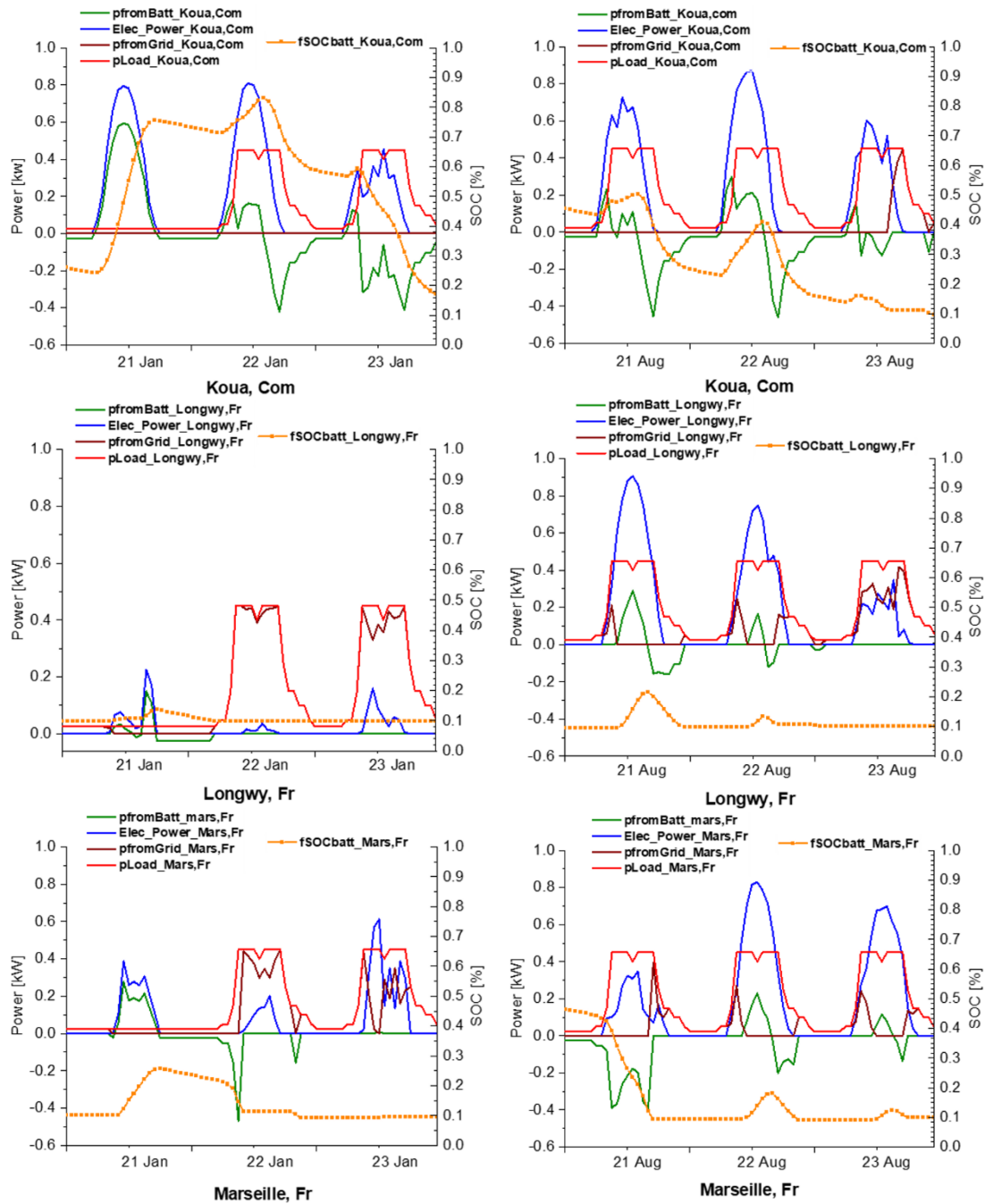
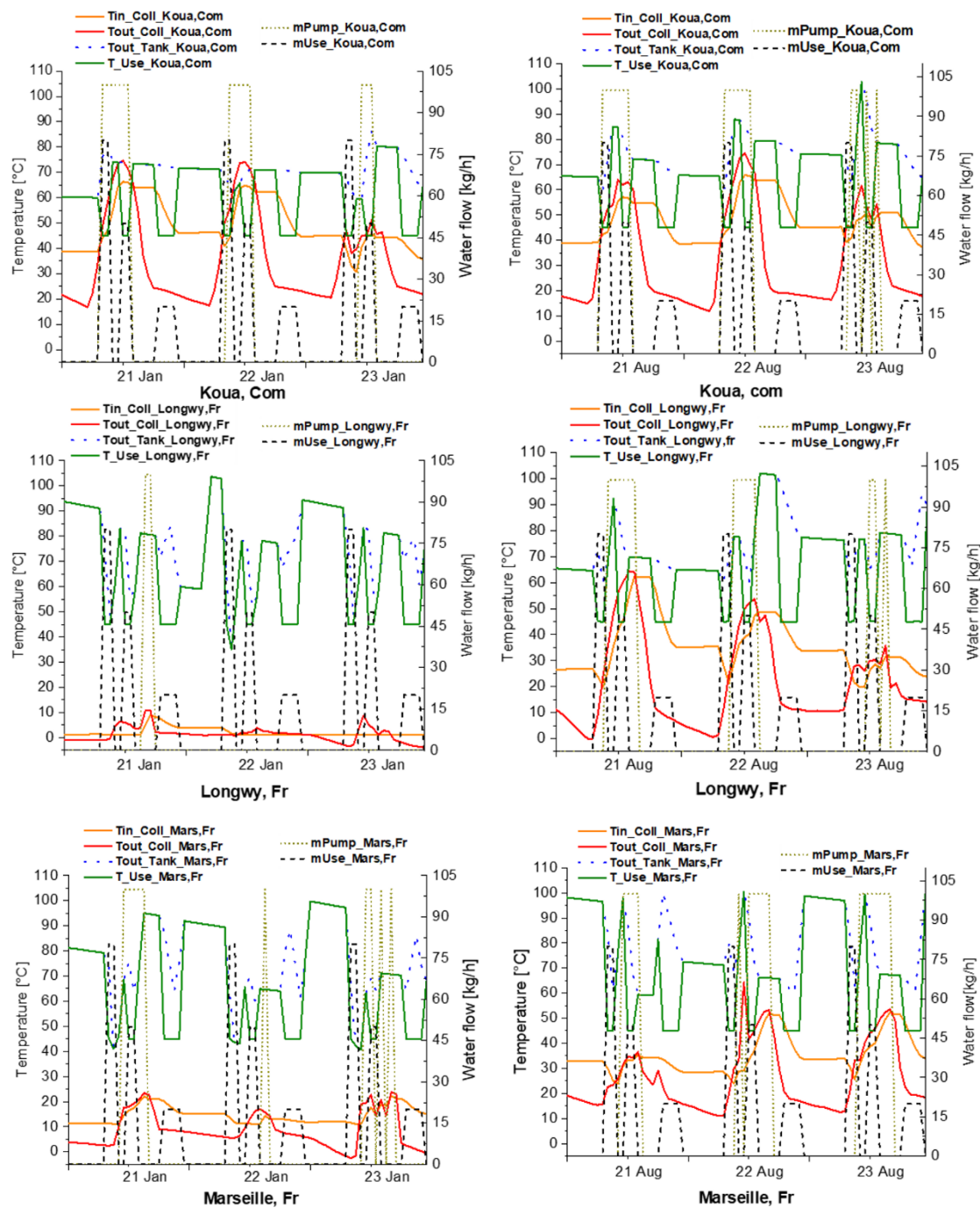

Figure 7. Electrical power produced, consumed, or stored during three typical days in January and August at Koua, Marseille, and Longwy.



**Figure 8.** Temperature variations across the PV/T collector and hot water tank and sequences of pump operation and DWH use at Koua, Marseille, and Longwy.

Finally, Figure 8 shows that the start-up of the pump (synonymous with solar DWH production) is more frequent and lasts longer during the summer, especially for the two French cities where the sun is scarce during the winter. In Koua, in contrast, solar DWH production is just as interesting in summer as in winter.

Although the cooling of the photovoltaic cells by the fluid allows only a modest improvement of their electrical efficiency, the PV/T system allows to recover a significant part of the fatal heat to heat the domestic water. This results in a total efficiency of up to 40% when considering the sum of the electrical and thermal power produced in proportion to the solar radiation received by the collectors according to the Equation (8) (cf. Figure 9).

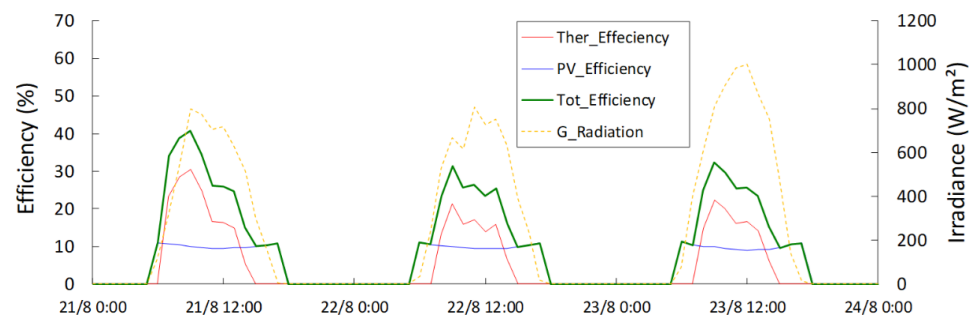

**Figure 9.** Thermal, electrical, and total efficiencies of the PVT system in Koua during three typical summer days.

### 3.2. Overall Performance Comparison

The useful thermal and electrical energy produced by the PV/T plant during the year were integrated monthly and are presented in Figures 10 and 11. Figure 10 allows the comparison of the system performance in the three considered climates. We can see that the use of this technology allows a fairly regular production throughout the year in a country with a tropical climate such as the Comoros. Indeed, apart from September, electric and thermal power produced in Koua vary between 105 and 170 kWh/month while in the two French cities, the production varies twofold between winter and summer. The maximum solar energy production occurs in the summer period due to the maximum solar radiation during this period. In the Union of the Comoros, in September, there is a maximum production of thermal and electrical energy respectively in the order of 207.5 and 202.7 kWh/month. The installation in Longwy produces a maximum of 133.67 kWh of thermal energy and 131.37 kWh of electrical energy per month. As for the city of Marseille, it produces a maximum of 157.51 kWh/month of electrical energy against 175 kWh/month of thermal energy.

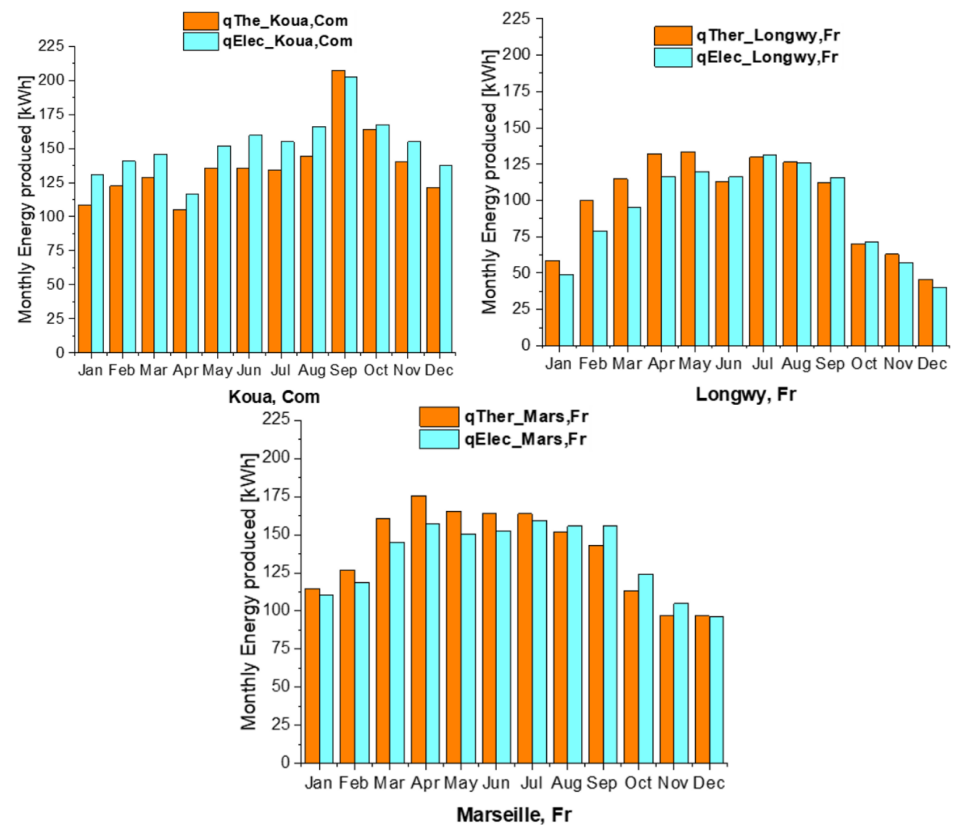

**Figure 10.** Monthly production of thermal and electrical energy in Koua, Longwy, and Marseille.

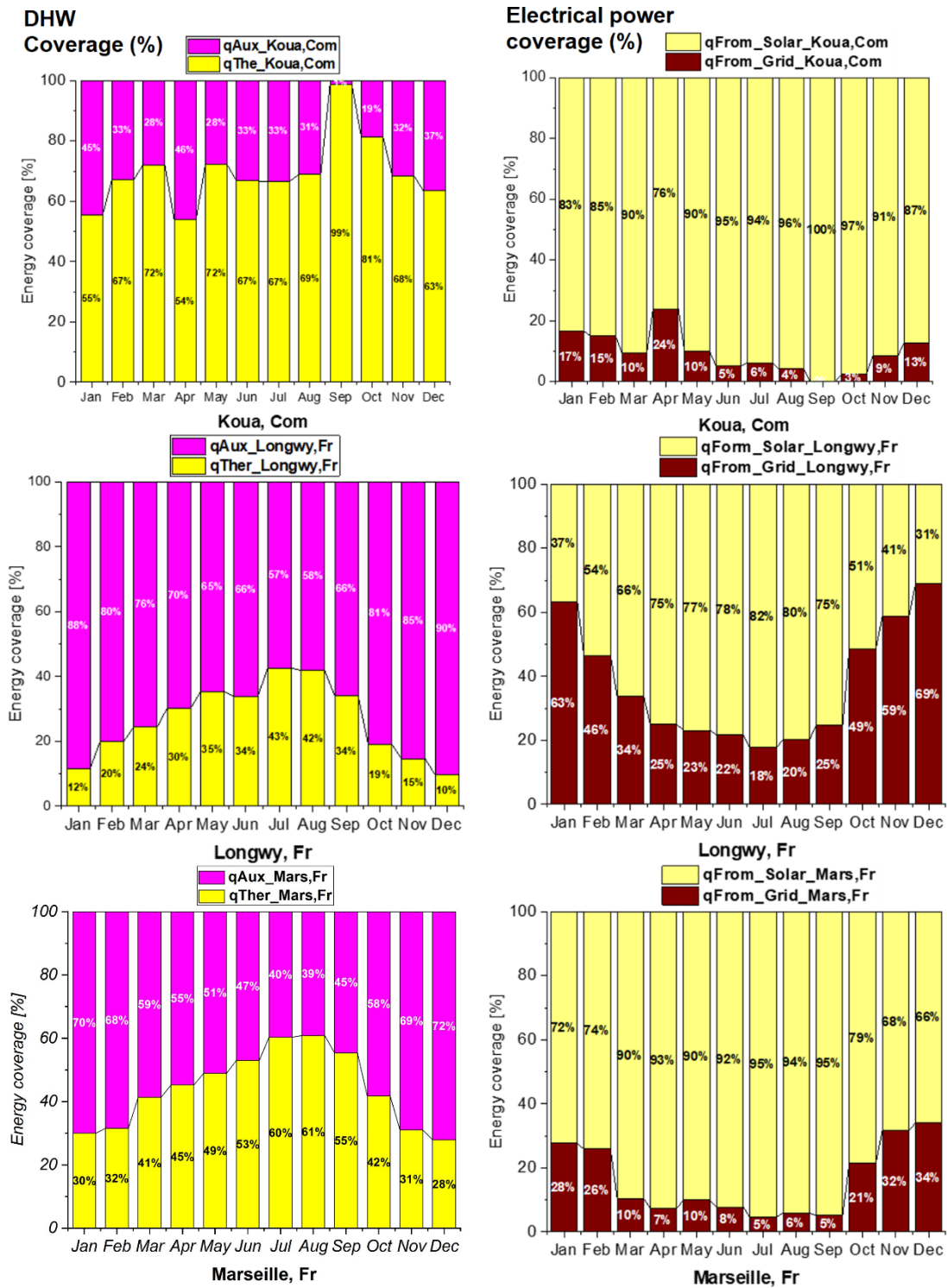

Figure 11. Solar coverage for DHW and electricity loads.

Apart from the comparison of the useful thermal and electrical power produced, it is essential to compare the solar coverage rate between these three sites, i.e., the proportion of electricity and hot water needs covered by the PV/T system. Figure 11 illustrates the solar coverage rate for electricity and DHW in the three cities month by month. In this figure, the solar coverage rates are shown in yellow. This figure shows that solar energy covers, all year round, about 70% of the DHW needs in Koua, while it only covers 10% to 40% of the needs in France depending on the season (10% in winter and 40% in summer). As for

the electrical needs, the PV/T installation covers about 80% of the charge in summer in Longwy against nearly 95% in Koua and in Marseille. On the other hand, in winter, while the rate of electrical coverage drops to 30% in Longwy, it is maintained in Koua between 80% and 90% (vs. 70 in Marseille).

#### 4. Conclusions

The present study assesses the performance of a hybrid photovoltaic and thermal collector system to meet the energy needs of isolated Comorian households. A numerical simulation of a complex system modeling the heat transfer in tubular collectors with absorption plate has been performed. The modeled system includes the management of the thermal and electrical storage of the produced energy. The results quantify the performance of the PV/T system in Comoros archipelago and compare it to typical French/European climates. Hourly analysis of the system operation showed that the produced electrical power perfectly meets the demand with a battery SOC mainly varying between 20% and 80%. Moreover, it showed solar DHW production is more frequent and is as interesting in summer as in winter in Comoros unlike in France where it is only interesting in summer. Therefore, considering the sum of electrical and thermal energy produced in proportion to the solar radiation, the use of a PV/T system allows to operate with a total efficiency up to 40% during the whole year in Comoros while the system approaches this value only in summer in France. In fact, a fairly regular electric and thermal power production throughout the year in Comoros while in the two French cities, the production varies twofold between winter and summer. Finally, the results show that the hybrid solar system covers 70% of the DHW needs in Koua while it only covers 10% to 40% of the needs in France depending on the season. It also covers 80% of the electrical demand in Comoros all year long while it covers only 20% to 30% of the demand in France.

In other aspects, this work demonstrates the particular interest of the Comoros to develop the use of this solar technology to meet the energy needs of the population in order to get out of the total dependence on diesel fuel, which is currently the only source of energy in the archipelago. It can be concluded from this study that the Comorian market and more generally the sub-Saharan market on PVT systems has a good potential for development as long as the economic situation allows it. A techno-economic and a study of the performance of the system would be a very interesting further study, including the consideration of environmental impact and greenhouse gas emissions.

**Author Contributions:** F.M., R.D., M.A.K. and M.E.G. all contributed to the conceptualization and realization of this work. The methodology and implementation of the simulator was carried out by F.M. and R.D. All authors have read and agreed to the published version of the manuscript.

**Funding:** This work was supported by national CPER “ENERBATIN Bâtiment intelligent” program and French government through PHC projects: MAGHREB 41557PF and Tassili 46048RB.

**Conflicts of Interest:** The authors declare no conflict of interest.

#### Nomenclature

$T$	Temperature	(°C)
$H$	Efficiency	(%)
$K$	Thermal conductivity	(W/mK)
$\Delta$	Thickness	(m)
$A_{ren}$	Collector area	(m <sup>2</sup> )
$\dot{m}$	Mass flow rate	(L/h)
$\beta_r$	Temperature coefficient	(%/K)
$\alpha$	Absorptivity	(-)
$U$	Heat transfer coefficient	(W/(m <sup>2</sup> K))
$h$	Penalty factor	(-)
$T_{sky}$	The temperature of the sky	(°C)
$G$	Daily solar irradiation	(W/m <sup>2</sup> )
$T_f$ et $T_i$	Fluid outlet and inlet temperatures	(°C)



$\tau\alpha$	Transmittance-absorption product of solar collector	(-)
$IAM$	Incidence angle modifier	(-)
$C_p$	Specific heat	(J/kg K)
$q_{Ther}$	Thermal energy	(kWh)
$q_{Elec}$	Electrical energy	(kWh)
$q_{Aux}$	Auxiliary energy	(kWh)
STC	Standard test conditions	
DHW	Domestic hot water (English)	
ECS	Domestic hot water (French)	
TMY	Typical weather year	
PVT	Photovoltaic thermal	
PV	Photovoltaic	
ST	Solar thermal	

## References

- Barbu, M.; Darie, G.; Siroux, M. Analysis of a Residential Photovoltaic-Thermal (PVT) System in Two Similar Climate Conditions. *Energies* **2019**, *12*, 3595. [CrossRef]
- Baljic, S.S.S.; Chan, H.-Y.; Sopian, K. Review of Building Integrated Applications of Photovoltaic and Solar Thermal Systems. *J. Clean. Prod.* **2016**, *137*, 677–689. [CrossRef]
- Zondag, H.A. Flat-Plate PV-Thermal Collectors and Systems: A Review. *Renew. Sustain. Energy Rev.* **2008**, *12*, 891–959. [CrossRef]
- Chow, T.T.; He, W.; Ji, J. Hybrid Photovoltaic-Thermosyphon Water Heating System for Residential Application. *Sol. Energy* **2006**, *80*, 298–306. [CrossRef]
- Raghuraman, P. Analytical Predictions of Liquid and Air Photovoltaic/Thermal, Flat-Plate Collector Performance. *J. Sol. Energy Eng.* **1981**, *103*, 291–298. [CrossRef]
- Diwania, S.; Agrawal, S.; Siddiqui, A.S.; Singh, S. Photovoltaic-Thermal (PV/T) Technology: A Comprehensive Review on Applications and Its Advancement. *Int. J. Energy Environ. Eng.* **2020**, *11*, 33–54. [CrossRef]
- Agrawal, B.; Tiwari, G.N. Life Cycle Cost Assessment of Building Integrated Photovoltaic Thermal (BIPVT) Systems. *Energy Build.* **2010**, *42*, 1472–1481. [CrossRef]
- Axaopoulos, P.J.; Fylladitakis, E.D. Performance and Economic Evaluation of a Hybrid Photovoltaic/Thermal Solar System for Residential Applications. *Energy Build.* **2013**, *65*, 488–496. [CrossRef]
- Herrando, M.; Pantaleo, A.M.; Wang, K.; Markides, C.N. Solar Combined Cooling, Heating and Power Systems Based on Hybrid PVT, PV or Solar-Thermal Collectors for Building Applications. *Renew. Energy* **2019**, *143*, 637–647. [CrossRef]
- Gagliano, A.; Tina, G.M.; Aneli, S.; Nižetić, S. Comparative Assessments of the Performances of PV/T and Conventional Solar Plants. *J. Clean. Prod.* **2019**, *219*, 304–315. [CrossRef]
- Behzadi, A.; Arabkoohsar, A.; Yang, Y. Optimization and Dynamic Techno-Economic Analysis of a Novel PVT-Based Smart Building Energy System. *Appl. Therm. Eng.* **2020**, *181*, 115926. [CrossRef]
- Khordehghah, N.; Guichet, V.; Lester, S.P.; Jouhara, H. Computational Study and Experimental Validation of a Solar Photovoltaics and Thermal Technology. *Renew. Energy* **2019**, *143*, 1348–1356. [CrossRef]
- Shoeibi, S.; Kargarsharifabad, H.; Mirjalily, S.A.A.; Zargarzad, M. Performance Analysis of Finned Photovoltaic/Thermal Solar Air Dryer with Using a Compound Parabolic Concentrator. *Appl. Energy* **2021**, *304*, 117778. [CrossRef]
- Jouhara, H.; Milko, J.; Danielewicz, J.; Sayegh, M.A.; Szulgowska-Zgrzywa, M.; Ramos, J.B.; Lester, S.P. The Performance of a Novel Flat Heat Pipe Based Thermal and PV/T (Photovoltaic and Thermal Systems) Solar Collector That Can Be Used as an Energy-Active Building Envelope Material. *Energy* **2016**, *108*, 148–154. [CrossRef]
- Bombarda, P.; Di Marcobertardino, G.; Lucchini, A.; Leva, S.; Manzolini, G.; Molinaroli, L.; Pedranzini, F.; Simonetti, R. Thermal and Electric Performances of Roll-Bond Flat Plate Applied to Conventional PV Modules for Heat Recovery. *Appl. Therm. Eng.* **2016**, *105*, 304–313. [CrossRef]
- Shoeibi, S.; Saemian, M.; Khiadani, M.; Kargarsharifabad, H.; Ali Agha Mirjalily, S. Influence of PV/T Waste Heat on Water Productivity and Electricity Generation of Solar Stills Using Heat Pipes and Thermoelectric Generator: An Experimental Study and Environmental Analysis. *Energy Convers. Manag.* **2023**, *276*, 116504. [CrossRef]
- Brottier, L. Optimisation Biénergie d'un Panneau Solaire Multifonctionnel: Du Capteur Aux Installations in situ. Ph.D. Thesis, Université Paris-Saclay, Gif-sur-Yvette, France, 2019.
- Africa Energy Outlook 2019—Analysis. Available online: <https://www.iea.org/reports/africa-energy-outlook-2019> (accessed on 18 October 2022).
- Bissiri, M.; Moura, P.; Figueiredo, N.C.; Silva, P.P. Towards a Renewables-Based Future for West African States: A Review of Power Systems Planning Approaches. *Renew. Sustain. Energy Rev.* **2020**, *134*, 110019. [CrossRef]
- Hazami, M.; Riahi, A.; Mehdaoui, F.; Nouicer, O.; Farhat, A. Energetic and Exergetic Performances Analysis of a PV/T (Photovoltaic Thermal) Solar System Tested and Simulated under to Tunisian (North Africa) Climatic Conditions. *Energy* **2016**, *107*, 78–94. [CrossRef]

21. Slimani, M.E.A.; Amirat, M.; Kurucz, I.; Bahria, S.; Hamidat, A.; Chaouch, W.B. A Detailed Thermal-Electrical Model of Three Photovoltaic/Thermal (PV/T) Hybrid Air Collectors and Photovoltaic (PV) Module: Comparative Study under Algiers Climatic Conditions. *Energy Convers. Manag.* **2017**, *133*, 458–476. [[CrossRef](#)]
22. Siecker, J.; Kusakana, K.; Numbi, B.P. Optimal Switching Control of PV/T Systems with Energy Storage Using Forced Water Circulation: Case of South Africa. *J. Energy Storage* **2018**, *20*, 264–278. [[CrossRef](#)]
23. Oyieke, A.Y.; Inambao, F.L. Performance Characterisation of a Hybrid Flat-Plate Vacuum Insulated Photovoltaic/Thermal Solar Power Module in Subtropical Climate. *Int. J. Photoenergy* **2016**, *2016*, 6145127. [[CrossRef](#)]
24. Sawadogo, W.; Abiodun, B.J.; Okogbue, E.C. Impacts of Global Warming on Photovoltaic Power Generation over West Africa. *Renew. Energy* **2020**, *151*, 263–277. [[CrossRef](#)]
25. Meunier, S.; Heinrich, M.; Quéval, L.; Cherni, J.A.; Vido, L.; Darga, A.; Dessante, P.; Multon, B.; Kitanidis, P.K.; Marchand, C. A Validated Model of a Photovoltaic Water Pumping System for Off-Grid Rural Communities. *Appl. Energy* **2019**, *241*, 580–591. [[CrossRef](#)]
26. Akinyele, D.; Babatunde, O.; Monyei, C.; Olatomiwa, L.; Okediji, A.; Ighravwe, D.; Abiodun, O.; Onasanya, M.; Temikotan, K. Possibility of Solar Thermal Power Generation Technologies in Nigeria: Challenges and Policy Directions. *Renew. Energy Focus* **2019**, *29*, 24–41. [[CrossRef](#)]
27. Aboudou, K.M.; Ganaoui, M.E. Design of a Hybrid System for Rural Area Electricity Supply in Comoros. *J. Power Energy Eng.* **2019**, *7*, 59–78. [[CrossRef](#)]
28. Maoulida, F.; Rabah, D.; Mohammed, E.G.; Aboudou Mohamed, K. PV-Wind-Diesel System for Energy Supply on Remote Area Applied for Telecommunication Towers in Comoros. *Open J. Energy Effic.* **2021**, *10*, 50–72. [[CrossRef](#)]
29. Maoulida, F.; Aboudou, K.; Djedjig, R.; El-Ganaoui, M. Feasibility Study for a Hybrid Power Plant (PV-Wind-Diesel-Storage) Connected to the Electricity Grid. *fdmp* **2022**, *18*, 1607. [[CrossRef](#)]
30. Incropera, F.P.; DeWitt, D.P.; Bergman, T.L.; Lavine, A.S. *Fundamentals of Heat and Mass Transfer 5th Edition with IHT2.0/FEHT with Users Guides*; Wiley: Hoboken, NJ, USA, 2001; ISBN 978-0-471-20448-0.
31. Duffie, J.A.; Beckman, W.A. *Solar Engineering of Thermal Processes*; John Wiley & Sons: Hoboken, NJ, USA, 2013.
32. Thornton, J.W.; Bradley, D.E.; McDowell, T.P.; Blair, N.J.; Duffy, M.J.; LaHam, N.D.; Naik, A.V. TESSLibs 17 Component Libraries for the TRNSYS Simulation Environment. HVAC Library Mathematical Reference. 2014. Available online: <http://web.mit.edu/parmstr/Public/TRNSYS/04-MathematicalReference.pdf> (accessed on 20 December 2022).

**Disclaimer/Publisher’s Note:** The statements, opinions and data contained in all publications are solely those of the individual author(s) and contributor(s) and not of MDPI and/or the editor(s). MDPI and/or the editor(s) disclaim responsibility for any injury to people or property resulting from any ideas, methods, instructions or products referred to in the content.