

Article

Insights into the Potential Effects of Micro(nano)plastic-Containing Nanoparticles in the Environment

Carlos Fito López ^{1,*} , Beatriz Díaz Soler ², Ana Guillem-Amat ¹  and Oscar Andreu Sánchez ^{3,*} 

¹ ITENE, Technological Institute of Packaging, Transport and Logistics, 46980 Paterna, Spain; anaguam@gmail.com

² Department of Building Construction, University of Granada, 18010 Granada, Spain; atriz@correo.ugr.es

³ Department of Vegetal Biology, Faculty of Pharmacy, University of València, C/Vicent Andrés Estellés, s/n, 46100 Valencia, Spain

* Correspondence: carlos.fito@itene.com (C.F.L.); oscar.andreu@uv.es (O.A.S.); Tel.: +34-647521544 (C.F.L.)

Abstract: Micro(nano)plastics (MNP) can be generated from a variety of sources, including the breakdown of larger plastic items, the abrasion of synthetic textiles, and the fragmentation of plastic waste. These particles can become airborne and be transported by wind, potentially leading to their presence in the atmosphere. Due to their widespread applications, ZnO particles at the nanometer range have attractive properties that make them appropriate for being combined with polymers, especially PET (polyethylene terephthalate), the most commonly used polymer in the packaging sector. Nevertheless, ZnO NPs have a potential ecotoxicity that could be reflected in PET-ZnO composites reaching the environment in the form of micro(nano)plastics. To assess the potential release of PET-ZnO, as well as the ecotoxicity of ZnO NPs, PET-ZnO and weathered composites were analyzed. The ecotoxicity of PET-ZnO was tested in organisms representing different food-chain levels and compared to ZnO NPs' ecotoxicity. The composite form contained a stable dispersion of around 3.7% of NPs uniformly scattered in the polymeric matrix. ZnO NPs were toxic to *Vibrio fischeri* and *Brachionus calyciflorus*. PET-ZnO did not exhibit any toxicity to the organisms studied, while a moderate level of toxicity was observed for the weathered forms.

Keywords: micro(nano)plastics; risk management; environmental



Citation: Fito López, C.; Díaz Soler, B.; Guillem-Amat, A.; Andreu Sánchez, O. Insights into the Potential Effects of Micro(nano)plastic-Containing Nanoparticles in the Environment. *Sustainability* **2023**, *15*, 16319. <https://doi.org/10.3390/su152316319>

Academic Editors: Natalia Liora, Dimitrios Melas, Athena Progiou and Evangelos Bakeas

Received: 17 August 2023

Revised: 9 November 2023

Accepted: 20 November 2023

Published: 26 November 2023



Copyright: © 2023 by the authors. Licensee MDPI, Basel, Switzerland. This article is an open access article distributed under the terms and conditions of the Creative Commons Attribution (CC BY) license (<https://creativecommons.org/licenses/by/4.0/>).

1. Introduction

Polymeric materials play an essential role in the development of packaging systems because of their chemical and mechanical properties, their low weight and cost, their malleability, and their remarkable diversity in physical properties [1]. Polymers are of special interest for foodstuff [2], and the principal polymers used to contact with food include polyolefins such as polypropylene (PP) and polyethylene (PE), polyethylene terephthalate (PET), polystyrene (PS), polyvinyl chloride (PVC) or polylactic acid (PLA) [3]. However, these materials possess some weaknesses such as a low thermal resistance, a low gas barrier to oxygen or carbon dioxide, or a low mechanical resistance. Due to these limitations, new approaches are being developed in the packaging industry based on the use of nanotechnology, which allows the development of new materials with new functional properties in order to better protect the quality and the security of products [1,3].

In packaging systems, nanoparticles (NPs) are absorbed into a polymeric matrix, giving place to nanocomposites that reduce their mobility and aggregation, preventing their migration to the environment and increasing their security [4]. Metallic oxide NPs (for example, TiO₂, SiO₂, and ZnO) are the most used NPs; they permit to optimize UV absorption and to increment rigidity, strength, and polymers' useful life. In addition, they provide antimicrobial properties and oxygen absorption to maintain freshness.

ZnO nanoparticles are among the most used nanoparticles worldwide [5,6] due to their excellent physicochemical properties, which could result in their unavoidable release

from industrial sites and accumulation in various aquatic environments [7]. Nowadays, ZnO NPs are used in products such as plastics, ceramics, glass, cement, rubber, lubricants, paints, pigments, food, batteries, flame retardants, electronics, solar cells, chemical and textile fibers. They are also used in cosmetics and sun creams because of their excellent UV absorption and their reflecting properties, and in a wide range of environmental control systems and technologies, from pollutant remediation to medical disinfection [8–10].

In the case of ZnO-based composites used in packaging materials, microplastics can be generated from a variety of sources, including the breakdown of larger plastic items, abrasion of packaging materials during end-of-life processes, and the fragmentation of plastic waste. These particles can become airborne and be transported by wind, potentially leading to their presence in the atmosphere. Moreover, nanoplastics, being even smaller, could potentially be formed through further degradation of microplastics or through direct release from certain sources such as nanoparticle-containing products or industrial processes [11], as is the case of packaging materials' production, use, and end-of-life processes. A scheme of the potential sources of release is depicted in Figure 1.

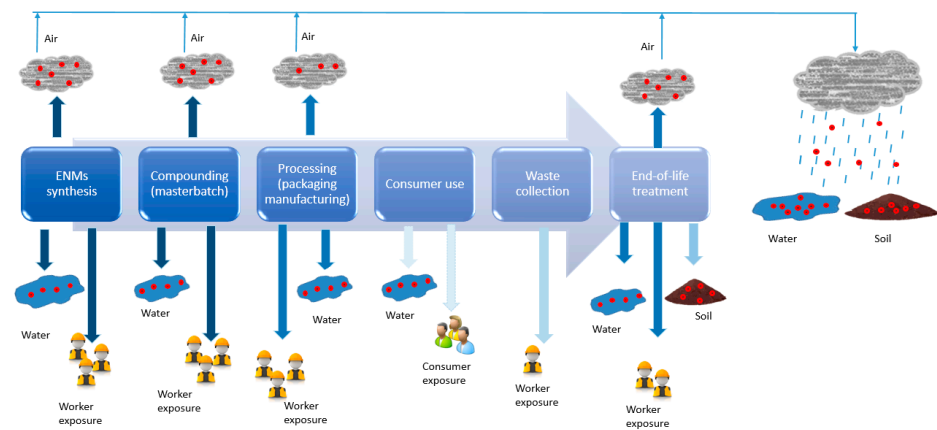

Figure 1. Micro(nano)plastics release across the life cycle of nanocomposite packaging.

The increase in the production rates worldwide and the widespread applications of ZnO NPs increase the potential for their release into the environment. In Europe, 10 ng/L of NPs is found in superficial waters (i.e., inland lakes and rivers) and 2.9 µg/L in the sediment [12], and these levels are supposed to increase [10]. Unfortunately, the information of ZnO NPs' ecotoxicological effects is still very limited [9,10]. The release of micro(nano)plastics into the environment is a key topic of the Circular Economy Action Plan and the Zero Pollution Action Plan, both main building blocks of Europe's new agenda for sustainable growth.

The unique physical and chemical properties of nanoscale materials that make them more efficient in their industrial applications also make them more harmful to the live beings [5]. This is why NPs' security has been questioned on several occasions by public and private institutions because of the risks that they could pose [4]. The safety of chemical and materials is of prime importance under the Chemicals Strategy for Sustainability, adopted by the European Commission last October 2020, whose main aim was to better protect citizens and the environment from harmful chemicals, and to develop safe and sustainable advanced materials and related technologies with a low environmental footprint.

In order to determine the potential risks of nanoscale materials, the toxicity inherent to the material, the way in which it interacts with the cells, and the exposure time effect have to be known [4]. In addition, information is required on the ability to move from one compartment to another, on the possible hazard that NPs can cause to the organisms, and how NPs are modified when they reach the environment [13].

In aquatic media, NPs would be pollutants with an ecotoxicological impact in freshwater and marine ecosystems because they can follow different aquatic paths to finally reach the sea. The behavior and toxicity of NPs in marine media differ from those in

freshwater ecosystems [14]. Recent publications show potential effects in different organisms, including long-term effects in *Daphnia magna* [14,15], as well as alterations at the molecular level [16] in *Daphnia magna* upon exposure to magnetic r-GO supporting anatase and γ -Fe₂O₃ NP nanocomposites. Moreover, current research also shows the ecotoxicological effects of copper oxide nanoparticles on amphibians related with the production of reactive oxygen species (ROS) [17]. The effects of TiO₂ are also well reported in the literature, including a set of representative EC50 values based on studies at multiple trophic levels [18].

In marine media, anions such as Cl⁻, SO₄(2⁻), CO₃(2⁻), or PO₄(2⁻) can act as union bonds and bind to Zn²⁺ ions making them precipitate and reducing their bioavailability [10].

ZnO NPs' toxicity depends on solubility and photoreactivity. Solubility is determined by NPs' intrinsic properties and by the exposition media. A high superficial area is one of the principal causes of a major dissolution. An acidic pH causes a greater release and dissolution of Zn²⁺ ions [10]. The solubility of NPs to Zn²⁺ makes them more toxic, and the total toxicity is due to the combination of dissolved Zn²⁺ and NPs [19].

In general, existent methods for risk evaluation are adequate to work with nanomaterials [5,9,20,21]. Nevertheless, in all cases it will be details that should be modified or optimized in order to properly work with them, such as dispersion conditions, NPs' color, or their adsorption properties [5,20]. Analogously to what happens with the all other chemical products, NPs are ecotoxicologically classified according to their response to the most sensitive organism [22].

The aim of the present research was to characterize the potential effects of PET-ZnO nanocomposites by studying ZnO NPs and the composite when the latter has just been manufactured and in its weathered form, after spending some time in the environment due to its potential release at different stages of the life cycle. This study also focused on the evaluation of PET-ZnO's (new and weathered) ecotoxicity and its comparison against the ZnO NPs' ecotoxicity. Organisms from different trophic levels and from different ecosystems were analyzed by standardized bioassays for the testing of chemical products. The outcomes of the studies conducted will also support the definition of sustainability principles to reduce the impact of nanotechnology-based products in the environment, as well as to transform the European advanced materials sector sustainably by generating new data on the potential impact in representative organisms.

2. Materials and Methods

2.1. Materials Characterization

2.1.1. Microscopic Characterization

ZnO NPs and PET-ZnO micronized nanocomposite were visualized and characterized with a scanning electron microscopy (S-4800, HITACHI; Universitat de València, Valencia, Spain). The nanocomposite was also subjected to an X-ray microanalysis (EDX) with the same microscopy (20.0 kV) to determine the sample composition.

2.1.2. ZnO NPs Content in the Nanocomposites

The real NP content in PET-ZnO and PET-ZnOw nanocomposites was determined by a thermogravimetric analysis (TGA) (Q5000IR thermogravimetric balance, TA instruments, New Castle, DE, USA), exposing 5–10 mg of the sample to a degradation cycle (20 °C/min in the temperature range of 15–875 °C). After the cycle, all the polymer was degraded, and the inorganic content was determined. The assay was performed twice.

2.1.3. Migration Study

ZnO NPs' migration potential from PET-ZnO to a food simulant was evaluated, as it is indicated in the 10/2011 UE regulation. The assay conditions were: 10 days at 50 °C (simulant: 10% ethanol and 3% acetic acid) and 1 day at 50 °C (simulant: isooctane). NPs' liberation was determined by weight difference. After the contact period, samples were collocated in an oven at 120 °C to evaporate the simulant and dry the residue. The samples

were collocated into a dryer and weighed. Cycles of heating, cooling and weighing were repeated until the weights differed by only 0.5 mg. Pure PET was used as a control to correct migration values. The migration potential of ZnO NPs from the composite to the environment was calculated with this expression:

$$M (\%) = \frac{m - m_o}{m^*} \cdot 100$$

where M is the potential migration (%); m is the PET-ZnO residue weight (g), m_o is the PET residue weight (g), and m^* is the total ZnO NPs content determined by TGA.

2.2. Ecotoxicity Bioassays

2.2.1. Bioassays Validation

With *Vibrio fischeri*, the toxic effect of CuSO_4 was studied as reference. In this case, testing concentrations were chosen based on previous studies [16,17]. There was no reference toxicant for the plants, so this bioassay was tested with Milli-Q water to find out if the seeds germinated properly.

2.2.2. Luminescence Inhibitory Effect of *Vibrio fischeri*

Vibrio fischeri was used as a detritivore organism. For the bioassay, the Toxi-Screening Kit™ (MicroBioTests Inc., Gent, Belgium) was used, and it followed the ISO 11348-1 [23] regulation. Samples were prepared in 2% NaCl saline media [13]. The tested concentrations were 1.6, 3.1, 12.5, and 100 mg/L [14,24]. Saline media was also used as a control. Before the assay, we checked whether samples had an inherent luminescence. Sample luminescence was measured at the beginning of the assay and after 30 min in order to see if a light emission decrease occurred. All luminescence measures were performed with the same luminometer (Lumitester PD-10, Kikkoman Corporation, Chiba, Japan). The inhibition percentage (I%) was calculated as follows [14,24,25]:

$$\% = 100 - \frac{URLs\ t30}{\left(\frac{URLc\ t30}{URLc\ t0}\right) \cdot URLs\ t0} \cdot 100$$

where $URLs\ t0$ is the sample initial luminescence value; $URLs\ t30$ is the sample luminescence value after 30 min; $URLc\ t0$ is the control initial luminescence value; and $URLc\ t30$ is the sample luminescence value after 30 min.

The bioassay was performed three times; the inhibition percentage was calculated, and the 30 min-EC50 was estimated as well.

2.2.3. Growth Inhibition in Marine Algae

Phaeodactylum tricornutum was used as a marine primary producer. The Algaltoxkit MTM (MicroBioTests Inc., Gent, Belgium) was used, and the bioassay adhered to the ISO 10253 [26] regulation and the OECD 201 guide. Samples were prepared in ISO medium, which was also used as a control. The algae were exposed to different concentrations of ZnO NPs, PET-ZnO, and PET-ZnOw.

There were three replicates in both bioassays. The optical density (OD) of each sample was measured with a spectrophotometer ($\lambda = 670$ nm) (CE 2021, Cecil Aurius Series) at 24, 48, and 72 h after the inoculation. For each sample, the zero was marked on the spectrophotometer with a solution of the culture medium to prevent the absorbance of the material from interfering in the reading. Daily medium OD of the three replicates of each concentration was estimated to later calculate the algae growth inhibition and the 72 h-EC50.

2.2.4. Acute Ecotoxicity Bioassays with Marine Rotifers

Brachionus calyciflorus was used as a freshwater primary consumer. The Rotoxkit FTM (MicroBioTests Inc., Gent, Belgium) was used, and the bioassay adhered to the ASTM

E1440-91:2012 [27] guide. Samples were prepared in ASTM medium, which was also used as a control. The rotifers were exposed to preselected concentrations of ZnO in the nanometer range and to 100 mg/L of the nanocomposites.

Alive and dead rotifers were counted with a stereomicroscope (XTL 6445, OPTIKA S.r.l, Ponteranica, Italy) after a 24 h incubation. Data analysis was conducted with EPA PROBIT v.1.541, which calculated the mortality percentage in the control group and in the different concentrations of each material to obtain the 24 h-LC50 value.

2.2.5. Determination of the Nanomaterials' Direct Effects in the Seed Germination and in the Early Growth of Higher Plants

Lepidium sativum, *Sinapis alba*, and *Sorghum saccharatum* were used as higher plants. The Phytotestkit™ (MicroBioTests Inc., Gent, Belgium) was used and the bioassay adhered to the OECD 208 guide and EPA 712-C-96-154 [28] regulation. Samples were prepared in Milli-Q water, which was also used as a control. Ten seeds of each plant were exposed to 100 mg/L of the materials.

After a 72 h incubation, the plants were scanned and analyzed with ImageJ for the analysis of germinated seeds and the root and tail growth. The germination inhibition and the root and tail growth with respect to those of the control were calculated as indicated in the kit. With these values, 72 h-EC50 was estimated for the three effects.

2.2.6. Ecotoxicity in the Trophic Chain

Bioassay results were analyzed together to determine the effects of ZnO NPs, PET-ZnO, and PET-ZnOw in the trophic chain. Substances were classified according to their E/LC50 value for each organism according to the ecotoxicity scale established by Bondarenko et al. [5], adopted from the 93/67/EEC European regulation and from previous studies. This scale classified as “extremely toxic” the E/LC50 values comprised between 0 and 0.1 mg/L, “very toxic” those between 0.1 and 1 mg/L, “toxic” the 1–10 mg/L values, “moderately toxic” the 10–100 mg/L values, and “not toxic” the 100–1000 mg/L values (in general, all the values over 100 mg/L).

2.3. Release Estimation

A probabilistic approach was adopted in the present work in order to estimate the release potential during the service life of nanocomposite packaging. The model used for estimating the environmental release of micronanoplastics (MNPs) across the life cycle of nanocomposite packaging is depicted in Figure 2. The approach followed was a multimedia high-level probabilistic material flow analysis (MFA) model based on a Monte Carlo simulation method. It consisted of 23 flows and 6 processes.

Each of these flows was assigned with a probability distribution that represented the uncertainty of the flow. During nanocomposite manufacturing, quantities of ZnO-MNPs are released into the air, soil, and water. These three material flows are represented by the flows 20, 21, and 22, respectively, whereas flow 16 represents the quantity of ZnO-MNPs that reaches the facilities where the nanoparticle (in this case the packaging) is manufactured.

Again, during the nanoparticle manufacturing, MNPs may be released to the three environmental compartments (represented by flows 17, 18, and 19). Packaging products then enter the use stage. During the use stage, quantities of MNPs containing ZnO nanoparticles are also expected to be released although in quantities substantially smaller than the ones during the manufacturing stage. Finally, waste packaging may be recycled, incinerated (WIP), or disposed of in landfill. Waterborne ZnO-MNPs, on the other hand, will end up in sludge treatment plants (STP).

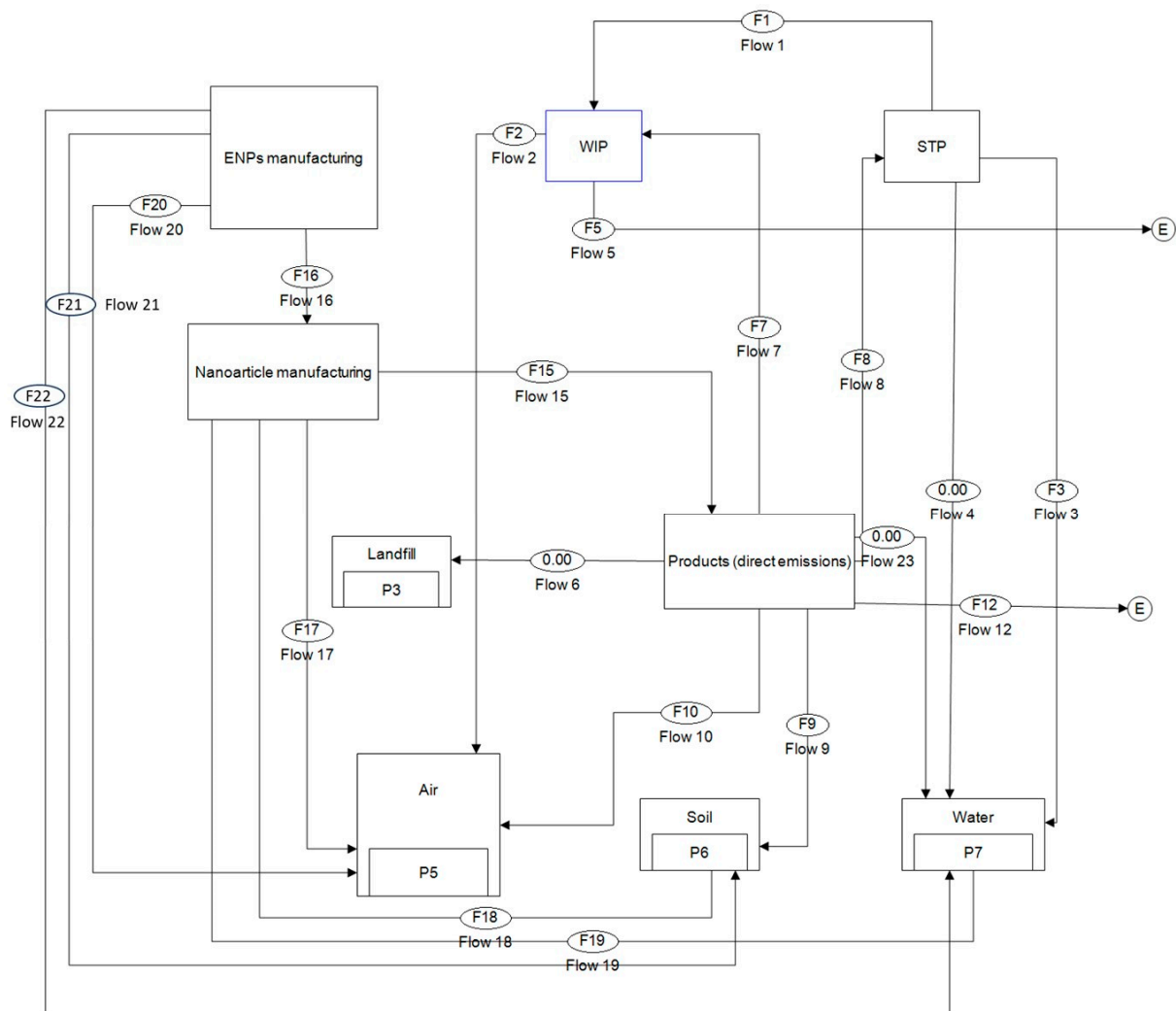

Figure 2. pMFA environmental model for micro(nano)plastics release estimation.

At the incineration plant, some of the MNPs are combusted (flow 5), and the ones that have not been combusted and have managed to bypass the filter are finally released into the air (flow 2). Furthermore, waterborne ZnO-MNPs that reach the wastewater treatment plant (STP) can end up in the sludge (the majority) or be discharged to the water bodies with the treated water (flow 3). ZnO-MNPs contained in sludge are then taken to the incineration plant (flow 1).

The model also takes into consideration the waste that is disposed of in landfill. Landfill flow is represented by flow 6. Last, recycling (mainly shredding) is expected to generate airborne MNPs. It should be noted that not all the ZnO particles embedded in the matrices become airborne as some of them remain in the polymeric matrix and therefore eventually end up in new products. Due to the lack of data, in this study, the quantity of NPs that enters the recycling facilities was excluded from the system (flow 12).

The probability distributions were created based on core values: during the synthesis of ENMs, 5% of them would be released in the air, 6% in water, and 0.01% in soil. In the model, these values were used as core values for generating random values. For the random data generation, the uncertainty was set at 10% and the threshold uncertainty at 0.001%. The random values followed uniform, normal, or triangular probability distributions depending on the data and knowledge availability. Five thousand random values were generated for each of the core values.

Similarly, in the case of nanoparticle manufacturing, which, for packaging, includes the compounding process and the packaging manufacturing, the central values used were 15% for air, 1% for water, and 0% for soil.

Finally, regarding the use and end-of-life stages, during the use of packaging by the consumers, and due to the weathering of the packaging products, it was estimated that 5% would be released in the air, 5% into the soil, and another 5% into the water.

Waterborne ZnO-MNPs will reach the STP plants. After the water processing, it was estimated that 97% of the MNPs would be removed from water, whereas 3% would be discharged with treated water. It was assumed that the sludge containing 97% of the MNPs removed from water would then be incinerated.

It was estimated by the authors as an assumption that 35% of the packaging that consumers throw away is taken to the recycling plant. This last assumption was based on the data published by the European Parliamentary Research Service in 2023 (PE 745.707—March 2023), as well as the EU 28 + 2's average recycling rate of plastic packaging, which reached a value of 40.8% in 2017. As stated above, once MNPs enter the recycling plant, they were considered excluded from the system. Regarding incineration, it was considered that of the packaging waste thrown away, 50% was incinerated. Of this amount, 70% was combusted. A filter was then considered to retain 99% of the unburnt ZnO-MNPs, therefore only leaving in the atmosphere 1%. The abovementioned release values used in the study are depicted in Figure 3.

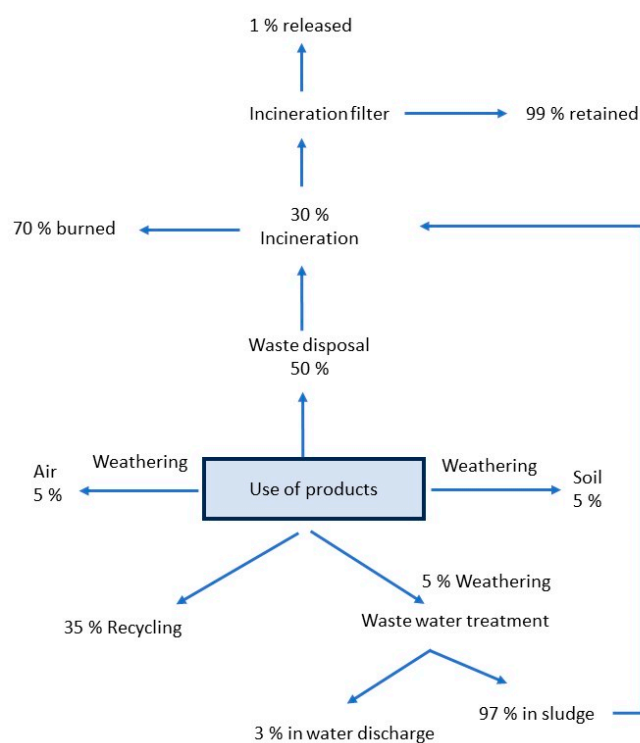

Figure 3. Core release values from use and end-of-life stages.

3. Results

3.1. Material Characterization for Ecotoxicity Tests

This characterization consisted in a full characterization and description of the ZnO nanoparticles, covering particle size, shape, mass, surface area, chemical composition, and physical and optical properties by means of specific techniques, including transmission electron microscopy (TEM), scanning electron microscopy (SEM), thermogravimetric analysis (TGA), Fourier transform infrared spectrometry (FT-IR), photocatalytic activity, surface area, redox potential, and particle size distribution (PSD). Available information on the physicochemical properties of the ZnO NPs is depicted in Table 1. A set of representa-

tive TEM pictures of ZnO micro(nano)particles is provided in Figures 4 and 5. The size distribution of the materials is depicted Figure 6.

Table 1. Obtained physicochemical properties.

Material	Type	Appearance	Average Primary Particle Size (nm)	Pore Diameter (Å)	S_{BET} (m ² /g)	Redox Potential (E(V) vs. Ag/AgCl in H ₂ O)	Composition	Shape
Zinc oxide–ZnO	Metal Oxide	White powder	213.5	31	9	0.246	≥99%	Hexagonal–zincite

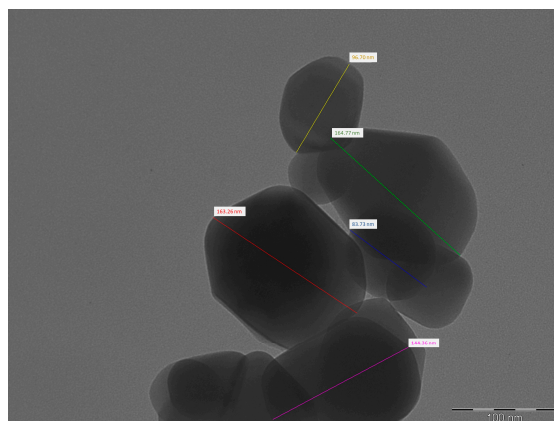

Figure 4. Representative TEM picture of ZnO nanoparticles used for the size distribution analysis.

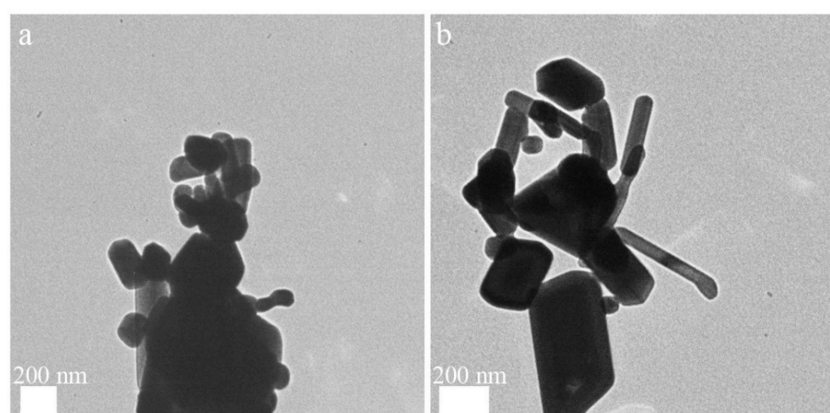

Figure 5. Representative TEM pictures of ZnO nanoparticles.

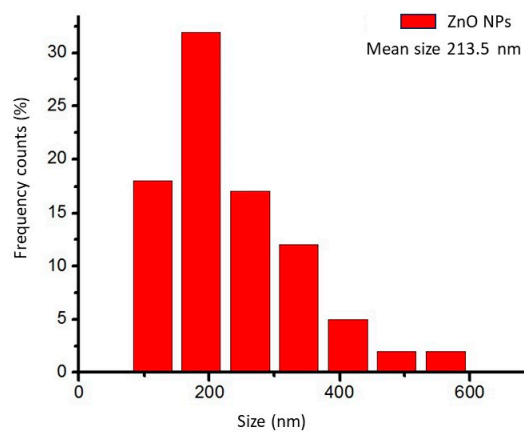

Figure 6. Size distribution histogram regarding ZnO micro(nano)particles.

As can be seen from the TEM pictures shown in Figure 5a,b, ZnO crystals do not possess a uniform size and shape, with different shapes, including prisms and spheres. This situation can be also observed in the statistical analysis shown in Figure 6.

Regarding the ZnO NP content in the nanocomposites, the TGA determined that PET-ZnO had a ZnO NP content of $3.71 \pm 0.04\%$, while PET-ZnOw had one of $3.56 \pm 0.10\%$. Both values corresponded approximately to the theoretical value (4%).

The size distribution of the materials is depicted in the figure below.

3.2. Ecotoxicity Testing

The results from the *V. fischeri* (30 min-EC50), *P. tricornutum* (72 h-EC50), and *B. calyciflorus* (24 h-LC50) bioassays fell into the range allowed and outlined in current regulations (Table 2). In the case of the plants, the assays with Milli-Q water were also satisfactory (100% germination in all cases).

Table 2. Summary of the results (mg/L) retrieved in the bioassays' validation with the reference toxicants and the reference values given by the manufacturer or by the guides.

Organism	Toxicant	Endpoint	Result (mg/L)	Reference (mg/L)
<i>V. fischeri</i>	K ₂ Cr ₂ O ₇	30 min-EC50	78.92	-
	CuSO ₄	30 min-EC50	4.21	- ^a
<i>P. tricornutum</i>	K ₂ Cr ₂ O ₇	72 h-EC50	9.09 (8.89–9.29)	9.15 (manufacturer)
<i>B. calyciflorus</i>	K ₂ Cr ₂ O ₇	24 h-LC50	12.4 (8.3–16.5)	13.7 (9.6–17.8) (manufacturer)

^a This toxicant was used in this study as a reference because it had been used in previous studies found in the literature [24,25].

3.2.1. Luminescence Inhibitory Effect of *Vibrio fischeri*

None of the materials presented any background luminescence. The results of *V. fischeri*'s luminescence inhibition is shown in Figure 7.

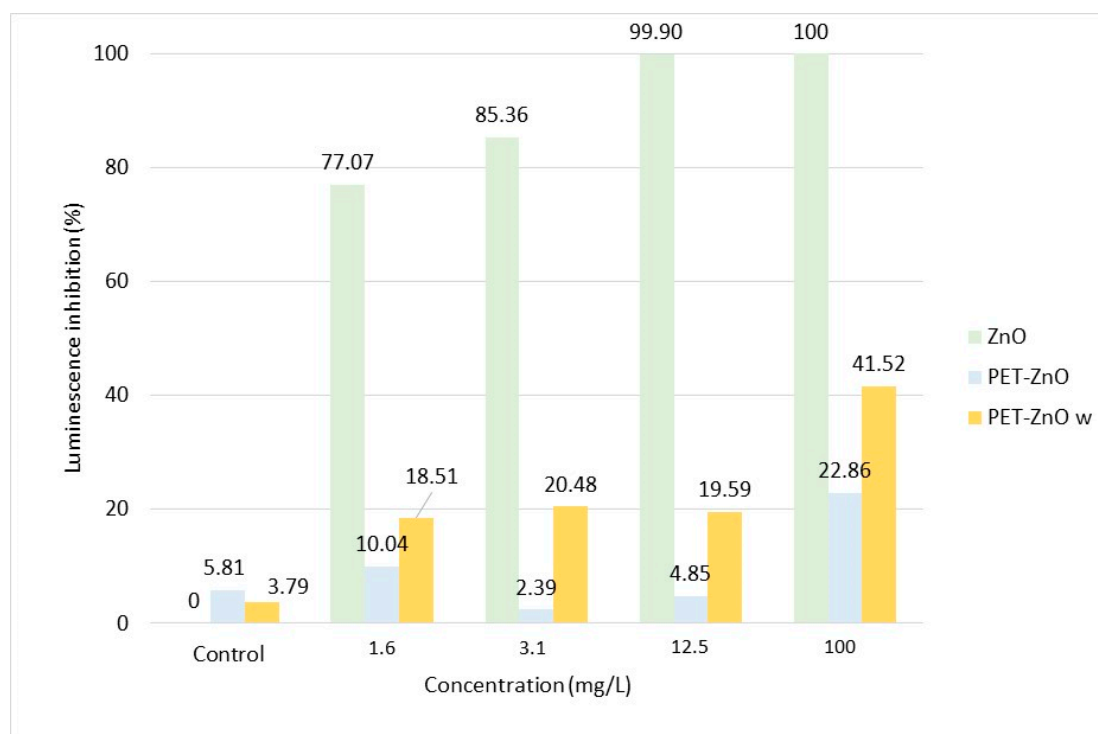

Figure 7. *Vibrio fischeri*'s luminescence inhibition percentage at the different evaluated concentrations of the studied materials after a 30 min of incubation.

ZnO NPs were the most toxic material, followed by PET-ZnOw and PET-ZnO. Previous studies established a 20% threshold to determine that a relation between the toxicant and the luminescence inhibition existed [14,24,29]. ZnO NPs presented values over that threshold since they had the lowest tested concentration, while PET-ZnO only got over it at a concentration of 100 mg/L and PET-ZnOw rounded the 20% at 3.1 mg/L. The 30 min-EC₅₀ was calculated with these values (Table 2).

These results were similar to the ones retrieved from previous studies, as well as those we expected to obtain because of the materials' characteristics. In the case of ZnO NPs, the 30 min-EC₅₀ to *V. fischeri* bibliographic values were between 1.9 ± 0.2 mg/L and 4.8 ± 1.1 mg/L [14], the 30 min-EC₅₀ value of this study being very low (2.39 mg/L). The toxicological behavior can be attributed to the generation of ROS and the physical damage caused by the NPs. Previous studies on nanocomposites ecotoxicity were not found. However, the observations retrieved agreed with the ones we expected to obtain in view of the materials' characteristics, showing that the immersion of NPs inside the polymeric matrix limited their toxicity by decreasing their liberation to the environment. PET-ZnOw showed a higher luminescence inhibition percentage due to the weathering process that degraded the nanocomposite surface, allowing NPs to escape in a larger proportion.

3.2.2. Growth Inhibition in Marine Algae

In the marine media, none of the tested materials was ecotoxic to *P. tricornutum* according to what was seen in growth inhibition percentages (Figure 8) and in the 72 h-EC₅₀ values (Table 3). However, ZnO NPs already demonstrated an ecotoxic potential in previous studies with *P. subcapitata* (freshwater algae): a 72 h-EC₅₀ of 0.042 mg/L [30] or 0.049 mg/L [31]. Both studies attributed the toxicity to the solubilized Zn²⁺ ions. ZnO NPs also demonstrated a high toxicity in other species of freshwater algae: a 72 h-EC₅₀ of 0.013 mg/L in *Chlorella vulgaris* and 0.09 mg/L in *Scenedesmus dimorphus* [32].

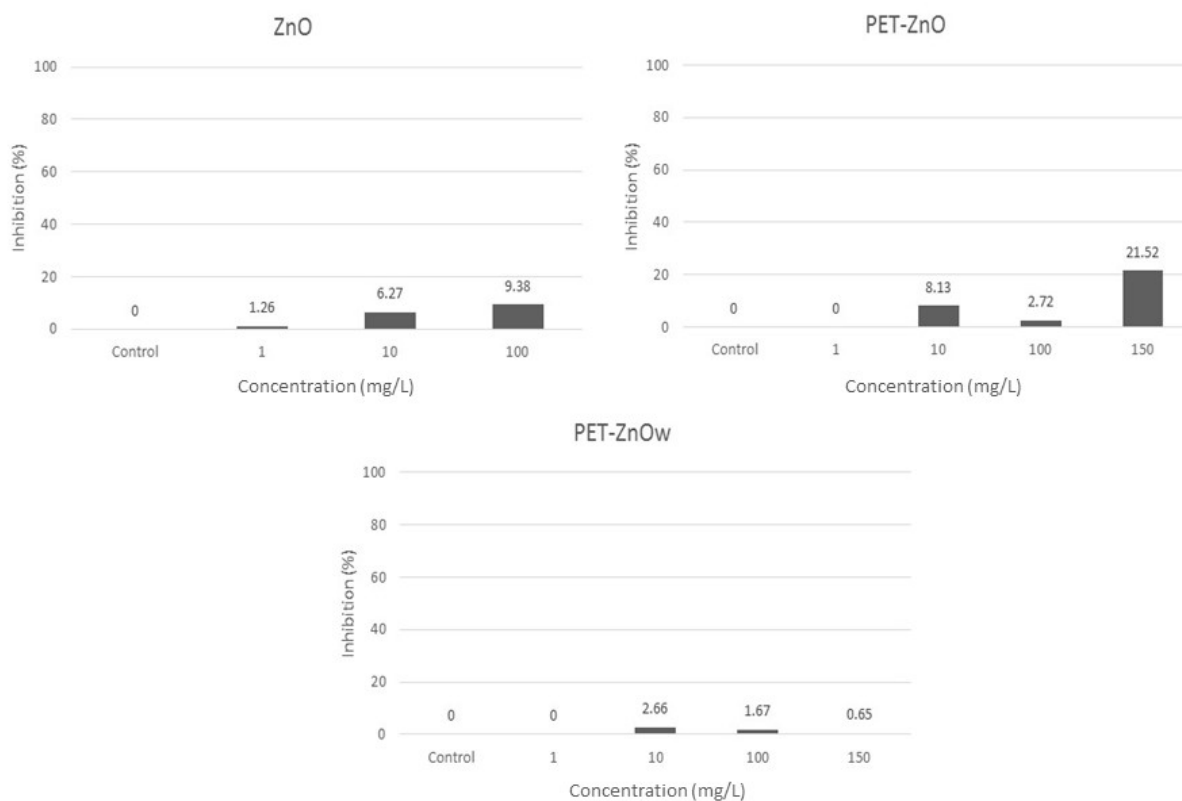

Figure 8. Growth inhibition percentages of *Phaeodactylum tricornutum* at each of the tested concentrations with ZnO NPs, PET-ZnO, and PET-ZnOw.

Table 3. The 30 min-EC50 (*Vibrio fischeri*), 72 h-EC50 (*P. tricornutum*) and 24 h-LC50 (*B. calyciflorus*) values of the tested organisms.

Organism	Toxicant	Endpoint	Value (mg/L)	CI * (95%) (mg/L)
<i>V. fischeri</i>	ZnO	30 min-EC50 (luminescence inhib.)	2.39	-
	PET-ZnO		>100	-
	PET-ZnOw		>100	-
<i>P. tricornutum</i>	ZnO	72 h-EC50 (growth inhib.)	107.92	102.20–129.85
	PET-ZnO		188.71	176.79–244.10
	PET-ZnOw		192.66	179.57–192.75
<i>B. calyciflorus</i>	ZnO	24 h-LC50	6.12	5.56–6.66
	PET-ZnO		>100	-
	PET-ZnOw		>100	-

* CI: confidence interval.

This indicated that there was a strong dependence of ZnO NPs' ecotoxicity and the organism habitat: in the marine media, Zn²⁺ precipitated because of the interaction with Cl⁻ and the formation of ZnCl₂⁷. Then, NPs were not available for damaging the algae.

3.2.3. Acute Ecotoxicity Bioassays with Freshwater Rotifers

In the experiment with *B. calyciflorus*, nanocomposites presented a mortality percentage of 0% at 24 h and 100 mg/L (Table 3). In the case of ZnO NPs, a screening test was conducted with concentrations between 0 and 10 mg/L, and a progressive increase in their toxicity was noticed, with a 24 h-LC50 of 6.12 mg/L (Table 3).

The ZnO NPs' 24 h-LC50 value of a previous study with *B. calyciflorus* was of 0.6 ± 0.1 mg/L [21], lower than the one obtained in this study. This difference could be due to interlaboratory differences during the sample preparation. Previous studies with ZnO NPs and *Daphnia magna* [32–34], another primary consumer of freshwater, presented E/LC50 values similar to the ones obtained with *B. calyciflorus* in this study: 48 h-LC50 values of 3.2 ± 1.3 mg/L and 7.5 mg/L, and 48 h-EC50 values of 0.62 mg/L (comprised between 0.41 and 0.8 mg/L) and 2.6 ± 1 mg/L.

Toxicity did not increase with the weathering process of the nanocomposite, because PET-ZnOw showed a 24 h-LC50 value higher than 100 mg/L, which classified it as innocuous.

3.2.4. Determination of the Nanomaterials' Direct Effects on the Seed Germination and Early Growth of Higher Plants

The results of the studied materials' effects over the studied plants appear in Figure 9. PET-ZnOw specially affected root growth inhibition, although in *S. saccharatum*, its biggest effect was the steam growth inhibition. Nevertheless, this nanocomposite stimulated the germination of the three plants. PET-ZnO's more remarkable effect was the stimulation of root growth in *S. alba* (23.8%) and of steam growth in *S. saccharatum* (45.87%). ZnO NPs only had a remarkable inhibition effect over *S. alba* steam (28.91%), while the root growth stimulation of *L. sativum* (34.04%) and *S. alba* (47.11%) were especially noteworthy. In none of the cases was the 50% inhibition percentage reached, so the three plants had a 72 h-EC50 over 100 mg/L for the three effects (Table 4), and it could be stated that none of the three materials implied a huge environmental risk. However, PET-ZnOw's results could indicate a long-term risk, because the materials are suspected to be in this form after getting into the environment. Previous studies with ZnO NPs and *L. sativum* stated that they did not affect the seed germination and that they provoked a small root growth reduction (over 25%) at a concentration of 286 mg/kg and 1000 mg/kg. It was also observed in *Allium sativum* with 50 mg/L. With *Cucurbita pepo* and 1000 mg/L, there were no effects on germination or root elongation [35].

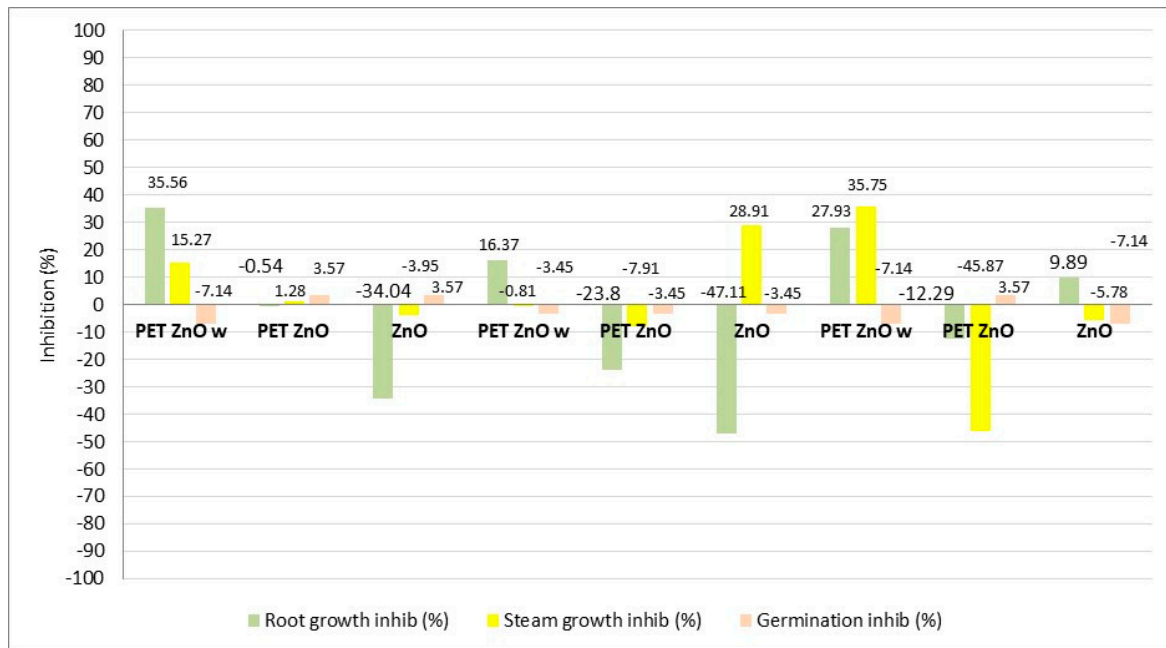

Figure 9. Root and steam growth inhibition and seed germination percentages of *Lepidium sativum*, *Sinapis alba*, and *Sorghum saccharatum* exposed to ZnO NPs, PET-ZnO, and PET-ZnOw.

Table 4. The 72 h-EC50 (*L. sativum*, *S. alba* and *S. saccharatum*) values of the tested organisms.

Organism	Toxicant	Endpoint	Value (mg/L)	CI * (95%) (mg/L)
<i>L. sativum</i>	ZnO	72 h-EC50 (root growth inhib.)	>100	-
		72 h-EC50 (steam growth inhib.)	>100	-
		72 h-EC50 (germination inhib.)	>100	-
	PET-ZnO	72 h-EC50 (root growth inhib.)	>100	-
		72 h-EC50 (steam growth inhib.)	>100	-
		72 h-EC50 (germination inhib.)	>100	-
	PET-ZnOw	72 h-EC50 (root growth inhib.)	>100	-
		72 h-EC50 (steam growth inhib.)	>100	-
		72 h-EC50 (germination inhib.)	>100	-
<i>S. alba</i>	ZnO	72 h-EC50 (root growth inhib.)	>100	-
		72 h-EC50 (steam growth inhib.)	>100	-
		72 h-EC50 (germination inhib.)	>100	-
	PET-ZnO	72 h-EC50 (root growth inhib.)	>100	-
		72 h-EC50 (steam growth inhib.)	>100	-
		72 h-EC50 (germination inhib.)	>100	-
	PET-ZnOw	72 h-EC50 (root growth inhib.)	>100	-
		72 h-EC50 (steam growth inhib.)	>100	-
		72 h-EC50 (germination inhib.)	>100	-
<i>S. saccharatum</i>	ZnO	72 h-EC50 (root growth inhib.)	>100	-
		72 h-EC50 (steam growth inhib.)	>100	-
		72 h-EC50 (germination inhib.)	>100	-
	PET-ZnO	72 h-EC50 (root growth inhib.)	>100	-
		72 h-EC50 (steam growth inhib.)	>100	-
		72 h-EC50 (germination inhib.)	>100	-
	PET-ZnOw	72 h-EC50 (root growth inhib.)	>100	-
		72 h-EC50 (steam growth inhib.)	>100	-
		72 h-EC50 (germination inhib.)	>100	-

* CI: confidence interval (95%).

Zn is an essential micronutrient that normally appears in the grounds and in the fertilizers. In a high number of crops, the accurate Zn amount varies between 15 and 70 mg/L [36], so it is not strange that its presence did not imply serious toxicological effects. Nevertheless, ZnO NPs could develop toxicity signs in plants by a chemical effect of Zn^{2+} dissolved ions or by a stress generated by the NPs' physical characteristics, which could damage the roots [10,33]. In previous studies, it was also observed that light conditions significantly determined *L. sativum*'s response to NPs by increasing their toxicity. It was due to their photovoltaic properties and ROS production [37]. As in this study, the experiment with plants was carried out in darkness, and phototoxic effects could have been covered up. In other species, ZnO nanoparticles (NPs) and microparticles caused a significant biomass reduction, as it was reported in the medical plant *Fagopyrum esculentum* due to reactive oxygen species generation [38].

In previous studies it was observed that ground components, its characteristics, and the contact period affected the behavior of NPs and could provoke their aggregation, decreasing their mobility and bioavailability [39–41]; nevertheless, the phytotoxic effect in the plant could be potentiated to the point where the NPs become restrained [41].

3.3. Ecotoxicity in the Trophic Chain

As could be predicted with the bioassays results, ZnO NPs presented the highest ecotoxicity, and they were classified as “toxic” to *V. fischeri* and *B. calyciflorus*, while PET-ZnO and PET-ZnOw micro(nano)plastics were “not toxic” to almost every organism.

In the terrestrial ecosystem, although ZnO NPs pose a little risk to the plants, their accumulation can induce a negative effect in other organisms living in the ground such as bacteria, fungi, or earthworm. In addition, NPs could migrate from the ground to the groundwater and enter aquatic ecosystems.

As with the rest of chemical products, NPs are ecotoxicologically classified according to their response to the most sensitive organism [22]. That is why ZnO NPs could be classified as “extremely toxic”, PET-ZnO MNPs should be considered as a “nontoxic” material, and its weathered form (PET-ZnOw) could be classified as “moderately toxic”.

3.4. Release Estimation

This model was based on the estimated worldwide production of nanocomposites for packaging applications placed on the market, for particle release from products, and for flow coefficients within compartments selected for the model.

Figure 10 illustrates the histogram obtained from the model for the release of ENMs into the air. The model considered an estimated production of ZnO NPs of 3000 tons/year worldwide and 1000 tons/year in Europe. The model considered that 20% of the production in the polymer global market was dedicated to the manufacture of packaging materials. It was assumed that the ZnO NPs were introduced in polymers at rates of 4% and 7% (in mass), representing a realistic scenario (RE) and a high exposure scenario (HE), respectively.

As can be observed, the most frequent value was 28.895 kg. Similarly, the most frequent value for the water compartment was 9.226 kg (Figure 11) whereas in the case of soil, the most frequent value was 4.612 kg (Figure 12). In the case of the air compartment, the manufacturing of ENMs accounted for approximately 17.3% of these emissions, while compounding and packaging manufacturing accounted for approximately 49.32%. Last, the consumer use and end-of-life treatment accounted for 33.38%. In the case of water, ENM manufacturing was responsible for approximately 65.03%, while packaging manufacturing and consumer use, including end-of-life treatments, accounted for 10.19% and 24.78% of the total emissions, respectively.

Finally, and with regards to the soil compartment, 0.22% of 4.622 kg of ENMs came from the ENM manufacturing stage, and the rest, 99.78%, from the consumer use and end-of-life treatments. The emissions to freshwater during the consumer use and end-of-life treatments were estimated to be very low. All the results from the model are summarized in Table 5.

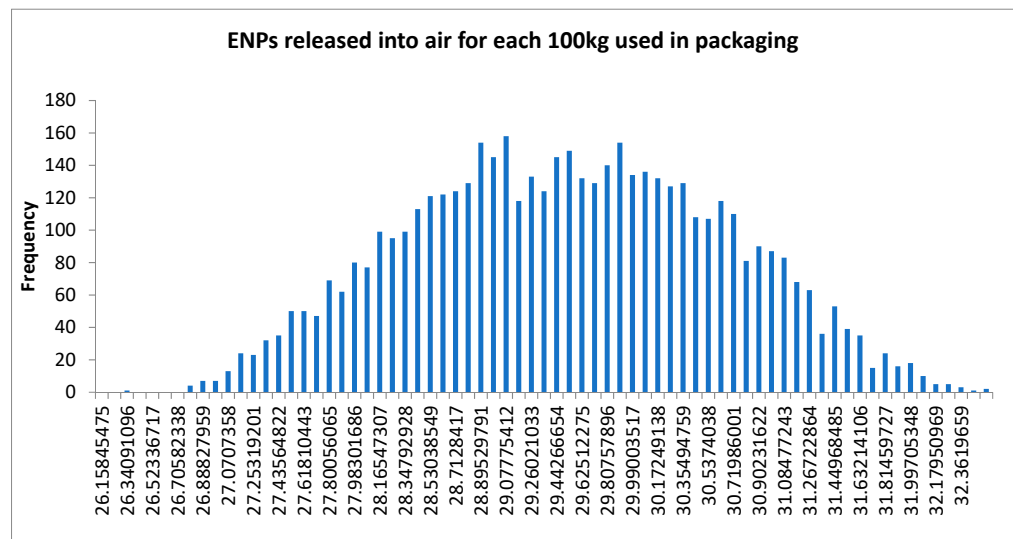

Figure 10. ENMs released into the air for each 100 kg used in packaging.

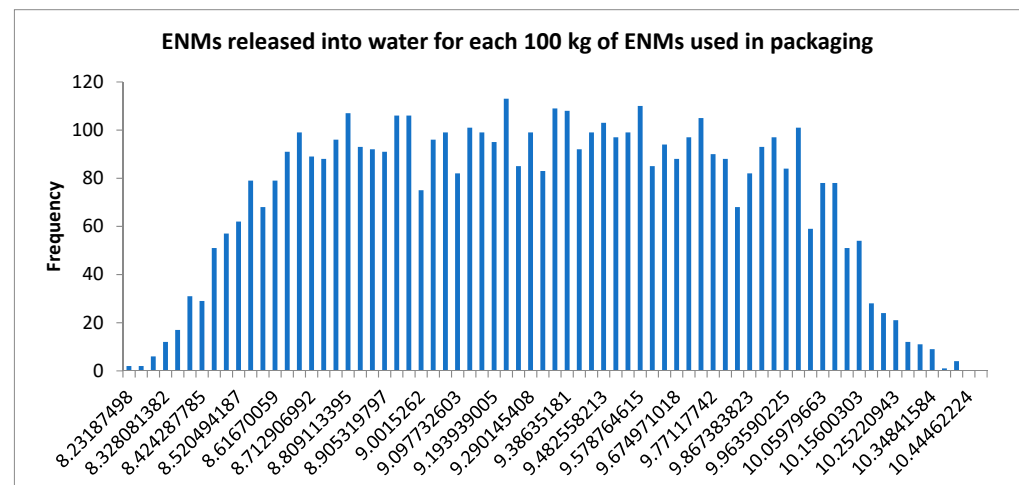

Figure 11. ENMs released into water for each 100 kg used in packaging.

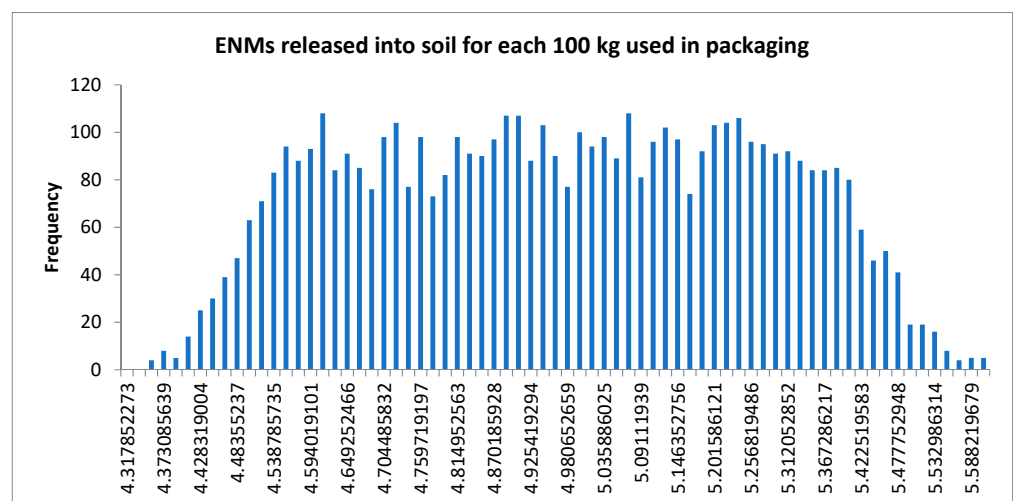

Figure 12. ENMs released into soil for each 100 kg used in packaging.

Table 5. Emissions of ENMs per life-cycle stage (for each 100 kg of ENMs used in packaging).

	Manufacturing of ENMs (kg)	Manufacturing of Nanoparticles (kg)	Use and End-of-Life Treatments (kg)
Air	5	6	0.01
Water	14.25	0.94	0
Soil	9.645	2.286	4.612
Total	28.895	9.226	4.622

4. Conclusions

PET-ZnO's characterization and its ecotoxicity study in organisms at different trophic levels was carried out to determine if it would be appropriate to use it in the packaging industry in a secure way, promoting the generation of new knowledge for developing sustainable products. The obtained results suggested these conclusions:

1. ZnO NPs are stably immerse in the PET matrix, avoiding their migration to the environment.
2. ZnO NPs are "toxic" to *V. fischeri* and *B. calyciflorus*. PET-ZnO is not toxic to any of the studied organisms.
3. ZnO NPs pose an acute risk in freshwater media, especially to the primary producers' group. In marine media, Zn^{2+} and Cl^{-} ions react to form $ZnCl_2$ that precipitates. This is why ZnO NPs are innocuous for *P. tricornutum*.
4. ZnO NPs are classified as "extremely toxic" to the environment, while their immersion in the PET matrix diminishes their toxicity and gives place to a PET-ZnO nanocomposite environmentally "not toxic".
5. The long-term ecotoxicologic effects of PET-ZnO should be studied deeper because it presents a potential ecotoxicity in the PET-ZnOw form and it is classified as "moderately toxic".

On the other hand, nanomaterials incorporated into a solid matrix are least likely to become airborne (inhalable) because of their reduced mobility. However, under certain circumstances these nanomaterials may still pose a risk. Based on the literature, the release of nanofillers can be a result of the degradation of the matrix due to the application of mechanical forces, weathering, or due to contact and washing. Currently, there is a considerable number of studies dealing with the release of nanofillers from nanocomposite products although the vast majority of them focus on applications other than packaging where the degradation of the matrix is more likely.

It can be concluded therefore that with the current knowledge, although there are risks associated with the use of nanoparticles in the packaging industry, these are more related to the activities/processes before and after the consumer use of the packaging. In fact, nanocomposite packaging should be viewed by the end-users as conventional packaging as it does not require any special treatment or handling by them. Nevertheless, and in order to ensure the sustainability and safe handling of waste nanocomposite packaging that is treated appropriately, it is strongly recommended that users dispose of their waste according to the waste management scheme of their location.

Finally, it should be noted that due the extremely heterogeneous properties of NPs and micro(nano)plastics, their identification/quantification in environmental media and complex biological matrices is one of the main challenges for future studies, considering that properties such as size, shape, surface composition, or surface reactivity can modulate any effects. This study provides insights into a particular type of NPs and micro(nano)plastics and provides a baseline of knowledge to support risk assessors and public bodies in better estimating the potential effects on human health and the environment of these type of materials, both key aspects under the chemicals strategy for sustainability. The outcomes of the study will also support the design, development, and uptake of sustainable materials towards a circular economy.

Author Contributions: Conceptualization, C.F.L. and O.A.S.; methodology, C.F.L. and O.A.S.; validation, C.F.L. and O.A.S.; investigation, C.F.L. and O.A.S.; resources, C.F.L. and O.A.S.; writing—original draft preparation, B.D.S. and A.G.-A. All authors have read and agreed to the published version of the manuscript.

Funding: This research was carried out as part of LIFE project NanoExplore funded by the European Commission' LIFE programme under grant agreement LIFE17 ENV/GR/000285, as well as the European project FP7 NanoSafePack project (G.A. 286362).

Institutional Review Board Statement: Not applicable.

Informed Consent Statement: Not applicable.

Data Availability Statement: Data are contained within the article.

Conflicts of Interest: Calos Fito-López, Oscar Andreu Sánchez, Beatriz Maria Diaz Soler, and Ana Guillem Amat declare that they have no conflict of interest.

References

1. Silvestre, C.; Duraccio, D.; Cimmino, S. Food packaging based on polymer nanomaterials. *Prog. Polym. Sci.* **2011**, *36*, 1766–1782. [CrossRef]
2. Koontz, J.L. Controlled Release of Active Ingredients from Food and Beverage Packaging. Italian Packaging Technology Award (IPTA) Paper Competition. 2006; p. 15. Available online: <https://www.iopp.org/files/public/vatechkoontzfinaledit.pdf> (accessed on 16 August 2023).
3. Fito, C. Report on the nanoclays and metal oxide nanoparticles employed on the packaging industry. In *Development of a Best Practices Guide for the Safe Handling and Use of Nanoparticles in Packaging Industries*; (NanoSafePACK), Grant number: 286362; ITENE: Valencia, Spain, 2012; p. 36.
4. Rana, S.; Kalaichelvan, P.T. Ecotoxicity on nanoparticles. *ISRN Toxicol.* **2013**, *2013*, 574648. [CrossRef] [PubMed]
5. Rauf, M.A.; Owais, M.; Rajpoot, R.; Ahmad, F.; Khan, N.; Zubair, S. Biomimetically synthesized ZnO nanoparticles attain potent antibacterial activity against less susceptible *S. aureus* skin infection in experimental animals. *RSC Adv.* **2017**, *7*, 36361–36363. [CrossRef]
6. Makhdoumi, P.; Karimi, H.; Khazaei, M. Review on metal-based nanoparticles: Role of reactive oxygen species in renal toxicity. *Chem. Res. Toxicol.* **2020**, *33*, 2503–2514. [CrossRef] [PubMed]
7. Wigger, H.; Kägi, R.; Wiesner, M.; Nowack, B. Exposure and possible risks of engineered nanomaterials in the environment—Current knowledge and directions for the future. *Rev. Geophys.* **2020**, *58*, e2020RG000710. [CrossRef]
8. Bondarenko, O.; Juganson, K.; Ivask, A.; Kasemets, K.; Mortimer, M.; Kahru, A. Toxicity of Ag, CuO and ZnO nanoparticles to selected environmentally relevant test organisms and mammalian cells in vitro: A critical review. *Arch. Toxicol.* **2013**, *87*, 1181–1200. [CrossRef] [PubMed]
9. Kahru, A.; Dubourguier, H.-C. From ecotoxicology to nanoecotoxicology. *Toxicology* **2010**, *269*, 105–119. [CrossRef]
10. Ma, H.; Williams, P.L.; Diamond, S.A. Ecotoxicity of manufactured ZnO nanoparticles—A review. *Environ. Pollut.* **2012**, *172*, 76–85. [CrossRef]
11. Shen, M.; Zhang, Y.; Zhu, Y.; Song, B.; Zeng, G.; Hu, D.; Wen, X.; Ren, X. Recent advances in toxicological research of nanoplastics in the environment: A review. *Environ. Pollut.* **2019**, *252*, 511–521. [CrossRef]
12. Gottschalk, F.; Sonderer, T.; Scholz, R.W.; Nowack, B. Modeled environmental concentrations of engineered nanomaterials (TiO₂, ZnO, Ag, CNT, Fullerenes) for different regions. *Environ. Sci. Technol.* **2009**, *43*, 9216–9222. [CrossRef]
13. Jøner, E.J.; Hartnik, T.; Amundsen, C.E. *Environmental Fate and Ecotoxicity of Engineered Nanoparticles*; Report Number: TA 2304/2007; Norwegian Pollution Control Authority: Oslo, Norway, 2008; 64p.
14. Heinlaan, M.; Ivask, A.; Blinova, I.; Dubourguier, H.-C.; Kahru, A. Toxicity of nanosized and bulk ZnO, CuO and TiO₂ to bacteria *Vibrio fischeri* and crustaceans *Daphnia magna* and *Thamnocephalus platyurus*. *Chemosphere* **2008**, *71*, 1308–1316. [CrossRef] [PubMed]
15. Huertas-Chambilla, M.Y.; Moyano-Arocutipa, M.F.; Zarria-Romero, J.Y.; Checca-Huaman, N.-R.; Passamani, E.C.; Arencibia, A.; Ramos-Guivar, J.A. In-Field 57Fe Mössbauer study of maghemite nanoparticles functionalized multiwall carbon nanotubes and their ecotoxicological properties in young *Daphnia magna*. *Hyperfine Interact.* **2022**, *243*, 1–14. [CrossRef]
16. Ramos-Guivar, J.A.; Zarria-Romero, J.Y.; Canchanya-Huaman, Y.; Guerra, J.A.; Checca-Huaman, N.-R.; Castro-Merino, I.-L.; Passamani, E.C. Raman, TEM, EELS, and Magnetic Studies of a Magnetically Reduced Graphene Oxide Nanohybrid following Exposure to *Daphnia magna* Biomarkers. *Nanomaterials* **2022**, *12*, 1805. [CrossRef] [PubMed]
17. Murthy, M.K.; Khandayataray, P.; Mohanty, C.S.; Pattanayak, R. Ecotoxicity risk assessment of copper oxide nanoparticles in *Duttaphrynus melanostictus* tadpoles. *Chemosphere* **2023**, *314*, 137754. [CrossRef] [PubMed]
18. Salieri, B.; Righi, S.; Pasteris, A.; Olsen, S.I. Freshwater ecotoxicity characterisation factor for metal oxide nanoparticles: A case study on titanium dioxide nanoparticle. *Sci. Total. Environ.* **2015**, *505*, 494–502. [CrossRef] [PubMed]
19. Matranga, V.; Corsi, I. Toxic effects of engineered nanoparticles in the marine environment: Model organisms and molecular approaches. *Mar. Environ. Res.* **2012**, *76*, 32–40. [CrossRef] [PubMed]

20. Handy, R.D.; Cornelis, G.; Fernandes, T.; Tsyusko, O.; Decho, A.; Sabo-Attwood, T.; Metcalfe, C.; Steevens, J.A.; Klaine, S.J.; Koelmans, A.A.; et al. Ecotoxicity test methods for engineered nanomaterials: Practical experiences and recommendations from the bench. *Environ. Toxicol. Chem.* **2012**, *31*, 15–31. [CrossRef]
21. Kahru, A.; Dubourgui, H.C.; Blinova, I.; Ivask, A.; Kasemets, K. Biotests and biosensors for ecotoxicology of metal oxide nanoparticles: A minireview. *Sensors* **2008**, *8*, 5153–5170. [CrossRef]
22. EU European Union. Commission Regulation No 286/2011 of 10 March 2011 amending, for the purposes of its adaptation to technical and scientific progress, Regulation (EC) No 1272/2008 of the European Parliament and of the Council on classification, labelling and packaging of substances and mixtures. *Off. J. Eur. Union* **2011**. Available online: <https://eur-lex.europa.eu/legal-content/EN/TXT/?uri=CELEX%3A02011R0286-20130701> (accessed on 16 August 2023).
23. ISO 11348-1:2007; Water Quality: Determination of the Inhibitory Effect of Water Samples on the Light Emission of *Vibrio fischeri* (Luminiscent Bacteria Test). Part 1: Method Using Freshly Prepared Bacteria. ISO: Geneva, Switzerland, 2007; p. 23.
24. Mortimer, M.; Kasemets, K.; Heinlaan, M.; Kurvet, I.; Kahru, A. High throughput kinetic *Vibrio fischeri* bioluminescence inhibition assay for study of toxic effects of nanoparticles. *Toxicol. Vitro* **2008**, *22*, 1412–1417. [CrossRef]
25. Lappalainen, J.; Juvonen, R.; Nurmi, J.; Karp, M. Automated color correction method for *Vibrio fischeri* toxicity test. Comparison of standard and kinetic assays. *Chemosphere* **2001**, *45*, 635–641. [CrossRef] [PubMed]
26. ISO 10253; Water Quality—Marine Algal Growth Inhibition Test with *Skeletonema* sp. and *Phaeodactylum tricornutum*. ISO: Geneva, Switzerland, 2016.
27. ASTM E1440-91:2012; Standard Guide for Acute Toxicity Test with the Rotifer *Brachionus*. ASTM: West Conshohocken, PA, USA, 2012.
28. EPA 712-C-96-154; Record Display for the EPA National Library Catalog. U.S. Environmental Protection Agency, Prevention, Pesticides and Toxic Substances: Washington, DC, USA, 1996.
29. Manusadžianas, L.; Grigutyte, R.; Jurkoniene, S.; Karitonas, R.; Sadauskas, K.; Féraud, J.F.; Cotelte, S.; Foucaud, L. Toxicity of zinc oxide nanoparticle suspensions to aquatic biota. In Proceedings of the ISTA-14, International Symposium on Toxicity Assessment, Metz, France, 30 August–4 September 2009.
30. Aruoja, V.; Dubourgui, H.C.; Kasemets, K.; Kahru, A. Toxicity of nanoparticles of CuO, ZnO and TiO₂ to microalgae *Pseudokirchneriella subcapitata*. *Sci. Total Environ.* **2009**, *407*, 1461–1468. [CrossRef]
31. Franklin, N.M.; Rogers, N.J.; Apte, S.C.; Batley, G.E.; Gadd, G.E.; Casey, P.S. Comparative toxicity of nanoparticulate ZnO, bulk ZnO, and ZnCl₂ to a freshwater microalga (*Pseudokirchneriella subcapitata*): The importance of particle solubility. *Environ. Sci. Technol.* **2007**, *41*, 8484–8490. [CrossRef]
32. Pendashte, H.; Shariati, F.; Keshavarz, A.; Ramzanpour, Z. Toxicity of zinc Oxide Nanoparticles to *Chlorella vulgaris* and *Scenedesmus dimorphus* Algae Species. *World J. Fish. Mar. Sci.* **2013**, *5*, 563–570.
33. Wiench, K.; Wohlleben, W.; Hisgen, V.; Radke, K.; Salinas, E.; Zok, S.; Landsiedel, R. Acute and chronic effects of nano- and non-nano-scale TiO₂ and ZnO particles on mobility and reproduction of the freshwater invertebrate *Daphnia magna*. *Chemosphere* **2009**, *76*, 1356–1365. [CrossRef] [PubMed]
34. Zhu, X.; Zhu, L.; Chen, Y.; Tian, S. Acute toxicities of six manufactured nanomaterial suspensions to *Daphnia magna*. *J. Nanopart Res.* **2009**, *11*, 67–75. [CrossRef]
35. Stampoulis, D.; Sinha, S.K.; White, J.C. Assay-dependent phytotoxicity of nanoparticles to plants. *Environ. Sci. Technol.* **2009**, *43*, 9473–9479. [CrossRef]
36. UMN, 2014. University of Minnesota. Available online: <https://extension.umn.edu/micro-and-secondary-macronutrients/zinc-crop-production/> (accessed on 1 July 2020).
37. Manzo, S.; Rocco, A.; Carotenuto, R.; Picione, F.D.L.; Miglietta, M.L.; Rametta, G.; Di Francia, G. Investigation of ZnO nanoparticles' ecotoxicological effects towards different soil organisms. *Environ. Sci. Pollut. Res.* **2011**, *18*, 756–763. [CrossRef]
38. Lee, S.; Kim, S.; Kim, S.; Lee, I. Assessment of phytotoxicity of ZnO NPs on a medicinal plant, *Fagopyrum esculentum*. *Environ. Sci. Pollut. Res. Int.* **2013**, *20*, 848–854. [CrossRef]
39. Hotze, E.M.; Phenrat, T.; Lowry, G.V. Nanoparticle aggregation: Challenges to understanding transport and reactivity in the environment. *J. Environ. Qual.* **2010**, *39*, 1909–1924. [CrossRef]
40. Zafar, H.; Ali, A.; Ali, J.S.; Haq, I.U.; Zia, M. Effect of ZnO Nanoparticles on Brassica nigra Seedlings and Stem Explants: Growth Dynamics and Antioxidative Response. *Front. Plant Sci.* **2016**, *7*. [CrossRef] [PubMed]
41. Jósko, I.; Oleszczuk, P. Influence of soil type and environmental conditions on ZnO, TiO₂ and Ni nanoparticles phytotoxicity. *Chemosphere* **2013**, *92*, 91–99. [CrossRef] [PubMed]

Disclaimer/Publisher's Note: The statements, opinions and data contained in all publications are solely those of the individual author(s) and contributor(s) and not of MDPI and/or the editor(s). MDPI and/or the editor(s) disclaim responsibility for any injury to people or property resulting from any ideas, methods, instructions or products referred to in the content.