

Article

Comparative Experimental Assessment of Pollutant Emission Behavior in Combustion of Untreated and Thermally Treated Solid Biofuels from Spruce Chips and Rapeseed Straw

Jan Malaťák ¹, Jan Velebil ^{2,*}, Jiří Bradna ², Marián Kučera ³, Arkadiusz Gendek ⁴, Monika Aniszewska ⁴ and Tatiana Alexiou Ivanova ⁵

¹ Department of Technological Equipment of Buildings, Faculty of Engineering, Czech University of Life Sciences Prague, Kamýčká 129, 165 00 Prague, Czech Republic; malatak@tf.czu.cz

² Research Institute of Agricultural Engineering, Drnovská 407, 161 01 Prague, Czech Republic; jiri.bradna@vuzt.cz

³ Department of Mechanics, Mechanical Engineering, and Design, Faculty of Technology, Technical University in Zvolen, Ul. T. G. Masaryka 24, 96001 Zvolen, Slovakia; marian.kucera@tuzvo.sk

⁴ Department of Biosystems Engineering, Institute of Mechanical Engineering, Warsaw University of Life Sciences—SGGW, Nowoursynowska 164, 02-787 Warsaw, Poland; arkadiusz_gendek@sggw.edu.pl (A.G.); monika_aniszewska@sggw.edu.pl (M.A.)

⁵ Department of Sustainable Technologies, Faculty of Tropical AgriSciences, Czech University of Life Sciences Prague, Kamýčká 129, 165 00 Prague, Czech Republic; ivanova@ftz.czu.cz

* Correspondence: jan.velebil@vuzt.cz

Abstract: Biomass energy for heating is going to be part of the spectrum of renewable energy sources. However, biomass combustion produces emissions of various pollutants with negative effects at both local and global scales. To reduce some of the locally important pollutant load, thermally treated biomass fuels may offer a partial solution. In this study, two biomass feedstocks, i.e., spruce chips and rapeseed straw, were thermally treated at 300 °C to produce biochars. Subsequently, both original materials and biochars were burned in a 25 kW retort combustion device. In both cases, the biochar showed lower emissions of carbon monoxide and nitrogen oxides, usually almost across the whole range of tested combustion conditions. In total, for the emission production per unit of net calorific value, the spruce biochar showed reductions in CO and NO_x productions of 10.8% and 14.5%, respectively. More importantly, in rapeseed straw biochar, the difference was more pronounced. The total production was reduced by 28% and 42%, again in CO and NO_x emissions, respectively.

Keywords: biomass; biochar; combustion; carbon monoxide; nitrogen oxides; torrefaction; pyrolysis



Citation: Malaťák, J.; Velebil, J.; Bradna, J.; Kučera, M.; Gendek, A.; Aniszewska, M.; Alexiou Ivanova, T. Comparative Experimental Assessment of Pollutant Emission Behavior in Combustion of Untreated and Thermally Treated Solid Biofuels from Spruce Chips and Rapeseed Straw. *Atmosphere* **2024**, *15*, 452. <https://doi.org/10.3390/atmos15040452>

Academic Editor: Kumar Vikrant

Received: 7 February 2024

Revised: 22 March 2024

Accepted: 1 April 2024

Published: 5 April 2024



Copyright: © 2024 by the authors. Licensee MDPI, Basel, Switzerland. This article is an open access article distributed under the terms and conditions of the Creative Commons Attribution (CC BY) license (<https://creativecommons.org/licenses/by/4.0/>).

1. Introduction

The most significant source of greenhouse gas emissions is the burning of coal for the production of electricity [1]. For many years, there has been an ongoing discussion about the extent of the role of biomass as an important renewable energy source, which can often be seen as a CO₂-neutral energy source and is an interesting option for reducing CO₂ emissions [2–4]. The use of biomass for electricity and heat production is going to stay for the foreseeable future, including the heating of residential homes, since it still tends to be the cheapest option. However, for a fuel, being CO₂ neutral is not necessarily good enough. It also needs to be easily and efficiently utilized and it must not produce excessive emissions of pollutants, such as CO, NO_x, and particulate matter, which can by themselves cause damage by contributing to increases in some illnesses [5,6].

Among the most important biomass sources for energy production are wood and herbal biomass [7,8]. When using raw biomass, the presence of elements such as nitrogen, sulfur, and chlorine and the composition of ash-forming elements make it a demanding fuel, even with regard to the production of CO and CO₂ [9]. The emissions of CO, NO_x,

solid particles, and SO_x are then the main problems in the conversion of biomass to energy by combustion [10]. A large body of research has been focused on the analysis of emissions formation and on the optimization of biomass processing for the reduction in, e.g., NO_x emissions [11,12]. In general, NO_x emissions arise from chemically bound fuel nitrogen, which is always present in solid biofuels; on the other hand, CO is a sign of incomplete combustion [13,14]. Nitrogen oxides may be generated by a number of mechanisms and understanding the processes of NO_x formation is important for their reduction [15]. The importance of radical reactions at the flame boundary for the formation of NO_x was shown [16,17]. More significant, however, are NO_x emissions due to the reaction of atmospheric nitrogen at elevated combustion temperatures [18] and with increased amounts of combustion air [19,20]. Jiang et al. [21] investigated the influence of various parameters, such as temperature, composition, and particle size, on the formation of nitrogen oxides upon combustion. The formation of these pollutants depends on the properties of the fuel and on the operational parameters of the combustion equipment [22]. The temperature, combustion, air flow distribution and its amount, residence time, reactor design, fuel elemental composition, and ash content are among the main influencing factors [13]. Studies that dealt with the effects of the excess air factor and temperature showed that temperature has little effect on the formation of NO_x emissions in practice [21,22]. On the other hand, the coefficient of excess air is the most important parameter [23,24]. And generally, the formation of one emission component has a great influence on the formation of other emission components in the flue gas [25].

One option to enhance the usability of biomass is its modification to a value-added product, such as biochar, through various pyrolysis or torrefaction technologies [26]. These types of processing contribute to the decomposition of certain parts of the original material, mainly cellulose and hemicelluloses. This contributes to the reduction in the fiber length and mechanical stability [27,28]. It also brings various positive effects. Treated biomass shows more homogeneous physico-chemical properties compared with raw biomass, which predisposes it to not only energy purposes but it can be used readily as a soil amendment as well [29,30]. There are various pyrolysis technologies for the production of biochar, which can be classified into dry processing methods [31–33] and wet processing methods [34–38]. Furthermore, dry processing, e.g., dry torrefaction, can be used as a pre-treatment before liquefaction processing to obtain liquid biomass-derived products [39]. In general terms, in all pyrolysis methods, volatiles are removed from the biomass, leaving behind a dark brown solid residue with a higher energy density compared with the original material [40,41]. The calorific values of biochar approach those of coal (22 to 23 MJ kg⁻¹) or even exceed them. Since October 2023, the usefulness of thermally treated biomass as a fuel can be evaluated using the international standard ISO 17225-8 [42], which brings specifications for graded thermally treated and densified biomass fuels. A possible advantage of thermally treated biofuels may be the propensity for a cleaner or more controllable combustion process [43].

Although there are a number of reports showing emission parameters of various biomasses and biochars, there is a lack of information comparing the biochar with its source biomass outside of laboratory measurements. To allow for verifying whether biochar may possibly contribute to better local air quality, this study aimed to approximate a real-world scenario of biochar substituting biomass in energy use. This study was based on the hypothesis that thermally treated solid biofuels from wood and herbal biomass would achieve comparable or better emissions upon combustion corresponding to the requirement for biomass combustion. This was tested, first, through establishing the quality of the thermally treated products, and second, by determining the emission-producing behavior of the assessed samples on a combustion device for biomass. The emission concentrations of CO and NO_x were evaluated as a function of the coefficient of excess air and flue gas temperature.

2. Materials and Methods

2.1. Wood Chips

The wood chips were obtained in the region of central Bohemia in the year 2022. The source of wood chips were offcuts from a sawmill from debarked, primarily spruce wood, which is the most typical wood source in the Czech Republic. Therefore, bark was no longer retained on the individual chips. The advantage of this biomass is that it contains a very low portion of inorganic pollution, it has high calorific values, and there are no technical problems with ash during its use. In central Bohemia, the average reported ash content was below 1 % wt. for spruce and pine wood, with a net calorific value of 18.5 MJ kg^{-1} on a dry basis [44].

2.2. Rapeseed Straw

Rapeseed straw was collected in the region of central Bohemia after the rapeseed harvest in 2022. Rapeseed is the most important oil cropseed of the Czech Republic and its share of cultivation area in the Czech Republic is around 80% of all oil crops [45]. After 1989, rapeseed became the most important transformative crop of Czech agriculture, as it replaced the loss of fodder crops and maintains the balance of humus in the soil. Of all major crops, rapeseed leaves the most straw, in the range of $2.8\text{--}4.5 \text{ t ha}^{-1}$, with a gross calorific value reported around 17.36 MJ kg^{-1} [46–48].

2.3. Sample Pre-Treatment

The pre-treatment of wood chips and rapeseed straw samples consisted mainly of creating a suitable form before its energy use. These pretreatments consisted of reducing the fractional composition and creating a pelletized fuel suitable for subsequent pyrolysis processing and energy use. The samples, original and thermally treated, were ground on a laboratory mill to the required particle size and pressed into the form of pellets with a diameter of 6 mm using a granulation press with a flat matrix (Kovo Novák, Citonice, Czech Republic).

2.4. Thermal Treatment

The actual pyrolysis treatment took place on a semi-operational batch pyrolysis reactor TKKA ZLK (PolyComp, Poděbrady, Czech Republic). After weighing the samples into the reactor, atmospheric air was purged with nitrogen gas. The reaction temperature during the pyrolysis treatment was $300 \text{ }^\circ\text{C}$ with a residence time of 60 min. The dry weight of one batch was 15 kg for wood chips and 30 kg for rapeseed straw. An average of 7.10 kg of biochar from spruce chips (mass yield of dry solid biochar 47.33%) and 13.15 kg of biochar from rapeseed straw (mass yield of dry solid biochar 43.54%) were obtained by the pyrolysis treatment. The resulting by-products were condensed and removed for further processing. Only solid biochar was considered in this study.

2.5. Elemental and Proximate Analysis

For the compositional analysis, samples from each material were first ground in a laboratory mill to produce homogenous analytical samples. The non-combustible substances of the fuels, i.e., the ash and the total water content, were determined by incineration at $550 \text{ }^\circ\text{C}$ (ISO 18122 [49]) and drying at $105 \text{ }^\circ\text{C}$ (ISO 18134-3 [50]), respectively, until constant weight. The elements of carbon (C), hydrogen (H), and nitrogen (N) were determined on a CHN analyzer Perkin-Elmer 2400 (PerkinElmer, Inc., Waltham, MA, USA). To determine the chlorine (Cl) and sulfur (S) contents, the samples were burned in an oxygen–hydrogen flame on a Wickbold apparatus. The gross calorific values (GCVs) of the assessed fuel samples were determined in an IKA 2000 bomb calorimeter (IKA-Werke GmbH & Co., KG, Staufen, Germany). The net calorific value (NCV) was determined by calculation according to ISO 1928 [51], for which the results of the elementary analysis of individual biofuel samples were used. All measurements were carried out at least in triplicate.

To determine the emission indicators, the results of elemental analyses were used for the stoichiometric analysis of combustion processes in the diffusion areas of combustion processes. Stoichiometric analysis completed the characterization of these biomass samples. By stoichiometric calculations, the amount of oxygen (and subsequently of combustion air) required for complete combustion of the sample, the amount and composition of flue gas, and the specific gravity of flue gas were determined. The results were used to help evaluate the emission measurement to determine the coefficient of excess air.

2.6. Combustion Tests

As part of the evaluation, all pelletized samples from spruce chips and rapeseed straw, as well as the derived biochars, were combusted on a combustion device Lyčka-AM 24 Lico-therm (Agromechanika v.o.s., Lhenice, Czech Republic) with an automatic fuel supply through a bottom retort (see Figure 1) at a nominal heating output of 25 kW. The goal of this measurement was to determine the behavior of the emission concentrations of CO and NO_x and the flue gas temperature T_{fg} , depending on the excess air coefficient n at the nominal thermal output of the combustion unit. The combustion device was connected to a measurement water loop system, which made it possible to determine the efficiency through the direct method performed according to the standard ČSN 07 0240 [52]. The efficiency could be determined by Equation (1) as the ratio of the energy output defined as heat transferred into the water P_k to the energy input P_p . The energy inputs were mainly the net calorific value of the fuel and the sensible heats of both the fuel and the combustion air.

$$\eta = \frac{P_k}{P_p} \cdot 100 \quad (1)$$

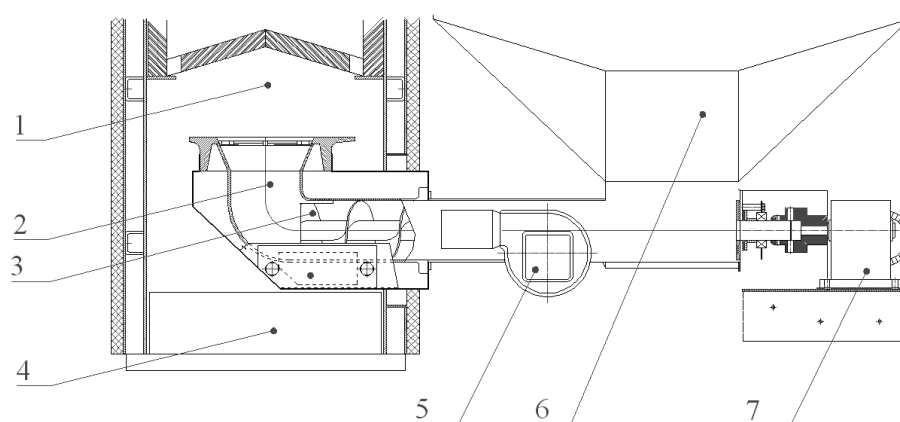

Figure 1. Combustion retort device with bottom fuel supply (1—combustion space; 2—retort; 3—screw feeder; 4—ash tray; 5—combustion fan; 6—fuel bin; 7—motor with gearbox).

Combustion tests were carried out under stabilized conditions at the nominal thermal output of the combustion unit. In the combustion unit (see Figure 1), fuel was fed from the reservoir to the retort with the help of a screw feeder from the bottom. Combustion air was regulated using a fan. Similar devices are commonly used for the heating of family houses. During the measurement, the combustion device was connected to a closed heating loop for the regulation of the thermal output of the device to the nominal heat output. With the help of a screw feeder, fuel samples were fed at a mass flow rate calculated from the composition of the samples (see Table 1). During the measurement, the amount of combustion air was regulated. The ratio between the primary and secondary air was maintained at 3:1. This ratio was maintained at this level based on the known fuel flow rate (see Table 1). The control of the air intake was performed with the help of the coefficient of excess air, which was calculated in real time by a flue gas analyzer. The analyzer was adjusted to each specific

fuel sample based on the elemental composition. Combustion tests were performed for 6 h for each fuel sample.

Table 1. Operating parameters of the combustion unit.

Sample	Gravimetric Flow Rate of Material to the Combustion Unit	Nominal Heat Output	Nominal Combustion Efficiency	Amount of Combustion Air for 1 kg of Fuel at $n = 2.1$
	(kg h ⁻¹)	(kW)	(%)	(m ³ kg ⁻¹)
Spruce pellets	5.72	25	90	9.58
Spruce biochar	3.62	25	90	15.01
Rapeseed straw pellets	6.20	25	90	8.56
Rapeseed straw biochar	3.94	25	90	14.23

2.7. Emission Measurement

The GA-60 device (Madur Polska Sp. z o.o., Zgierz, Poland) was used to determine the emission concentrations. This is a multi-purpose flue gas analyzer. The device employs converters for the analysis of the following components of flue gas: oxygen (O₂), carbon monoxide (CO), nitrogen oxide (NO), nitrogen dioxide (NO₂), and sulfur dioxide (SO₂). The GA-60 device allows for measuring both the ambient (flow) and the flue gas temperature (flue gas). Sensor signals are proportional to the volumetric concentration of the individual components in ppm. The concentrations of the components in dry flue gas were converted to normal gas conditions (i.e., temperature 0 °C and pressure 101.325 kPa) and concentrations in mg m⁻³ at a reference oxygen content in the flue gas of 11 % vol. The analyzer was calibrated by a specialized company and then auto-calibrated before each combustion run. The results of the emission measurements were processed by regression analysis to express the dependence of carbon dioxide and nitrogen oxides on the coefficient of excess air and flue gas temperature. As the simplest appropriate function to explain this dependence, polynomial functions of the second degree were chosen.

3. Results and Discussions

3.1. Fuel Analysis

The pellet samples in their original state had a fairly low water content. The spruce pellet samples had an average of 5.59 % wt. water content. In the spruce biochar, however, the average water content stayed even lower at 1.48 % wt. The rapeseed straw pellets had an average of 5.45 % wt. water content, and after the thermal treatment, it stayed slightly lower at 4.88 % wt. Since the water portion of a fuel is a non-combustible component, which also negatively affects combustion [53], it was necessary to monitor and control the moisture content before combustion tests at a reasonable level [54]. Before the combustion tests, there were no changes in the water content of the monitored samples. Such a low water content will have a positive impact not only on the calorific values, but it is also favorable for both thermal treatment and in combustion [8].

The results of other fuel analyses are shown in Table 2. The average ash content of the original spruce pellets was very low. In general, woody biomass [55] has a very low ash content compared with herbaceous biomass [56]. Typically, the amount of ash is determined by the amount of silicon and potassium, which are low in the stem wood, but higher in the bark, leaves, and living tissues of a tree [57]. After the thermal treatment, there was a twofold increase in the amount of ash. This increased amount of ash was still within the range, when the removal of solid residue after combustion did not pose a large problem. In the samples of the pellets from rapeseed straw, however, the ash amount was ten times greater than in the spruce pellet samples. The content of ash was then further elevated during the pyrolysis treatment. A large amount of ash causes an increase in particulate emissions [58]. The emissions of solid particles, however, were not evaluated

in this study. An increased amount of ash creates technical problems for removing ash from the combustion chamber [59]; furthermore, solid deposits can form in the combustion chamber [60]. Naturally, ash, as a non-combustible part of the fuel, reduces both the gross and net calorific values.

Table 2. Proximate composition, calorific values, and main element contents of tested materials in the dry state. The uncertainty is expressed by the standard deviation.

Sample	Ash (% wt.)	GCV (MJ kg ⁻¹)	NCV (MJ kg ⁻¹)	C (% wt.)	H (% wt.)	N (% wt.)	S (% wt.)	O (% wt.)	Cl (% wt.)
Spruce pellets	0.55 (±0.02)	18.65 (±0.01)	17.49	51.31 (±0.14)	5.32 (±0.04)	0.10 (±0.01)	0.03 (±0.001)	42.67	0.02 (±0.001)
Spruce biochar	1.15 (±0.02)	28.51 (±0.01)	27.63	75.65 (±0.24)	4.02 (±0.03)	0.10 (±0.01)	0.03 (±0.001)	19.01	0.04 (±0.001)
Rapeseed straw pellets	5.11 (±0.03)	17.25 (±0.01)	16.12	46.24 (±0.11)	5.18 (±0.05)	0.76 (±0.02)	0.24 (±0.002)	42.24	0.23 (±0.01)
Rapeseed straw biochar	13.95 (±0.04)	25.93 (±0.01)	25.36	71.88 (±0.15)	2.61 (±0.03)	1.43 (±0.03)	0.46 (±0.003)	9.30	0.37 (±0.01)

As for the elemental composition, the carbon contents in untreated materials corresponded to values for the same types of biomasses, i.e., woody and herbaceous, reported in other sources [55]. In the diffusion-controlled combustion, carbon burns completely to produce carbon dioxide [61]. In the opposite case, under an insufficient supply of oxygen, carbon turns partly into carbon monoxide in the flue gas, as well as creating heat losses [62]. The thermal treatment significantly increased the proportion of carbon in both the pellet samples to values above 70 % wt., thereby increasing the calorific values. Such a high increase in the carbon content in biochar was also observed with similar biomass [63].

The contents of other biogenic elements, i.e., hydrogen, nitrogen, and sulfur, in the samples of spruce and rapeseed pellets corresponded to similar biofuels [44,55]. After the thermal treatment, the contents of nitrogen and sulfur increased substantially in the samples of rapeseed straw, i.e., by 53.1% and 52.2%, respectively. Compared with fossil fuels [64], however, the amount of sulfur was still quite low. Increased nitrogen and sulfur concentrations in rapeseed straw pellet samples may be a reason for the increased emissions of nitrogen and sulfur oxides [65]. In this study, the SO_x emissions were not evaluated due to the very low content in spruce pellets. Indeed, most biomass fuels have a low sulfur concentration (0.01–0.5 % wt.), and therefore, very low concentrations of SO₂ are emitted [66]. In particular, woody biomass tends to have a several times lower concentration of sulfur compared with herbal biomass [56]. During pyrolysis, part of this sulfur content is released into gaseous and liquid products, as was reported for woody [67] and herbal biomasses [68,69]. It can then be hypothesized that SO₂ emissions will be reduced [66].

From a certain viewpoint, oxygen is a ballast component in a fuel since it inevitably lowers the maximum possible energy density. The average percentage of oxygen in raw biofuel samples was above 42 % wt. in the dry state. After the pyrolysis treatment, this was reduced by 55.4% in samples from spruce pellets and even more significantly by 77.9% in samples from rapeseed straw. Similar results were reported before [8,70,71]. This reduction in oxygen increased the proportions of other elements in the fuel, and thus, contributed to a significant increase in calorific values.

Compared with the chlorine content in the spruce pellets, where it was only 0.02 % wt., the chlorine content in all types of herbal biomass tends to be higher [55,72]. In the rapeseed straw samples, the values were about ten times higher, and after the pyrolysis treatment, they increased by another 60%. Based on these results, it could also be concluded that rapeseed straw and its biochar would be the more difficult fuel during combustion.

To evaluate the biofuels for possible commercial use, they can be classified according to the most applicable international standards. In the case of spruce wood pellets, for all

tested parameters, they met the criteria for the A1 class according to the ISO 17225-2 [73]. Rapeseed straw pellets fell under ISO 17225-6 [74] as a non-woody material. Given the content of sulfur and chlorine, the material tested fell under class B; however, all other decisive parameters, i.e., ash and nitrogen content and net calorific value met the class A criteria. For thermally treated fuels, the ISO 17225-8 [42] applies. Since in thermally treated biomass, a substantial increase in calorific value can be expected, many parameters are related to the net calorific value. For the tested materials, these values are given in Table 3. For biochars, decisive parameters are in bold. For chemically untreated woody biomass, the spruce biochar easily met the criteria for the TW1 class. For non-woody thermally treated biomass, the rapeseed straw biochar failed to meet the TA2 class criteria due to having too high sulfur and chlorine content. The ash content was also quite high, which would leave it in TA2 if it met other criteria.

Table 3. Proximate and elemental compositions in the dry state reported in units of mass per unit of net calorific value.

Sample	Ash (g/MJ)	C (g/MJ)	H (g/MJ)	N (g/MJ)	S (g/MJ)	O (g/MJ)	Cl (g/MJ)
Spruce pellets	0.31	29.34	3.04	0.06	0.02	24.40	0.01
Spruce biochar	0.42	27.38	1.45	0.04	0.01	6.88	0.01
Rapeseed straw pellets	3.17	28.68	3.21	0.47	0.15	26.2	0.14
Rapeseed straw biochar	5.50	28.34	1.03	0.56	0.18	3.67	0.15

3.2. Emission Concentrations of Carbon Monoxide as a Function of the Coefficient of Excess Air and the Flue Gas Temperature

For the spruce pellets, the concentrations of carbon monoxide showed a steep decrease as the coefficient of excess air increased from 1.96 to 2.38 (see Figure 2a). The lowest carbon monoxide emission concentrations of 400 mg m^{-3} occurred at an excess air factor of 2.38. From this minimum, there was a slight increase. Overall, for the spruce pellets, the nominal heat output of the unit was regulated in the range of excess air factor from 1.96 to 2.45, ranging from $158 \text{ }^\circ\text{C}$ to $173 \text{ }^\circ\text{C}$, respectively. The spread in carbon monoxide emission concentrations was quite wide in the range of 400 to 2240 mg m^{-3} . The highest emissions were produced at the highest temperature of $173 \text{ }^\circ\text{C}$ (see Figure 2b), though normally, carbon monoxide production decreases with increasing combustion temperature to a limit when the combustion process has an optimal amount of combustion air [75,76]. The optimal excess of air during combustion is when the lowest concentrations of carbon monoxide are achieved at the nominal heat output [77]. Below the optimal excess of air, the combustion temperature can increase [78]; however, it is accompanied by rapidly increasing CO emissions [79]. This phenomenon usually occurs during the start and extinction of the combustion process [53,80]. On the other hand, high concentrations of carbon monoxide can occur with a larger ratio of excess air, when the amount of oxygen is not the limiting factor for complete combustion. A large surplus of combustion air lowers the combustion temperature [14,81], which, in the present case, also resulted in high CO concentrations for untreated rapeseed straw and its biochar.

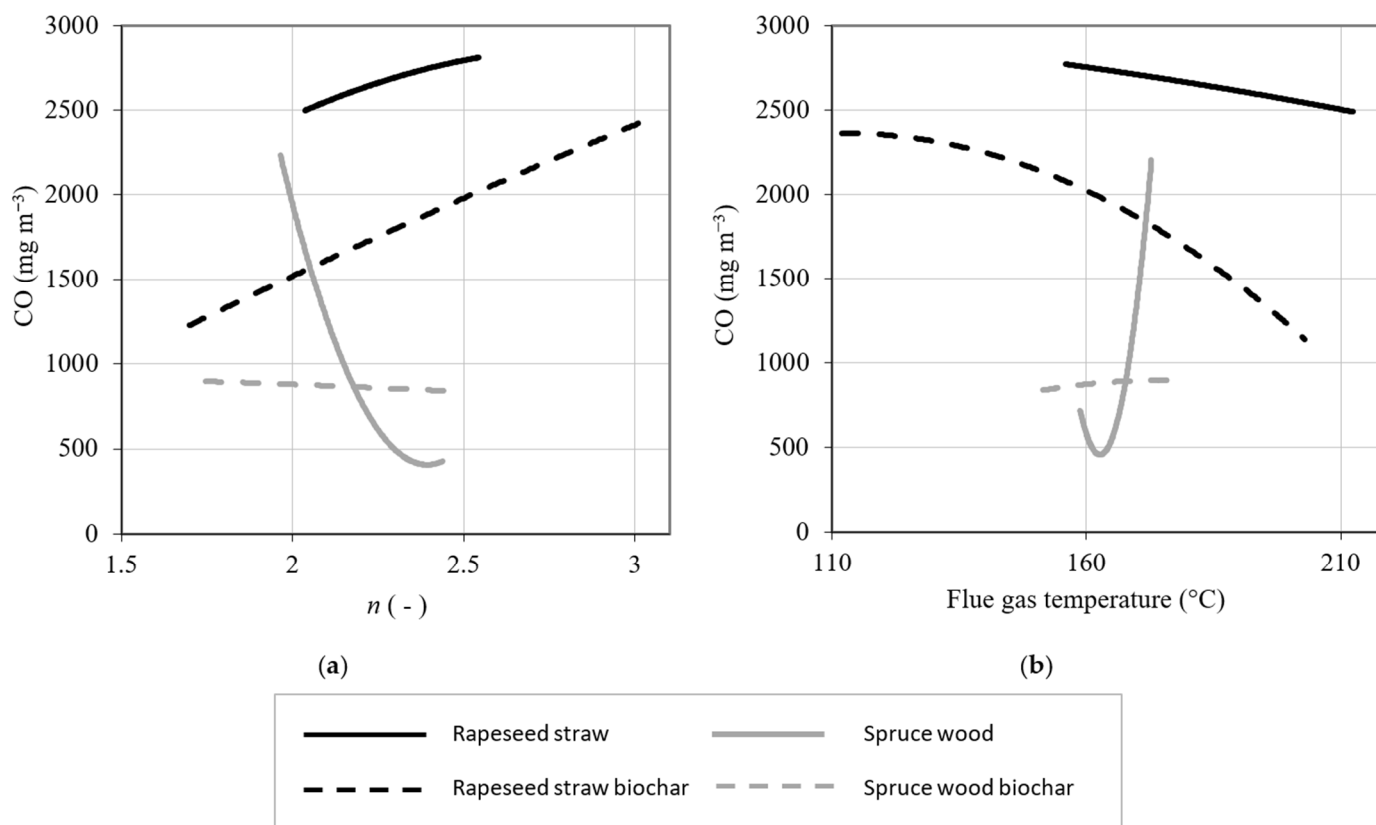

Figure 2. CO emission concentrations as functions of (a) the coefficient of excess air and (b) flue gas temperature.

In this case, having a sufficient amount of combustion air had a clearly positive effect on the reduction in the carbon monoxide production. Very similar results were achieved in other studies [8,80], where, on the one hand, the emission concentration of carbon monoxide decreased with an increasing coefficient of excess, but at the same time, with increasing temperature, there was an increase in the emission production. This was because as the coefficient of excess air increases, the temperature in the combustion space cooled, and this led to a cooling of the combustion temperature, and thus, a reduction in the temperature of the flue gases. When optimizing the combustion process for this fuel, the optimal excess air coefficient would be around the value 2.38, while the optimal flue gas temperature was around 163 °C.

For the spruce biochar samples, combustion was regulated in the range of excess air coefficient from 1.74 to 2.46, while the temperature ranged from 152 °C to 177 °C. There was a gradual decrease in CO emissions from 900 to 850 mg m⁻³ through the whole range, or conversely, an increase in flue gas temperature led to a slight increase in the CO emissions. Compared with untreated samples of spruce pellets, the spread of emission concentrations was much smaller. Similar results were found in the reduction in emission concentrations during the incineration of forestry waste and agro-waste [8,22,82,83].

The rapeseed straw pellets achieved the highest emission concentrations of carbon monoxide of all tested materials. The nominal operation output could be regulated in the range of excess air factor from 2.03 to 2.54, where the flue gas temperature ranged from 156 to 213 °C. In the whole range, there was a gradual increase in the CO concentrations from 2380 to 2810 mg m⁻³ with the excess air factor, along with decreasing temperature. Generally, in order to reduce CO emissions, it is necessary to increase the combustion temperatures or prolong the retention of flue gas at high temperatures. High emission concentrations of CO alongside a high coefficient of excess air were shown during the burning of some herbal biomasses [22], energy crops [83], and some agricultural wastes [82].

To further reduce CO emissions, this would require a redesign of the combustion device to optimize the mixing of combustion air with fuel.

In the rapeseed straw biochar, however, a significant reduction in CO emissions was achieved. This sample was combusted in the range of the excess air coefficient from 1.7 to 3.04, with a gradual increase in CO emission concentrations from 1220 to 2450 mg m^{-3} . Conversely, they decreased with higher temperature, which was in the range of 112 to 204 $^{\circ}\text{C}$. To optimize the combustion in a particular device to reach the lowest possible CO emissions, it is necessary to maintain an optimal value of the excess air factor [75,77]. In the case of the rapeseed straw biochar pellets, the optimal coefficient would be a low value of around 2.

3.3. Emission Concentrations of Nitrogen Oxides as a Function of the Coefficient of Excess Air and the Flue Gas Temperature

The emission concentrations of nitrogen oxides in samples of the spruce pellets showed a steady decrease with an increasing coefficient of excess air from 1.74 to 2.43 (see Figure 3a). For the increasing flue gas temperature from 158 to 165 $^{\circ}\text{C}$, there was an initial slight decrease (see Figure 3b). Above this temperature, there was a gradual increase in the emission concentrations of nitrogen oxides up to the maximum measured value of 94 mg m^{-3} . The lowest emission concentrations of nitrogen oxides, i.e., 79 mg m^{-3} , was measured at the highest recorded excess air factor of 2.43.

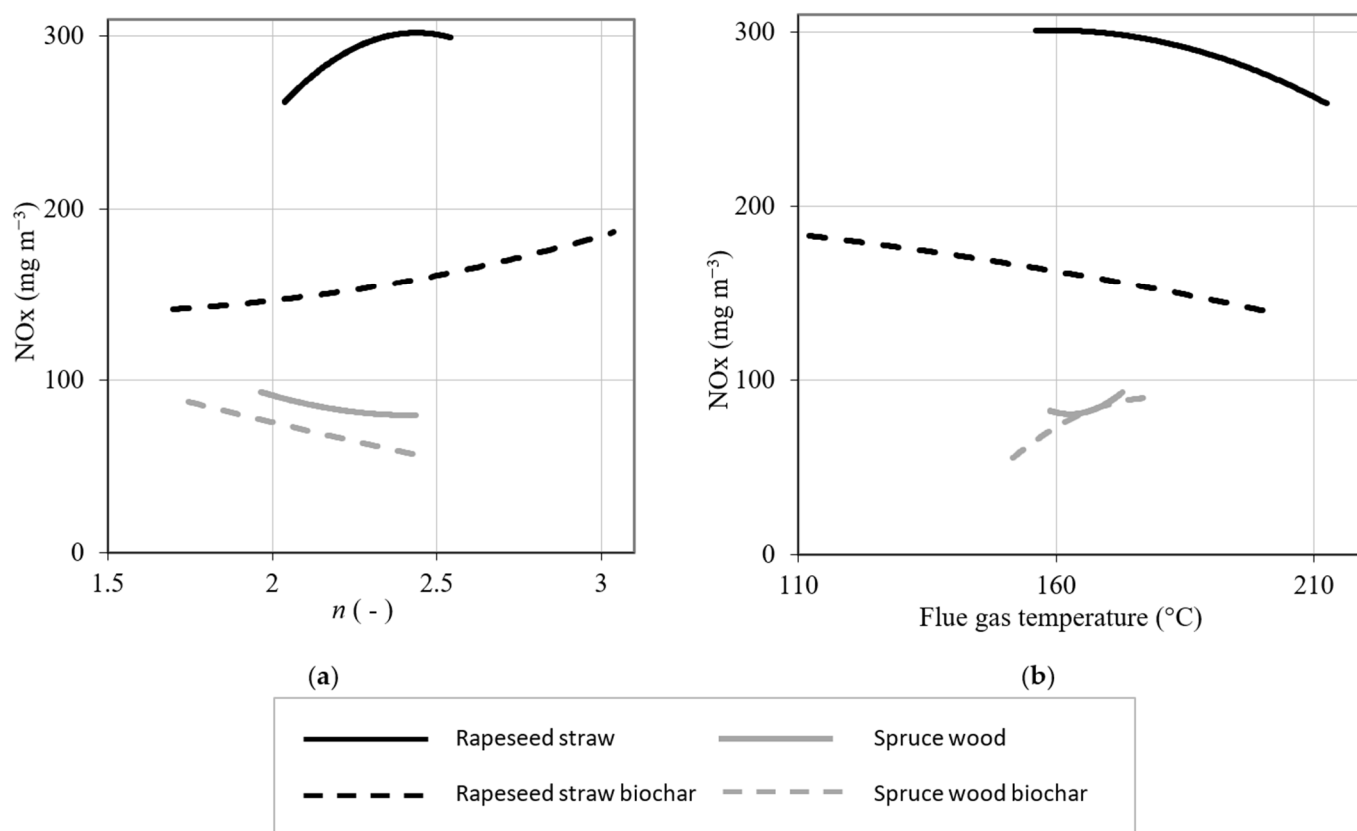

Figure 3. NOx emission concentrations as functions of (a) the coefficient of excess air and (b) flue gas temperature.

The combustion of thermally treated spruce samples in the range of excess air coefficient from 1.74 to 2.43 proceeded similarly to untreated samples. There was a gradual decrease in the emission concentrations of nitrogen oxides from 89 to 54 mg m^{-3} with the increase in excess air factor. Depending on the flue gas temperature, ranging from 152 to 178 $^{\circ}\text{C}$, there was a monotonous gradual increase in the emission concentrations. The

increasing combustion temperature, which determined the temperature of the flue gas, had a greater effect on the increase in NO_x emissions than the coefficient of excess air. Similar results were also achieved on other combustion devices [46], or when burning spruce wood [18] or wood pellets [19]. Overall, the emission concentration of nitrogen oxides during the combustion of the pyrolytically processed spruce pellets decreased compared with untreated samples of spruce pellets. The rapeseed straw pellets initially showed a gradually increasing NO_x concentration dependence on the coefficient of excess air until the value of 2.52, from the minimum of 260 mg m⁻³ to the maximum concentration 302 mg m⁻³. Above this ratio, the NO_x concentration fell slightly to the final value of 298 mg m⁻³. The rapeseed straw had several times higher nitrogen content compared with the spruce wood. Therefore, it was expected that fuel nitrogen would contribute significantly to NO_x emission [84]. However, high amounts of combustion air over the stoichiometric ratio can play a role [8,77]. This was also reflected in reality since the lowest emission concentration of nitrogen oxides, i.e., 260 mg m⁻³, was achieved at the lowest excess air coefficient while at the highest temperature. This was also evidenced with combustion on a different combustion device [46], or during the combustion of spruce wood [18].

Compared with the untreated rapeseed straw, the biochar again showed a reduction in the emission concentrations of nitrogen oxides during the combustion. In the range of the excess air coefficient from 1.7 to 3.04, corresponding to the flue gas temperature decreasing from 204 to 112 °C, there was a gradual increase in the NO_x emission concentrations from 141 to 188 mg m⁻³. Here, again, it was optimal to keep the coefficient of excess air at low values. As the temperature of the flue gas increased, there was a gradual reduction in the emission concentrations of nitrogen oxides during the combustion of pyrolytically treated samples of rapeseed straw pellets. In the flue gas temperature range from 112 to 204 °C, there was a gradual decrease in the carbon monoxide emission concentrations in the range from 188 to 141 mg m⁻³. In order to optimize the combustion equipment and reduce the emission concentrations of nitrogen oxides, it is important to look at the combustion process not only from the point of view of flue gas temperatures but also from the point of view of the coefficient of excess air and the amount of nitrogen contained in the fuel itself.

Fuel-bound nitrogen is not the only cause of NO_x evolution during combustion, as shown in rice straw and pine sawdust [85]. With an increasing combustion temperature and amount of combustion air, an increase in NO_x production was shown in both herbaceous biomass (grasses and straws) [86] and woody biomass [80].

3.4. Comparison of Emissions Per Unit of Heat Energy

To decide which fuel brings the least amount of unwanted emissions, it is not enough to only compare normalized emission concentrations. Since the calorific values and flue gas volume do differ between various fuels, the comparison needs to be related to a unit of useful energy, which is the net calorific value for most uses. Table 4 lists the average emissions production throughout the combustion test for each of the tested materials and converts them into values in grams per 1 GJ of NCV. It can be seen from Table 4 that the biochars achieved lower overall emissions production in comparison with the original biomass feedstocks. In the spruce biochar, when compared with untreated material, there were reductions in the emission concentrations of CO and NO_x of 12% and 8.3%, respectively. In total emissions per unit of energy, the reduction was even higher, i.e., 10.8% and 14.5%, respectively. More importantly, in the rapeseed straw biochar, the difference was more pronounced. Compared with the untreated straw, the emission concentrations were, on average, lower by 31% and 45% for CO and NO_x, respectively. In total production, it was a reduction of 28% and 42%, again for CO and NO_x emissions, respectively.

Table 4. Average production of CO and NOx emissions related to 1 GJ of net calorific value.

Sample	CO	NOx	CO	NOx
	(mg m ⁻³)	(mg m ⁻³)	(g/GJ)	(g/GJ)
Spruce pellets	1000	84	550	46
Spruce biochar	880	77	470	41
Rapeseed straw pellets	2640	288	1410	153
Rapeseed straw biochar	1820	158	1010	88

The emissions of the spruce wood and its biochar were, on average, significantly lower than for the rapeseed straw. This could be expected since wood tends to be a good fuel, especially if it has very low ash and nitrogen contents. In particular, spruce wood was shown to produce better emissions compared with other woody materials, e.g., willow in PM and NOx concentrations [87].

Thermally treated biomass was shown to have at least somewhat lower emission concentrations, e.g., in olive residue torrefied at 275 °C [43] or can be helpful in fuel blends with coal [43,88].

4. Conclusions

To establish the benefit of thermally treated biomass for combustion, two materials, i.e., spruce wood chips and rapeseed straw, were converted into biochar at 300 °C. The biochars had better fuel properties, mainly in terms of their considerably higher net calorific value. Yet, the biochar from the rapeseed straw failed to meet the criteria for its corresponding category of thermally treated biofuels according to ISO 17225-8. The original biomasses and the biochars were combusted on a combustion device with a bottom feed of fuel at a nominal heat output of 25 kW. The biochars showed lower emissions of carbon monoxide and nitrogen oxides. In the spruce biochar, the reduction in emissions per 1 GJ of net calorific value was 10.8% and 14.5% for CO and NOx, respectively. For rapeseed straw biochar, these reductions were 28% and 42% compared with the untreated biomass. It is also important to note that while spruce achieved the lowest CO emissions under optimal excess air, in the spruce biochar, the CO concentrations were stabilized over a much wider range of combustion conditions. This could be the case for other woody biofuels, which would make this behavior very beneficial in favor of thermally treated fuels.

It should not be forgotten that compared with untreated biofuels, biochars have other beneficial properties. For a given amount of energy, they weigh less, which also means lower transportation costs. For sufficiently high treatment temperatures they are more hydrophobic and resistant to biological decay compared with untreated biomass.

In order to demonstrate whether thermally treated biofuels can be a viable choice for residential use, it will be necessary to perform a more comprehensive review. For future studies, it will be important to assess not only the behavior in energy use and storage or analyze the economic feasibility but also include other environmental effects in the consideration, such as cleaner combustion.

Author Contributions: Conceptualization, J.M. and T.A.I.; formal analysis, J.M., M.K. and M.A.; methodology, J.M., J.V., J.B., A.G., M.A. and T.A.I.; project administration, J.M.; resources, J.M., J.V. and A.G.; visualization, J.V. and A.G.; writing—original draft, J.M. and J.V.; writing—review and editing, J.B., M.K., A.G., M.A. and T.A.I. All authors have read and agreed to the published version of the manuscript.

Funding: This study was supported within the long-term conceptual development of the Research Institute of Agricultural Engineering p.r.i. no. MZE-RO0623.

Institutional Review Board Statement: Not applicable.

Informed Consent Statement: Not applicable.

Data Availability Statement: The datasets used during the current study are available from the corresponding author upon reasonable request.

Conflicts of Interest: The authors declare no conflicts of interest. The funders had no role in the design of the study; in the collection, analyses, or interpretation of data; in the writing of the manuscript; or in the decision to publish the results.

References

- Saidur, R.; Abdelaziz, E.A.; Demirbas, A.; Hossain, M.S.; Mekhilef, S. A Review on Biomass as a Fuel for Boilers. *Renew. Sustain. Energy Rev.* **2011**, *15*, 2262–2289. [[CrossRef](#)]
- Mcllveen-Wright, D.R.; Huang, Y.; Rezvani, S.; Mondol, J.D.; Redpath, D.; Anderson, M.; Hewitt, N.J.; Williams, B.C. A Techno-Economic Assessment of the Reduction of Carbon Dioxide Emissions through the Use of Biomass Co-Combustion. *Fuel* **2011**, *90*, 11–18. [[CrossRef](#)]
- Khan, M.A.H.; Bonifacio, S.; Clowes, J.; Foulds, A.; Holland, R.; Matthews, J.C.; Percival, C.J.; Shallcross, D.E. Investigation of Biofuel as a Potential Renewable Energy Source. *Atmosphere* **2021**, *12*, 1289. [[CrossRef](#)]
- Monjardino, J.; Dias, L.; Fortes, P.; Tente, H.; Ferreira, F.; Seixas, J. Carbon Neutrality Pathways Effects on Air Pollutant Emissions: The Portuguese Case. *Atmosphere* **2021**, *12*, 324. [[CrossRef](#)]
- Tarin-Carrasco, P.; Im, U.; Geels, C.; Palacios-Peña, L.; Jiménez-Guerrero, P. Reducing Future Air-Pollution-Related Premature Mortality over Europe by Mitigating Emissions from the Energy Sector: Assessing an 80% Renewable Energies Scenario. *Atmos. Chem. Phys.* **2022**, *22*, 3945–3965. [[CrossRef](#)]
- de Albuquerque, Y.L.; Berger, E.; Li, C.; Pardo, M.; George, C.; Rudich, Y.; Géloën, A. The Toxic Effect of Water-Soluble Particulate Pollutants from Biomass Burning on Alveolar Lung Cells. *Atmosphere* **2021**, *12*, 1023. [[CrossRef](#)]
- Schimel, D.S.; House, J.I.; Hibbard, K.A.; Bousquet, P.; Ciais, P.; Peylin, P.; Braswell, B.H.; Apps, M.J.; Baker, D.; Bondeau, A.; et al. Recent Patterns and Mechanisms of Carbon Exchange by Terrestrial Ecosystems. *Nature* **2001**, *414*, 169–172. [[CrossRef](#)] [[PubMed](#)]
- Malat'ák, J.; Jankovský, M.; Malat'áková, J.; Velebil, J.; Gendek, A.; Aniszewska, M. Substituting Solid Fossil Fuels with Torrefied Timber Products. *Materials* **2023**, *16*, 7569. [[CrossRef](#)] [[PubMed](#)]
- Houshfar, E.; Wang, L.; Vähä-Savo, N.; Brink, A.; Løvås, T. Characterisation of CO/NO/SO₂ Emission and Ash-Forming Elements from the Combustion and Pyrolysis Process. *Clean Technol. Environ. Policy* **2014**, *16*, 1339–1351. [[CrossRef](#)]
- Čuček, L.; Klemeš, J.J.; Kravanja, Z. Carbon and Nitrogen Trade-Offs in Biomass Energy Production. *Clean Technol. Environ. Policy* **2012**, *14*, 389–397. [[CrossRef](#)]
- Malat'ák, J.; Gendek, A.; Aniszewska, M.; Velebil, J. Emissions from Combustion of Renewable Solid Biofuels from Coniferous Tree Cones. *Fuel* **2020**, *276*, 118001. [[CrossRef](#)]
- Barmina, I.; Lickrastina, A.; Zake, M.; Arshanitsa, A.; Solodovnik, V.; Telisheva, G. Effect of Main Characteristics of Pelletized Renewable Energy Resources on Combustion Characteristics and Heat Energy Production. *Chem. Eng.* **2012**, *29*, 901–906.
- Glarborg, P.; Jensen, A.D.; Johnsson, J.E. Fuel Nitrogen Conversion in Solid Fuel Fired Systems. *Prog. Energy Combust. Sci.* **2003**, *29*, 89–113. [[CrossRef](#)]
- Gürdil, G.; Selvi, K.; Malat'ák, J.; Pinar, Y. Biomass Utilization for Thermal Energy. *Ama Agric. Mech. Asia Afr. Lat. Am.* **2009**, *40*, 80–85.
- Glarborg, P.; Miller, J.A.; Ruscic, B.; Klippenstein, S.J. Modeling Nitrogen Chemistry in Combustion. *Prog. Energy Combust. Sci.* **2018**, *67*, 31–68. [[CrossRef](#)]
- Goos, E.; Sickfeld, C.; Mauß, F.; Seidel, L.; Ruscic, B.; Burcat, A.; Zeuch, T. Prompt NO Formation in Flames: The Influence of NCN Thermochemistry. *Proc. Combust. Inst.* **2013**, *34*, 657–666. [[CrossRef](#)]
- Harding, L.B.; Klippenstein, S.J.; Miller, J.A. Kinetics of CH + N₂ Revisited with Multireference Methods. *J. Phys. Chem. A* **2008**, *112*, 522–532. [[CrossRef](#)]
- Winter, F.; Wartha, C.; Hofbauer, H. NO and N₂O Formation during the Combustion of Wood, Straw, Malt Waste and Peat. *Bioresour. Technol.* **1999**, *70*, 39–49. [[CrossRef](#)]
- Liu, H.; Chaney, J.; Li, J.; Sun, C. Control of NO_x Emissions of a Domestic/Small-Scale Biomass Pellet Boiler by Air Staging. *Fuel* **2013**, *103*, 792–798. [[CrossRef](#)]
- Bai, J.; Yu, C.; Li, L.; Wu, P.; Luo, Z.; Ni, M. Experimental Study on the NO and N₂O Formation Characteristics during Biomass Combustion. *Energy Fuels* **2012**, *27*, 515–522. [[CrossRef](#)]
- Jiang, X.; Huang, X.; Liu, J.; Han, X. NO_x Emission of Fine- and Superfine- Pulverized Coal Combustion in O₂/CO₂ Atmosphere. *Energy Fuels* **2010**, *24*, 6307–6313. [[CrossRef](#)]
- Malat'ák, J.; Velebil, J.; Bradna, J.; Gendek, A.; Tamelová, B. Evaluation of CO and NO_x Emissions in Real-Life Operating Conditions of Herbaceous Biomass Briquettes Combustion. *Acta Technol. Agric.* **2020**, *23*, 53–59.
- Houshfar, E.; Skreiberg, Ø.; Løvås, T.; Todorović, D.; Sørum, L. Effect of Excess Air Ratio and Temperature on NO_x Emission from Grate Combustion of Biomass in the Staged Air Combustion Scenario. *Energy Fuels* **2011**, *25*, 4643–4654. [[CrossRef](#)]
- Malat'ák, J.; Jevic, P.; Gürdil, G.; Selvi, K. Biomass Heat-Emission Characteristics of Energy Plants. *Ama Agric. Mech. Asia Afr. Lat. Am.* **2008**, *39*, 9–13.

25. Wei, X.; Schnell, U.; Han, X.; Hein, K.R.G. Interactions of CO, HCl, and SO_x in Pulverised Coal Flames. *Fuel* **2004**, *83*, 1227–1233. [[CrossRef](#)]
26. Li, J.; Brzdekiewicz, A.; Yang, W.; Blasiak, W. Co-Firing Based on Biomass Torrefaction in a Pulverized Coal Boiler with Aim of 100% Fuel Switching. *Appl. Energy* **2012**, *99*, 344–354. [[CrossRef](#)]
27. Phanphanich, M.; Mani, S. Impact of Torrefaction on the Grindability and Fuel Characteristics of Forest Biomass. *Bioresour. Technol.* **2011**, *102*, 1246–1253. [[CrossRef](#)] [[PubMed](#)]
28. Repellin, V.; Govin, A.; Rolland, M.; Guyonnet, R. Energy Requirement for Fine Grinding of Torrefied Wood. *Biomass Bioenergy* **2010**, *34*, 923–930. [[CrossRef](#)]
29. Jeníček, L.; Tunklová, B.; Malat'ák, J.; Velebil, J.; Malat'áková, J.; Neškudla, M.; Hnilička, F. The Impact of Nutshell Biochar on the Environment as an Alternative Fuel or as a Soil Amendment. *Materials* **2023**, *16*, 2074. [[CrossRef](#)]
30. Lin, F.; Wang, H.; Shaghaleh, H.; Ali Adam Hamad, A.; Zhang, Y.; Yang, B.; Alhaj Hamoud, Y. Effects of Biochar Amendment on N₂O Emissions from Soils with Different PH Levels. *Atmosphere* **2024**, *15*, 68. [[CrossRef](#)]
31. Medic, D.; Darr, M.; Shah, A.; Potter, B.; Zimmerman, J. Effects of Torrefaction Process Parameters on Biomass Feedstock Upgrading. *Fuel* **2012**, *91*, 147–154. [[CrossRef](#)]
32. Pimchuai, A.; Dutta, A.; Basu, P. Torrefaction of Agriculture Residue To Enhance Combustible Properties. *Energy Fuels* **2010**, *24*, 4638–4645. [[CrossRef](#)]
33. Deng, J.; Wang, G.J.; Kuang, J.H.; Zhang, Y.L.; Luo, Y.H. Pretreatment of Agricultural Residues for Co-Gasification via Torrefaction. *J. Anal. Appl. Pyrolysis* **2009**, *86*, 331–337. [[CrossRef](#)]
34. Hoekman, S.K.; Broch, A.; Robbins, C. Hydrothermal Carbonization (HTC) of Lignocellulosic Biomass. *Energy Fuels* **2011**, *25*, 1802–1810. [[CrossRef](#)]
35. Yan, W.; Hastings, J.T.; Acharjee, T.C.; Coronella, C.J.; Vásquez, V.R. Mass and Energy Balances of Wet Torrefaction of Lignocellulosic Biomass. *Energy Fuels* **2010**, *24*, 4738–4742. [[CrossRef](#)]
36. Malat'ák, J.; Dlabaja, T. Hydrothermal Carbonization of Kitchen Waste. *Res. Agric. Eng.* **2016**, *62*, 64–72. [[CrossRef](#)]
37. Acharya, B.; Dutta, A.; Minaret, J. Review on Comparative Study of Dry and Wet Torrefaction. *Sustain. Energy Technol. Assess.* **2015**, *12*, 26–37. [[CrossRef](#)]
38. Aguado, R.; Cuevas, M.; Pérez-Villarejo, L.; Martínez-Cartas, M.L.; Sánchez, S. Upgrading Almond-Tree Pruning as a Biofuel via Wet Torrefaction. *Renew Energy* **2020**, *145*, 2091–2100. [[CrossRef](#)]
39. Sarvaramini, A.; Assima, G.P.; Beaudoin, G.; Larachi, F. Biomass Torrefaction and CO₂ Capture Using Mining Wastes—A New Approach for Reducing Greenhouse Gas Emissions of Co-Firing Plants. *Fuel* **2014**, *115*, 749–757. [[CrossRef](#)]
40. Zwart, R.W.R.; Boerrigter, H.; van der Drift, A. The Impact of Biomass Pretreatment on the Feasibility of Overseas Biomass Conversion to Fischer–Tropsch Products. *Energy Fuels* **2006**, *20*, 2192–2197. [[CrossRef](#)]
41. Prins, M.J.; Ptasinski, K.J.; Janssen, F.J.J.G. More Efficient Biomass Gasification via Torrefaction. *Energy* **2006**, *31*, 3458–3470. [[CrossRef](#)]
42. ISO 17225-8:2023; Solid Biofuels—Fuel Specifications and Classes—Part 8: Graded Thermally Treated and Densified Biomass Fuels for Commercial and Industrial Use. International Organization for Standardization: Geneva, Switzerland, 2023.
43. Magalhaes, D.; Kazanc, F. Influence of Biomass Thermal Pre-Treatment on the Particulate Matter Formation during Pulverized Co-Combustion with Lignite Coal. *Fuel* **2022**, *308*, 122027. [[CrossRef](#)]
44. Malat'áková, J.; Jankovský, M.; Malat'ák, J.; Velebil, J.; Tamelová, B.; Gendek, A.; Aniszewska, M. Evaluation of Small-Scale Gasification for CHP for Wood from Salvage Logging in the Czech Republic. *Forests* **2021**, *12*, 1448. [[CrossRef](#)]
45. Ministry of Agriculture of Czech Republic. *Situáční a Výchledová Zpráva Olejniný (Situation and Outlook Report—Oil Crops)*; Ministry of Agriculture: Prague, Czech Republic, 2022.
46. Bradna, J.; Malat'ák, J.; Velebil, J. Impact of Differences in Combustion Conditions of Rape Straw on the Amount of Flue Gases and Fly Ash Properties. *Agron. Res.* **2017**, *15*, 649–657.
47. Havránek, F.; Pavliš, J.; Hučko, B.; Czudek, R. *Alternative Utilisation of Agricultural Land Scientific Monograph*; Rembrandt: Prague, Czech Republic, 2007; ISBN 978-80-902617-6-1.
48. Lewandowski, I.; Weger, J.; van Hooijdonk, A.; Havlickova, K.; van Dam, J.; Faaij, A. The Potential Biomass for Energy Production in the Czech Republic. *Biomass Bioenergy* **2006**, *30*, 405–421. [[CrossRef](#)]
49. ISO 18122:2022; Solid Biofuels—Determination of Ash Content. International Organization for Standardization: Geneva, Switzerland, 2022; p. 6.
50. EN ISO 18134-3:2023; Solid Biofuels—Determination of Moisture Content—Oven Dry Method Part 3: Moisture in General Analysis Sample. International Organization for Standardization: Geneva, Switzerland, 2023; p. 5.
51. ISO 1928:2020; Coal and Coke—Determination of Gross Calorific Value. International Organization for Standardization: Geneva, Switzerland, 2020; p. 62.
52. ČSN 07 0240; Warm Water and Low-Pressure Steam Boilers. Basic Regulations. Czech Standards Institute: Praha, Czech Republic, 1993; pp. 1–64.
53. Carroll, J.; Finnan, J. Emissions and Efficiencies from the Combustion of Agricultural Feedstock Pellets Using a Small Scale Tilting Grate Boiler. *Biosyst. Eng.* **2013**, *115*, 50–55. [[CrossRef](#)]
54. Röser, D.; Mola-Yudego, B.; Sikanen, L.; Prinz, R.; Gritten, D.; Emer, B.; Väätäinen, K.; Erkkilä, A. Natural Drying Treatments during Seasonal Storage of Wood for Bioenergy in Different European Locations. *Biomass Bioenergy* **2011**, *35*, 4238–4247. [[CrossRef](#)]

55. Vassilev, S.V.; Baxter, D.; Andersen, L.K.; Vassileva, C.G. An Overview of the Chemical Composition of Biomass. *Fuel* **2010**, *89*, 913–933. [[CrossRef](#)]
56. Vassilev, S.V.; Baxter, D.; Andersen, L.K.; Vassileva, C.G. An Overview of the Composition and Application of Biomass Ash. Part 1. Phase–Mineral and Chemical Composition and Classification. *Fuel* **2013**, *105*, 40–76. [[CrossRef](#)]
57. Lindström, E.; Larsson, S.H.; Boström, D.; Öhman, M. Slagging Characteristics during Combustion of Woody Biomass Pellets Made from a Range of Different Forestry Assortments. *Energy Fuels* **2010**, *24*, 3456–3461. [[CrossRef](#)]
58. Lamberg, H.; Sippula, O.; Tissari, J.; Jokiniemi, J. Effects of Air Staging and Load on Fine-Particle and Gaseous Emissions from a Small-Scale Pellet Boiler. *Energy Fuels* **2011**, *25*, 4952–4960. [[CrossRef](#)]
59. Näzelius, I.L.; Fagerström, J.; Boman, C.; Boström, D.; Öhman, M. Slagging in Fixed-Bed Combustion of Phosphorus-Poor Biomass: Critical Ash-Forming Processes and Compositions. *Energy Fuels* **2015**, *29*, 894–908. [[CrossRef](#)]
60. Nik Norizam, N.N.A.; Yang, X.; Ingham, D.; Szuhánszki, J.; Yang, W.; Rezende, J.; Ma, L.; Pourkashanian, M. An Improved Index to Predict the Slagging Propensity of Woody Biomass on High-Temperature Regions in Utility Boilers. *J. Energy Inst.* **2023**, *109*, 101272. [[CrossRef](#)]
61. Demirbas, A. Combustion Characteristics of Different Biomass Fuels. *Prog. Energy Combust. Sci* **2004**, *30*, 219–230. [[CrossRef](#)]
62. Malaťák, J.; Velebil, J.; Malaťáková, J.; Passian, L.; Bradna, J.; Tamelová, B.; Gendek, A.; Aniszewska, M. Reducing Emissions from Combustion of Grape Residues in Mixtures with Herbaceous Biomass. *Materials* **2022**, *15*, 7288. [[CrossRef](#)] [[PubMed](#)]
63. Weber, K.; Quicker, P. Properties of Biochar. *Fuel* **2018**, *217*, 240–261. [[CrossRef](#)]
64. Basu, P. Combustion of Coal in Circulating Fluidized-Bed Boilers: A Review. *Chem. Eng. Sci.* **1999**, *54*, 5547–5557. [[CrossRef](#)]
65. Johansen, J.M.; Jakobsen, J.G.; Frandsen, F.J.; Glarborg, P. Release of K, Cl, and S during Pyrolysis and Combustion of High-Chlorine Biomass. *Energy Fuels* **2011**, *25*, 4961–4971. [[CrossRef](#)]
66. Ren, X.; Sun, R.; Meng, X.; Vorobiev, N.; Schiemann, M.; Levendis, Y.A. Carbon, Sulfur and Nitrogen Oxide Emissions from Combustion of Pulverized Raw and Torrefied Biomass. *Fuel* **2017**, *188*, 310–323. [[CrossRef](#)]
67. Poudel, J.; Ohm, T.I.; Oh, S.C. A Study on Torrefaction of Food Waste. *Fuel* **2015**, *140*, 275–281. [[CrossRef](#)]
68. Chen, W.H.; Lu, K.M.; Tsai, C.M. An Experimental Analysis on Property and Structure Variations of Agricultural Wastes Undergoing Torrefaction. *Appl. Energy* **2012**, *100*, 318–325. [[CrossRef](#)]
69. Saleh, S.B.; Flensburg, J.P.; Shoulaifar, T.K.; Sárossy, Z.; Hansen, B.B.; Egsgaard, H.; Demartini, N.; Jensen, P.A.; Glarborg, P.; Dam-Johansen, K. Release of Chlorine and Sulfur during Biomass Torrefaction and Pyrolysis. *Energy Fuels* **2014**, *28*, 3738–3746. [[CrossRef](#)]
70. Chen, W.H.; Lin, B.J.; Lin, Y.Y.; Chu, Y.S.; Ubando, A.T.; Show, P.L.; Ong, H.C.; Chang, J.S.; Ho, S.H.; Culaba, A.B.; et al. Progress in Biomass Torrefaction: Principles, Applications and Challenges. *Prog. Energy Combust. Sci.* **2021**, *82*, 100887. [[CrossRef](#)]
71. Tripathi, M.; Sahu, J.N.; Ganesan, P. Effect of Process Parameters on Production of Biochar from Biomass Waste through Pyrolysis: A Review. *Renew. Sustain. Energy Rev.* **2016**, *55*, 467–481. [[CrossRef](#)]
72. Johansen, J.M.; Aho, M.; Paakkinen, K.; Taipale, R.; Egsgaard, H.; Jakobsen, J.G.; Frandsen, F.J.; Glarborg, P. Release of K, Cl, and S during Combustion and Co-Combustion with Wood of High-Chlorine Biomass in Bench and Pilot Scale Fuel Beds. *Proc. Combust. Inst.* **2013**, *34*, 2363–2372. [[CrossRef](#)]
73. ISO 17225-2:2021; Solid Biofuels—Fuel Specifications and Classes—Part 2: Graded Wood Pellets. International Organization for Standardization: Geneva, Switzerland, 2021.
74. ISO 17225-6:2021; Solid Biofuels—Fuel Specifications and Classes—Part 6: Graded Non-Woody Pellets. International Organization for Standardization: Geneva, Switzerland, 2021.
75. Wang, K.; Nakao, S.; Thimmaiah, D.; Hopke, P.K. Emissions from In-Use Residential Wood Pellet Boilers and Potential Emissions Savings Using Thermal Storage. *Sci. Total Environ.* **2019**, *676*, 564–576. [[CrossRef](#)] [[PubMed](#)]
76. Win, K.M.; Persson, T.; Bales, C. Particles and Gaseous Emissions from Realistic Operation of Residential Wood Pellet Heating Systems. *Atmos. Environ.* **2012**, *59*, 320–327. [[CrossRef](#)]
77. Johansson, L.S.; Leckner, B.; Gustavsson, L.; Cooper, D.; Tullin, C.; Potter, A. Emission Characteristics of Modern and Old-Type Residential Boilers Fired with Wood Logs and Wood Pellets. *Atmos. Environ.* **2004**, *38*, 4183–4195. [[CrossRef](#)]
78. Juszcak, M. Concentrations of Carbon Monoxide and Nitrogen Oxides from a 15 KW Heating Boiler Supplied Periodically with a Mixture of Sunflower Husk and Wood Pellets. *Environ. Prot. Eng.* **2014**, *40*, 65–74. [[CrossRef](#)]
79. Ferge, T.; Maguhn, J.; Hafner, K.; Mühlberger, F.; Davidovic, M.; Warnecke, R.; Zimmermann, R. On-Line Analysis of Gas-Phase Composition in the Combustion Chamber and Particle Emission Characteristics during Combustion of Wood and Waste in a Small Batch Reactor. *Environ. Sci. Technol.* **2005**, *39*, 1393–1402. [[CrossRef](#)]
80. Juszcak, M. Comparison of CO and NO_x Concentrations from a 20 KW Boiler for Periodic and Constant Wood Pellet Supply. *Environ. Prot. Eng.* **2016**, *42*, 95–107. [[CrossRef](#)]
81. Johansson, L.S.; Tullin, C.; Leckner, B.; Sjövall, P. Particle Emissions from Biomass Combustion in Small Combustors. *Biomass Bioenergy* **2003**, *25*, 435–446. [[CrossRef](#)]
82. Souček, J.; Jasinskas, A. Assessment of the Use of Potatoes as a Binder in Flax Heating Pellets. *Sustainability* **2020**, *12*, 10481. [[CrossRef](#)]
83. Malaťák, J.; Bradna, J.; Velebil, J. The Dependence of CO_x and NO_x Emission Concentrations on the Excess Air Coefficient during Combustion of Selected Agricultural Briquetted By-Products. *Agron. Res.* **2017**, *15*, 1084–1093.

84. Díaz-Ramírez, M.; Sebastián, F.; Royo, J.; Rezeau, A. Influencing Factors on NOX Emission Level during Grate Conversion of Three Pelletized Energy Crops. *Appl. Energy* **2014**, *115*, 360–373. [[CrossRef](#)]
85. Liu, X.; Luo, Z.; Yu, C. Conversion of Char-N into NOx and N2O during Combustion of Biomass Char. *Fuel* **2019**, *242*, 389–397. [[CrossRef](#)]
86. Ozgen, S.; Cernuschi, S.; Caserini, S. An Overview of Nitrogen Oxides Emissions from Biomass Combustion for Domestic Heat Production. *Renew. Sustain. Energy Rev.* **2021**, *135*, 110113. [[CrossRef](#)]
87. Olave, R.J.; Forbes, E.G.A.; Johnston, C.R.; Relf, J. Particulate and Gaseous Emissions from Different Wood Fuels during Combustion in a Small-Scale Biomass Heating System. *Atmos. Environ.* **2017**, *157*, 49–58. [[CrossRef](#)]
88. Liu, Z.; Balasubramanian, R. A Comparison of Thermal Behaviors of Raw Biomass, Pyrolytic Biochar and Their Blends with Lignite. *Bioresour. Technol.* **2013**, *146*, 371–378. [[CrossRef](#)]

Disclaimer/Publisher’s Note: The statements, opinions and data contained in all publications are solely those of the individual author(s) and contributor(s) and not of MDPI and/or the editor(s). MDPI and/or the editor(s) disclaim responsibility for any injury to people or property resulting from any ideas, methods, instructions or products referred to in the content.