

## Article

# Conventional and Emerging Desalination Technologies: Review and Comparative Study from a Sustainability Perspective

Jamel Orfi <sup>1,\*</sup> , Raed Sherif <sup>2</sup> and Musaad AlFaleh <sup>2</sup>

<sup>1</sup> Mechanical Engineering Department, College of Engineering, King Saud University, Riyadh 11421, Saudi Arabia

<sup>2</sup> Renewable Energy Sector, King Abdullah City for Atomic and Renewable Energy (K.A.CARE), Riyadh 11451, Saudi Arabia; r.sherif@energy.gov.sa (R.S.); m.faleh@energy.gov.sa (M.A.)

\* Correspondence: orfij@ksu.edu.sa

**Abstract:** This work develops a comprehensive review of the main conventional and emerging desalination processes. It presents the state of knowledge of the most known and investigated techniques, highlights their advantages and drawbacks, and draws appropriate conclusions on their respective performances from various angles including their energy consumption and efficiency, environmental impacts, reliability, and flexibility in operations. This review reveals the recent large dominance and deployment of the reverse osmosis technology in the Gulf countries, mainly in Saudi Arabia; the importance of hybridization; and the slow penetration of promising processes including membrane distillation and forward osmosis into the industrial desalination market. In addition, this work aims to develop some comparison exercises between these processes using specific criteria. A cross approach allowing an easier comparison between various desalination processes could help identify the advantages and drawbacks of each technology and select the appropriate process. Therefore, various criteria allowing a clear picture to be drawn of the performance and capabilities of the main conventional and emerging desalination processes have been proposed in the frame of sustainable development. As an illustration of this general approach from sustainability prospects and considering specific weights for each proposed criterion for the case of Saudi Arabia, a comparison exercise reveals that the superiority of reverse osmosis (RO) is confirmed. Multiple effect distillation (MED) and membrane distillation (MD) processes are potentially competitive to RO while multi-stage flash (MSF) comes last due to several drawbacks.

**Keywords:** desalination; sustainable development; metrics; performance indicators; renewable energy; energy efficiency; water cost



Academic Editor: José Luis Sánchez-Lizaso

Received: 18 November 2024

Revised: 9 January 2025

Accepted: 10 January 2025

Published: 20 January 2025

**Citation:** Orfi, J.; Sherif, R.; AlFaleh, M. Conventional and Emerging Desalination Technologies: Review and Comparative Study from a Sustainability Perspective. *Water* **2025**, *17*, 279. <https://doi.org/10.3390/w17020279>

**Copyright:** © 2025 by the authors. Licensee MDPI, Basel, Switzerland. This article is an open access article distributed under the terms and conditions of the Creative Commons Attribution (CC BY) license (<https://creativecommons.org/licenses/by/4.0/>).

## 1. Introduction

As a result of the rapid population growth, increase in industrial activities, pollution, and global warming, water scarcity is projected to be more severe in the future in several regions worldwide. Desalination has been considered a viable solution to provide the needed fresh water despite its high energy requirements and associated environmental impacts.

The growth of the desalination industry, translated by an elevated overall capacity and an increased number of installed and contracted plants, is fast worldwide, especially in Saudi Arabia.

The contracted seawater/brackish water desalination capacity in the Gulf Cooperation Council (GCC) countries is depicted in Figure 1 [1]. In the case of Saudi Arabia, the contracted capacity has shown a notable increase between 2019 and 2022. The Saline Water

Conversion Corporation (SWCC), which recently became the Saudi Water Authority (SWA), has more than 33 operating seawater desalination plants constructed on the Red Sea and Gulf Sea with a total daily capacity of 7.5 million cubic meters. Figure 2 shows that almost half of this total amount is produced in the eastern region with large-capacity desalination plants [2].

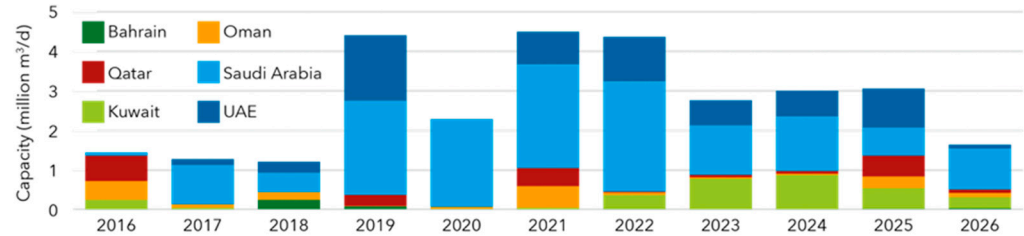

Figure 1. Contracted seawater/brackish water desalination capacity in the GCC countries [1].

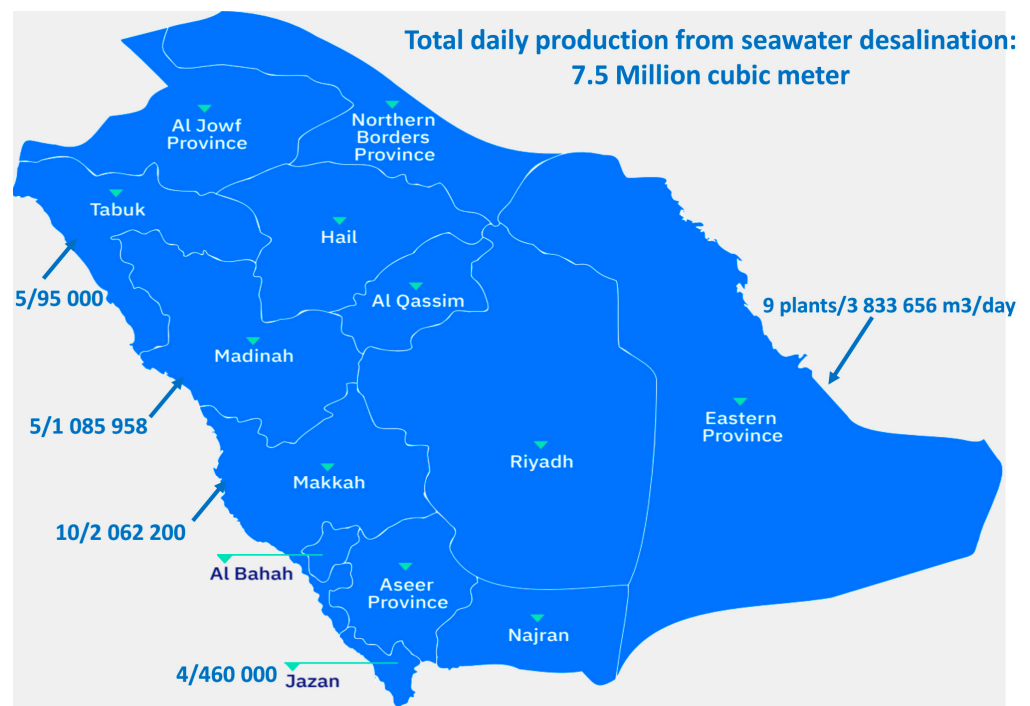

Figure 2. Overall picture of the Saudi seawater desalination plants and capacities (the numbers x/y refer to the number of plants in the region and the corresponding total daily capacity in m<sup>3</sup>, respectively), (adapted from [2]).

There exist various types of desalination processes which can be based on phase change, membranes, or others. There are different ways to classify these desalination processes (Figure 3). They can be organized as:

✓ *Thermal and non-thermal processes:*

Thermal processes refer to evaporation methods including multi-stage flash (MSF), multiple effect distillation (MED), thermal vapor compression (TVC), humidification-dehumidification (HDH), and membrane distillation (MD).

Non-thermal processes incorporate a variety of processes including reverse osmosis (RO), electrodialysis (ED), electrodialysis reversal (EDR), forward osmosis (FO), crystallization (freezing and hydrates) and ion exchange (IX). It is worth mentioning that mechanical vapor compression (MVC) is based on phase change, but it is electrically driven.

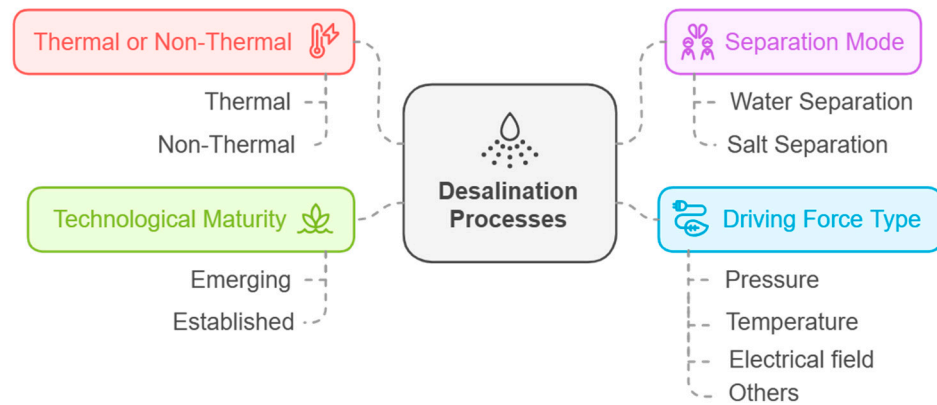

**Figure 3.** Ways of classifying desalination processes.

- ✓ *Separation mode of water or salts*
- Water separation concerns processes by which water is removed from the feed solution. This includes evaporation, crystallization, and membranes.
- Salt separation is the process by which salts are removed from the feed solution including EDR, ED, and ion exchange.
- ✓ *Conventional (mature and deployed at large scale) or non-conventional (lab scale or still in research and development stage).*

MSF, MED, RO, and ED are considered mature technologies. MD, HDH, and FO are non-conventional methods.

- ✓ Another interesting way to classify the desalination processes is by referring to the *type of driving force*. One can have four classes, namely thermal, mechanical, electrical, and chemical. Desalination plants can also be classified based on their capacity as highlighted in Table 1.

**Table 1.** Desalination plant capacity ranges (in m<sup>3</sup>/day) as reported by [3].

Small	Medium	Large	x-Large	Mega
<1000	1000–9999	10,000–49,999	50,000–250,000	>250,000

The number of bibliometric analyses on the state-of-the-art hotspots and outlooks on conventional and new desalination processes has sharply increased over the last few years [4–14]. Emerging desalination processes such as membrane distillation (MD), forward osmosis (FO), and capacitive deionization (CDI) have been attracting real and increasing interest during the last few years among the R&D community [6,8,10,11,13]. Integration of renewable energy sources to drive desalination systems, brine discharge and management, and mineral recovery are also important subjects with high interest [9,14]. Eke et al. [15] compiled and analyzed desalinated data from over six decades to draw possible future trends and conclusions. They highlighted the sharp increase in desalination capacities and the large share of the capital cost of the specific cost of desalinated water. Recently, Politano et al. [16] presented a roadmap on membrane desalination technology within the frame of the water–energy nexus acknowledging the main challenges and opportunities and the importance of process optimization and innovative material development. Important issues such energy consumption, membrane degradation, and brine discharge were discussed. Politano et al. [16] developed promising ideas on the concept of circular economy particularly with respect to brine valorization in terms of the recovery of valuable minerals and metals and the production of blue energy (salinity gradient power) as renewable energy.

The breakthrough and development of emerging desalination processes have been addressed by Ahmed et al. [17] who discussed the status, challenges, and trends of emerging technologies and focused in particular on forward osmosis, membrane distillation and electrochemical desalination techniques. Ahmed et al. [17] observed that the number of pilot-scale studies is very few, and more efforts are required to increase the technological development and readiness of these processes.

Ihsanullah et al. [18] pointed out that despite the enormous benefits of desalination, including social, health, and economic ones, its environmental impacts (EIs) can result in major concerns. The authors discussed mitigative measures to reduce these environmental impacts and develop effective brine disposal and management methods.

Elsaid et al. [19] presented a clear picture on the various EIs of the main desalination technologies from the source (intake) to the discharge (outfall). The development of new processes and the improvement of existing ones, joined with the implementation of efficient design selection and process optimization, can help reduce these EIs.

In their comparative study of desalination technologies, Youssef et al. [20] compiled the main findings of previous results based on the following:

- The desalination technologies' capabilities to treat concentrated waters and produce high quality water.
- The amount of thermal and electrical energy consumed (STEC and SEEC).
- The amount of released CO<sub>2</sub> in kg/m<sup>3</sup> of produced water.
- The following Table 2 summarizes their compilations.

**Table 2.** Energy consumption, CO<sub>2</sub> emission, and water cost information of main desalination technologies (adapted from compiled results in Youssef et al. [20]).

Process/Criterion	MSF	MED	MVC	RO	FO	ED	HDH
STEC (kWh <sub>th</sub> /m <sup>3</sup> )	19.4	16.4	0	0	0	0	120
SEEC (kWh <sub>el</sub> /m <sup>3</sup> )	5.2	3.8	11.1	8.2	5	5.5	3
CO <sub>2</sub> release (kg of CO <sub>2</sub> /m <sup>3</sup> )	6.9	5.5	5.1	3.8	2.3	2.5	29.1
Water cost (USD/m <sup>3</sup> )	0.96	0.86	0.92	0.75	0.8	0.83	3.93

The results presented in Table 2, as compiled by Youssef et al. [20], did not take into consideration the effects of important indicators such as the plant size and the feed water salinity.

The comparative study of desalination technologies conducted by Chebli et al. [21] was based on three important aspects, namely environmental, technical, and economic ones. Each can be measured using specific indicators which are the gas emission rate, the thermal and electrical energy consumption, and the total unit cost of water. The compiled results showed that RO has the lowest CO<sub>2</sub> emissions and total energy consumption. The authors highlighted that using renewable energy sources in desalination increases the water cost as compared to the case with fossil fuels. For instance, the unit water cost produced using MED technology driven by concentrated solar power (CSP) ranges between 2.4 and 2.8 USD/m<sup>3</sup>. This picture is changing, however, since the solar collectors' prices are decreasing.

Naseer et al. [14] proposed a bibliometric study to map the history of desalination research and unearth important and hot research topics. They employed the analytical hierarchy process (AHP) to identify the desalination technique that was the most energy efficient and with the lowest water cost. The consolidated results of the AHP revealed that energy consumption is the highest priority parameter, followed by the unit water cost and

the CO<sub>2</sub> emissions. The authors considered the following parameters in the AHP analysis: energy demand, CO<sub>2</sub> emission, product water salinity, product water cost, feed salinity, plant capacity, and operational temperature. Based on their analysis, RO ranks first as the best available desalination technology followed by MSF and MED.

In another case, the bibliometric study of Naseer et al. [14] revealed that membrane fouling, energy consumption, pre-treatment, water reuse, and scaling are the main challenges in membrane-based desalination techniques.

Altmann et al. [22] proposed to compare desalination technologies by evaluating their primary energy consumption. Based on comparing about 50 different configurations of electricity and water production, the study elucidated that the co-generation of electricity and water technologies can be fairly compared from a common primary energy source. The results showed that although RO is the lesser energy-intensive process, the energy consumption gap between RO and thermal desalination technologies is reduced.

Thi et al. [23] presented a comprehensive comparison of desalination technologies employing various approaches including life cycle analysis and multi-criteria decision analysis. The authors discussed the impacts of MSF, MED, and RO on the ecosystem, resources, and human health.

Therefore, the authors explained the importance of the political and legal aspects as well as the social, economic, environmental, and technical ones. They discussed in detail the impact of desalination on human health damage. It was found that the use of renewable and nuclear energy as energy sources significantly reduces the impact on human health. The compiled results clearly show that the renewable energy desalination is costly compared to fossil-fueled desalination, thus recommending further focus on advancing technology development of low-cost, clean energy systems and efficient integration with desalination.

The various studies comparing desalination technologies put forward the difficulty in achieving unified and tangible conclusions allowing a systematic and direct comparison and selection of those techniques. This is attributed to various factors including the numerous parameters affecting these water–salt separation technologies and their complex interconnection. Furthermore, the importance and weight of each of these influential parameters are not known and have not been determined accurately.

Therefore, despite the high number of published works on desalination technologies, the available results concern compiling important and useful information on specific aspects associated with desalination such as energy consumption, membrane development, and environmental impacts. Sustainability and its requirements have become pervasive in various technologies. Therefore, with the new and urgent constraints of sustainability in energy and water technologies including desalination, it becomes imperative to develop adequate approaches helping to assess the alignment of these technologies and processes within the sustainability frame. Comparing various desalination processes from sustainability perspectives becomes a primordial target and a challenging task. Therefore, a cross approach allowing an easier comparison between various desalination processes could help identify the advantages and drawbacks of each technology. Considering the requirements of sustainability, proposing appropriate metrics allowing accurate comparison of the desalination techniques is a central objective. Meanwhile, Saudi Arabia, which is the largest desalinated water producer worldwide, has established impressive strategies directed towards relying more and more on clean and sustainable energy sources in various technologies, principally in power generation and desalination. The aim of this work is also to assess the available and future desalination technologies in Saudi Arabia.

This work is organized as follows. A description is first presented of the main desalination processes that can be conventional or emerging ones. Section 2 focuses on hybrid

desalination, while the last section is dedicated to developing a step-by-step approach aiming to appropriately compare various desalination technologies.

## 2. Description of the Main Desalination Processes

### 2.1. Thermal Desalination Technologies

Traditionally, conventional distillation techniques have been widely used, in particular, in oil-producing countries where the fuel cost was very low. They showed a high level of reliability and ensured performance under varied conditions [24]. MSF technologies, for example, have shown themselves to be robust and reliable for achieving specific freshwater quality requirements given the high salinity of Gulf seawater and its biological activity [25]. The situation has been reversed in the last two decades. RO technology has largely dominated the desalination industry in this last period. More than 65% of the overall worldwide desalination capacity is through RO technology [26]. RO has achieved high technological development in various areas including the development of new advanced membranes and their compact assembly in spiral-wound configurations [4]. Additionally, RO electrical energy consumption has shown an impressive reduction to reach about 3 kWh/m<sup>3</sup> of fresh water produced. The situation in Saudi Arabia has shown a similar trend to the global picture. For instance, the last decade has shown a sharp diminution of thermal desalination in the Saudi market share, especially of MSF technology, as translated by the fact that almost all constructed plants in the last 10 years are based on the RO process [2]. In fact, SWCC has recently implemented a strategic initiative that consists of decreasing the reliance on thermal desalination processes, namely MSF and MED, in favor of RO technology. Therefore, it is expected that the proportion of RO desalination plants will reach 83% in 2026 [2].

It is worth noting that some recent studies on thermal desalination have been turned to developing systematic experimental investigations on evaporation and condensation enhancements for interfacial solar evaporation-based systems (ISES). The key components around which solar interfacial evaporation is centered and based include a solar absorber and converter to heat, floating evaporation mechanism for liquid supply to the heated region, and a thermal insulation device [27,28]. Innovative concepts based, for example, on better supplied heat management via heat localization and redistribution and use of appropriate materials as effective solar absorbers can boost the development of the ISES. However, these systems are still based on passive mechanisms which delay their industrial scale development.

The basic principles of the main thermal desalination processes are given below.

#### 2.1.1. Multiple Effect Distillation

The basic idea of MED is to make use of the steam generated in one evaporator to act as the heating medium in a second evaporator, and so on. The second evaporator must be at a lower pressure than the first. There are essentially four MED configurations based on the feed arrangements. Those widely used in the desalination industry are the parallel cross, parallel feed, and forward feed configurations. Figure 4 presents a schematic diagram of a five-effect MED unit with a parallel feed configuration. The latter is employed among others in the MED industry.

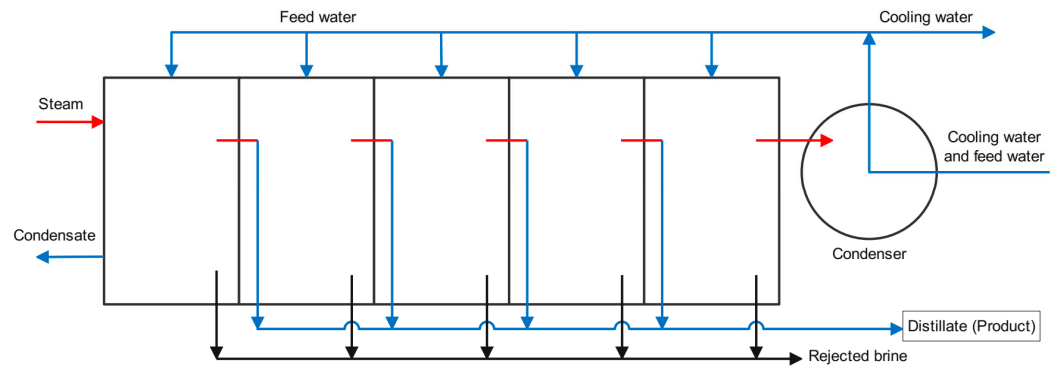
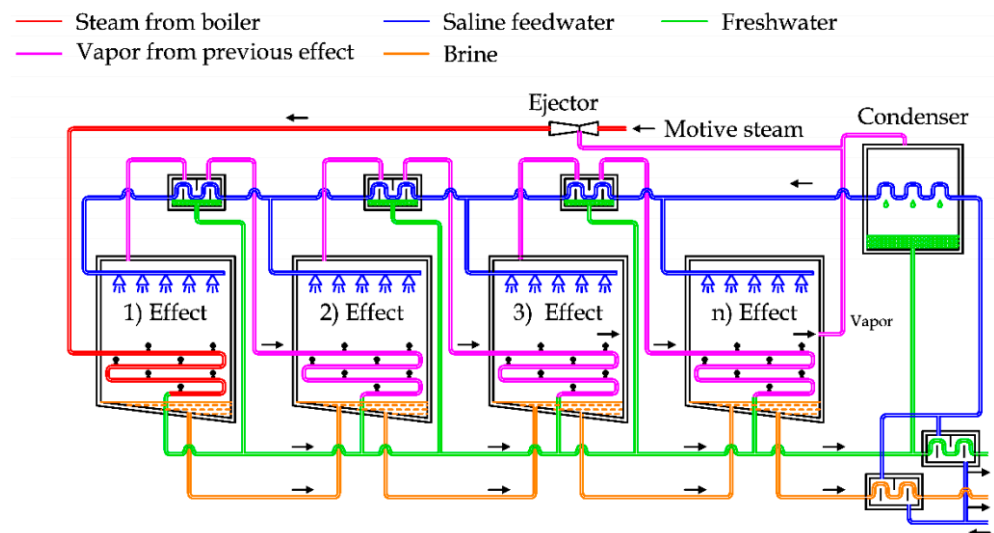

**Figure 4.** Schematic diagram of a parallel feed configuration MED unit with 5 effects.

The MED basic structure can be enhanced by various means. Preheaters have been added between successive effects. The incorporation of thermal vapor compression (TVC) into the MED has received much attention in research. It has a high impact on reducing the overall specific energy consumption and reducing the total cost of desalinated water for a fixed desalination capacity. Such modifications to the basic MED structure, particularly adding the TVC, allowed a significant increase in the unit capacity as shown in Table 3. The maximum capacity of a MED-TVC unit reached in 2018 was 20 MIGD, or 90,920 m<sup>3</sup>/day. The number of effects can range between 5 and 20 effects in large MED plants [29]. Figure 5 shows schematically a parallel cross-MED unit with preheaters and a TVC system [9].

**Table 3.** MED unit capacity evolution between 1990 and 2018 [30–32] (1 MIDG = 4546 m<sup>3</sup>/day).

Unit Capacity (MIGD)	1	5	10	15	20
Year	1990	2000	2009	2012	2018



**Figure 5.** Schematic diagram of a parallel cross MED with preheaters and a TVC system [9].

Additionally, MED is designed in such a way that its top brine temperature (TBT) ranges between 60 and 85 °C. Operating at higher TBT values would increase freshwater production since more effects could be considered in the unit. However, this is not preferable since it results in a higher potential for corrosion and scaling on the external surfaces of the evaporator tubes and other unit components [30].

The MED process is known to be more energy efficient than MSF, thus requiring less energy for the same product capacity and quality [9,25]. Another important feature of MED

is related to its ability to be driven by low-grade heat (low source temperature) and the fact that it can be smoothly integrated with renewable energy sources including solar thermal.

### 2.1.2. Multi-Stage-Flash

Multi-stage flash desalination technology has been widely employed in the Kingdom of Saudi Arabia and other oil-producing countries as a reliable technology to ensure high freshwater production capacity. It exists under two major configurations: once-through (MSF-OT), and brine recirculation (MSF-BR). Figure 6 gives a schematic of a once-through MSF plant.

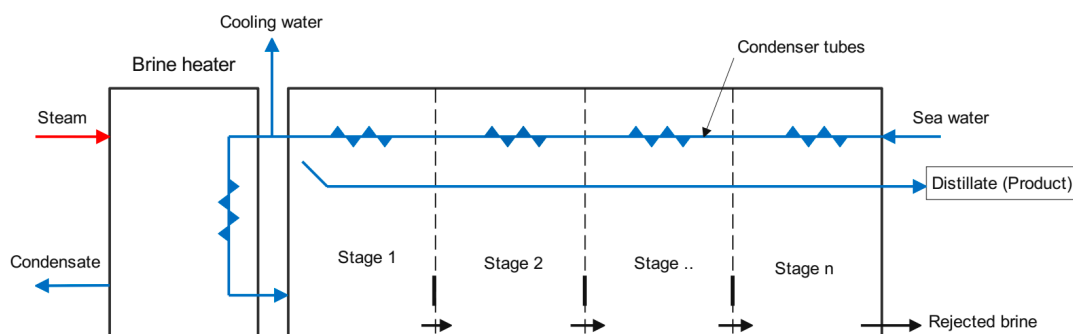

**Figure 6.** A schematic diagram of a once-through MSF plant.

The seawater stream passes through heat exchangers where it recovers the heat of condensation of the formed vapor by flashing in the lower part of the MSF chamber, which results in increasing its temperature. The preheated feed water is then heated in the brine heater to its predefined maximum temperature, known as the top brine temperature (TBT). It enters the first vacuum chamber where sudden phase change or flashing occurs. By flashing, the formed water vapor goes up through a demister and then condenses after its direct contact with the external surfaces of the condenser tubes in which the feed water circulates. The non-evaporated brine moves to the second chamber and similar steps take place. The process is repeated in the subsequent stages. The overall efficiency of this distillation process depends on various parameters including the top brine temperature, the cooling water temperature, and the feed salinity. The configuration illustrated in Figure 6 concerns the once-through MSF configuration. There are other, more complex configurations where concentrated brine is recirculated. They are characterized by their large capacity, reliability, and smooth integration with power plants in cogeneration modes [31,33,34]. Figure 7 depicts the principle of an MSF plant with brine recirculation (MSF-BR). A heat rejection section composed of two or three flash stages is inserted. In MSF-BR structures, the number of stages can reach 40 stages [35].

Even though MSF technology is the most energy-intensive among the conventional desalination processes, it can be used in large cogeneration power plants where cheap energy sources are available. Furthermore, thermal renewable energy sources such as solar and geothermal energy can be explored and integrated with MSF-OT structures. The readers can consult for further details [36–38]. Ali et al. [39] proposed and assessed advanced hybrid MSF-based desalination configurations that can be driven by low-grade energy such as geothermal and waste heat. Ali et al. [34] proposed a novel MSF configuration that consists of reversing the brine circulation path as compared to conventional MSF structures. In addition, process enhancement through conducting rigorous optimization studies can contribute to substantial improvements of the MSF plants' performance [40].



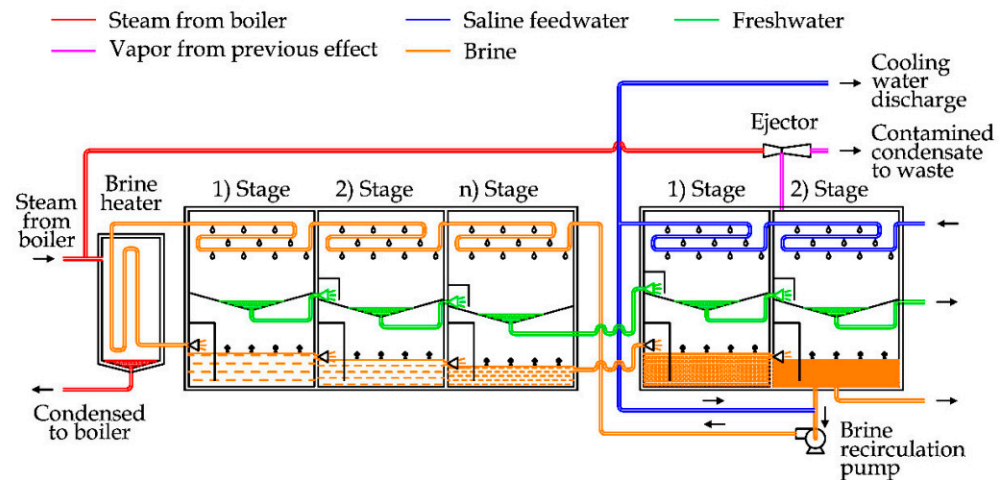

Figure 7. A schematic diagram of an MSF structure with brine recirculation [9].

2.1.3. Vapor Compression (VC)

When a gas is compressed, its temperature increases too. Therefore, the basic idea of VC is to heat the vapor by compressing it using a mechanical vapor compressor (MVC) or a thermal vapor compressor (TVC). An ejector is commonly used as TVC. The VC process can be described schematically using Figure 8. The feed water (seawater or brackish water) after a preheating step is converted to vapor and compressed mechanically by MVC or thermally using an ejector. The compressed vapor with a higher temperature circulates inside the heat exchanger tubes and condenses because of the heat transfer with the colder sprayed feed water.

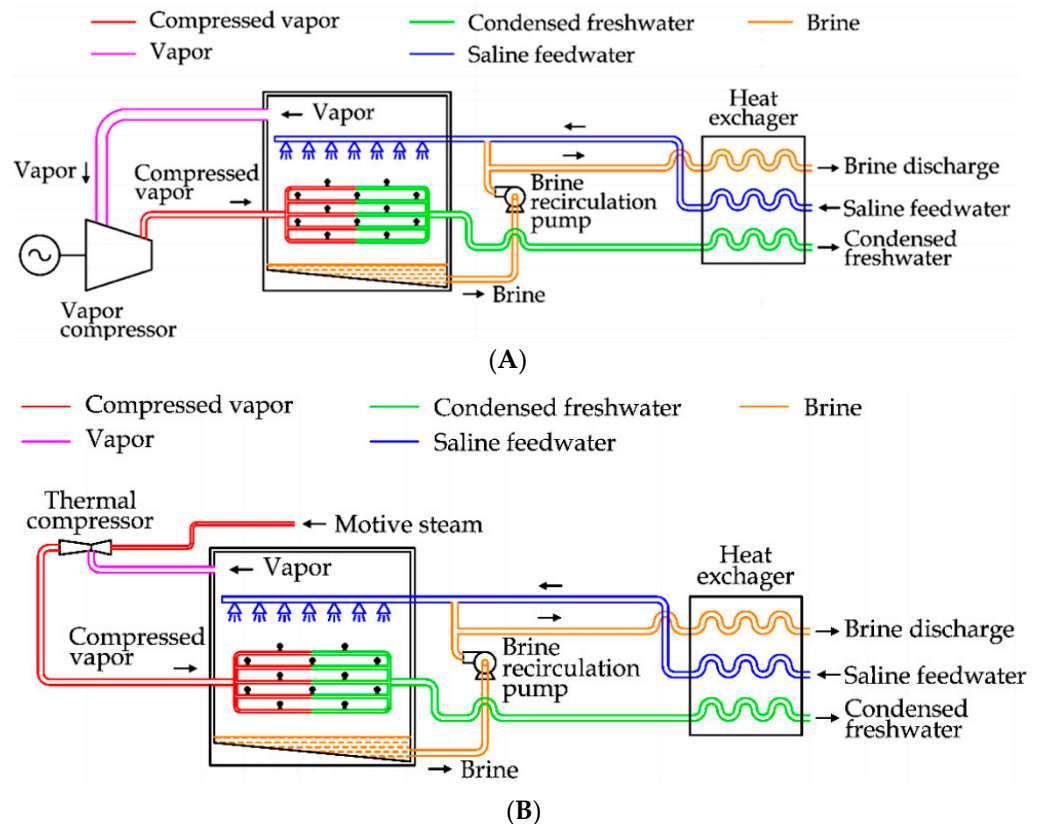

Figure 8. Schematic diagrams of (A) mechanical vapor compression and (B) thermo-vapor compression desalination [9].

Vapor compression systems can be used for desalination alone but are more effective when integrated with other desalination processes, mainly the MED process. MED-TVC integration has been proven to be effective and viable from energy efficiency and economic points of view [26,41]. Recently, multiple attempts have been made to develop advanced systems integrating mechanical vapor compression (MVC). MVC and related systems are independent of steam generation sources [42]. They are known to be robust and reliable and can treat highly concentrated waters [43], which recommends their potential applications in zero liquid discharge (ZLD) strategies. MVC-based desalination systems have been known to suffer from low water production capacity due particularly to the low capacity of available compressors [44]. They are frequently considered as an option for low- to medium-scale (100–5000 m<sup>3</sup>/day) concentrated water desalination [45]. Recent developments in evaporator and compressor designs present MVC systems as competitive alternatives in the desalination industry [42,43].

## 2.2. Membrane Desalination Processes

### 2.2.1. Reverse Osmosis Process

Reverse osmosis (RO) has dominated the desalination industry worldwide in the last two decades. In 2016, RO technology represented about 65% of the global installed capacity, while MSF came second with about 20% and MED with 7% [46]. This picture has slightly changed in favor of RO. In 2022, the contribution of RO to the global market was about 69% while the contribution of MSF slightly declined to 18% and MED kept constant at 7% [47]. RO is a pressure-driven, membrane-based desalination in which the pore size varies between 10<sup>-4</sup>–10<sup>-3</sup> μm (Figure 9) [48]. Its purpose is to remove from the feed saline solution all colloidal matter and dissolved solids.

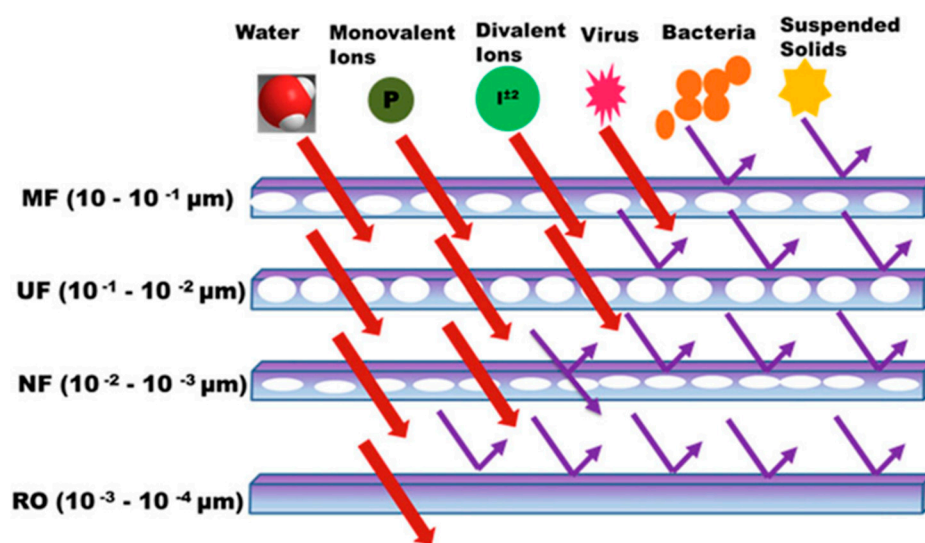
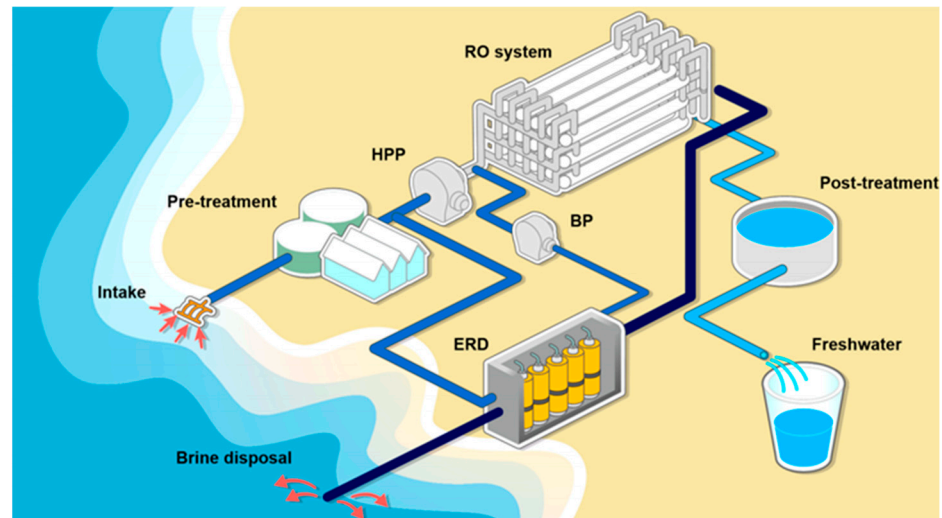

Figure 9. Reverse osmosis as a filtration system [48].

The principle of the RO process is based on applying pressure higher than the osmotic pressure to force a reverse flow of water from a high salt concentration (saline solution) to a lower one (fresh water). The applied pressure is typically double the osmotic pressure. Therefore, it rises with salinity. High-pressure pumps operating at 15–27 bar for brackish water desalination (BWRO) and 50–80 bar for seawater desalination (SWRO) are used [48]. This is to highlight that desalinating concentrated water using RO is highly electric energy-intensive in addition to associated problems such as fouling and scaling that may result in operational limitations and shortening of the membrane life.

A typical SWRO is presented in Figure 10 [49], showing its main components such as the intake and outfall structures and the prefiltration and posttreatment systems as well as

various hydraulic devices such as the high-pressure pumps (HPP), the booster pump (BP), and the energy recovery device (ERD).



**Figure 10.** Illustration of a typical SWRO desalination plant showing its main components (BP: Booster pump; HPP: high-pressure pump; ERD: Energy recovery device) [49].

The use of ERD in a SWRO plant has become almost mandatory in the desalination industry since it recovers the mechanical energy of the rejected brine and converts it into electrical power, reducing the overall electricity consumption of the entire plant. ERD, which is almost exclusively a pressure exchanger that transfers the brine pressure to the feed stream with an efficiency ranging between 95% and 97%, can contribute to reducing the RO-specific energy consumption by about 60% as compared to the case without a recovery system [50]. Figure 11 illustrates the seawater, brine, and permeate streams in a typical spiral-wound RO configuration. Permeate water crosses the pores of the semi-permeable membrane while impurities cannot.

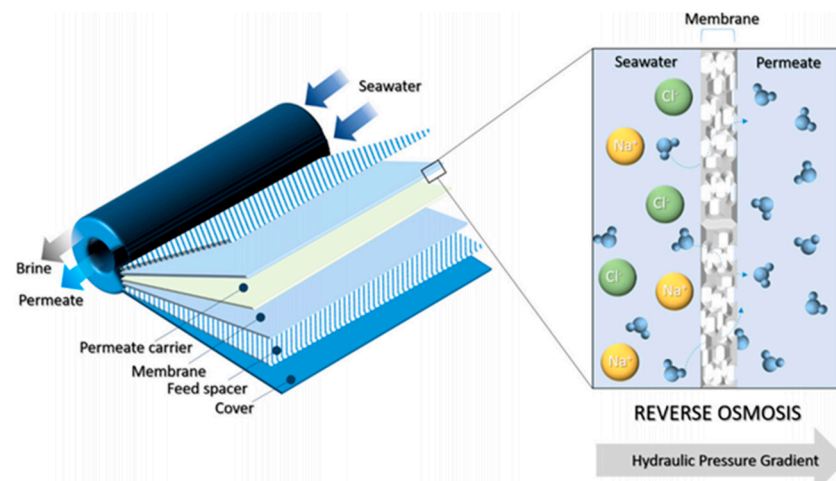

**Figure 11.** Permeate water crossing the pores of a semi-permeable membrane in a spiral-wound configuration [50].

The RO process is known to be modular, which is a central advantage over the other conventional desalination processes. Therefore, upscaling of an RO plant's capacity is not a limitation. Large-scale operating RO units can have a capacity of 500,000 m<sup>3</sup>/day (Magtaa plant, Algeria) [51]. A larger RO desalination capacity of 600,000 m<sup>3</sup>/day was reported in 2022 [52]. An RO desalination plant is composed of one or more trains. To the knowledge of the authors, the maximum train capacity is 8 MIGD (36,368 m<sup>3</sup>/day) [53].

The power consumption repartition across the different steps of a SWRO plant is estimated to be 68% for an RO system, 15% for the intake structure and devices, 8% for the pre-filtration, and 7% for the distribution, while just 1% for the permeate treatment [54].

The membrane behavior in harsh feed waters and critical operating conditions and the energy consumption of RO plants remain major frames to increase the overall performance and reduce the total cost of produced water. Alnajdi et al. [55] collected comprehensive data from more than 60 RO facilities and conducted analyses on various aspects including membrane permeability, energy efficiency, and mass transfer. They highlighted particularly the importance of improving the membrane spacers and adopting RO batch structures with higher efficiency. RO, which has emerged in the last decades as the standard water desalination technology, still has challenges to address. These include the mitigation of fouling and mineral scaling as well as the reduction in total cost (Cohen et al. [56]). Improvements in the RO process can include developing advanced configurations with multi-staging and concentrate recirculation, and more efficient membrane element design. To increase the membrane lifetime and reduce the plant footprint, Cohen et al. [56] recommended developing membranes with higher permeability, low fouling potential, and high resistance to disinfectants. Similarly, batch RO systems have gained real interest as innovative RO configurations with potentially minimized specific energy consumption (SEC) at high recovery, as reported by Davies et al. [57,58]. Werber et al. [59] developed analytical and numerical models to evaluate the energetics of time variant RO processes (batch and semi-batch). Promising configurations with notable energy savings have been proposed.

Therefore, and despite the numerous RO advantages over other conventional desalination technologies including its equipment compactness, lower electric energy consumption, and lower operating costs, it suffers from several limitations, some of which are critical:

- Membrane fouling.
- Lower recovery ratio, mainly for seawater, which results in dumping large amounts of concentrated brine back to the natural body.
- The use of high-grade energy (electric power), even at low rates.

### 2.2.2. Electrodialysis (ED)

ED is a voltage-driven membrane process that removes salt ions from the feed solution compartment. The feed water is purified by using suitable membranes located at the positively and negatively charged electrodes. ED is essentially used for brackish water desalination and is limited to a salt concentration level of less than 10,000 ppm [24]. Its deployment on an industrial scale is limited as compared to RO. Figure 12 illustrates the principle of ED [60].

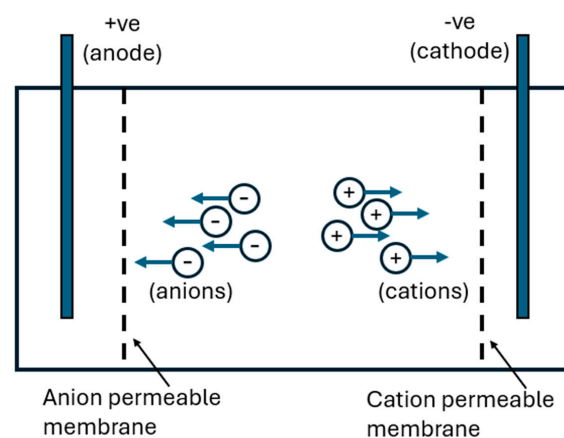
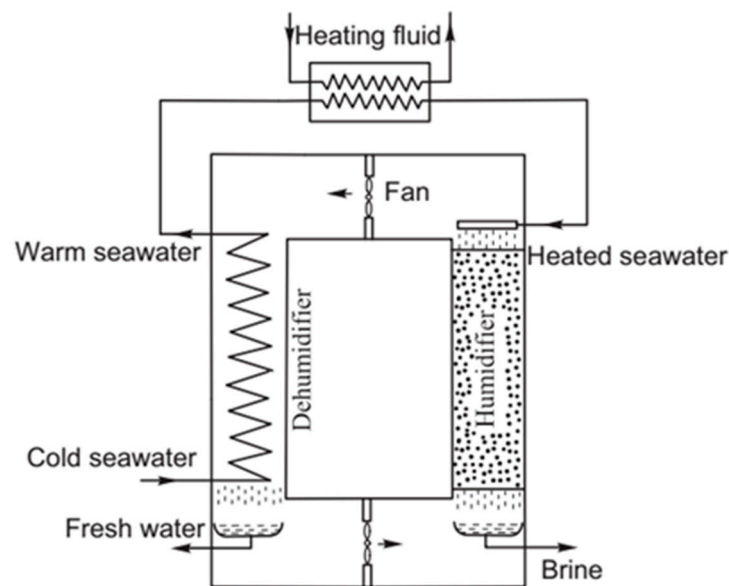

**Figure 12.** A simplified diagram illustrating the principle of the electro dialysis desalination process (adapted from [60]).

### 2.3. Other Desalination Methods

#### 2.3.1. Humidification-Dehumidification (HDH)

The humidification–dehumidification (HDH) process is based on the idea that fresh water can be collected by condensing the air humidity. It consists of inducing water evaporation at atmospheric pressure into the air as a gas carrier and then condensing the formed vapor. The humidifier, a kind of wet cooling tower, and the dehumidifier are core components of the HDH process (Figure 13) [61]. Despite a real interest from the research community in the last two decades, which has been translated by a good number of publications, the process has limited penetration at the industry level. This is associated with its limited performance compared to conventional thermal desalination technologies such as MED and MSF.



**Figure 13.** A schematic of the humidification-dehumidification (HDH) process [61].

Major HDH features can be summarized as follows:

- Simple design, robust under high salt concentration, membrane-free.
- It can be integrated with solar thermal and geothermal energy.
- Air flow required is very high for few produced distillate rates.
- The required energy consumption is high.
- Upscaling is very difficult. Therefore, it can be intended for small-scale units.

#### 2.3.2. Freezing Desalination (FD)

The FD process consists of freezing water and removing it from saline solution as ice crystals. The major advantage of FD is, a priori, the low energy required for separating water and salts. The energy needed is around one seventh of the evaporation latent heat of the distillation processes. Operating at low temperatures results in fewer scaling and corrosion problems and enables the use of low-cost materials such as plastics. However, the process is still far from commercial implementation despite the efforts and attention of the last decades. The main drawbacks of FD are its high operating and capital cost during the ice separation and washing steps, low rejection rates, and the various complex operations related to the freezing process. The FD process has two main stages: ice crystallization, and separation and melting. Figure 14 illustrates the main FD steps and main components. Further details on FD can be found in [62,63].

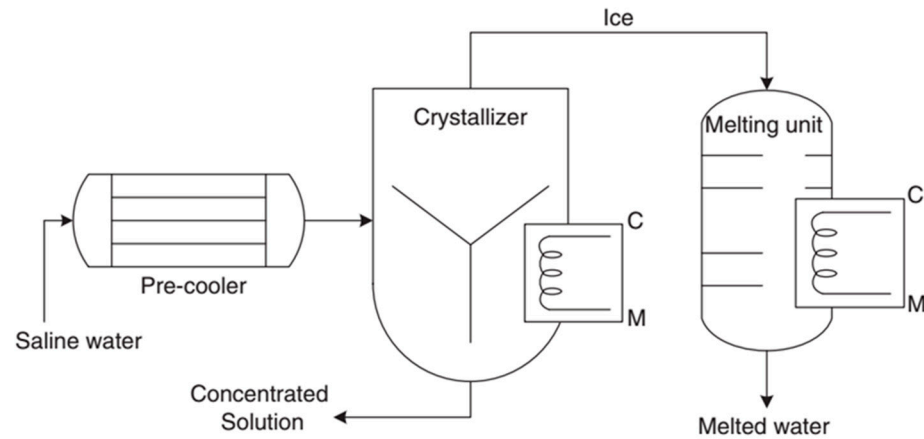

**Figure 14.** Main components of freezing desalination (FD): pre-cooler, crystallizer, and melting unit [62].

### 2.3.3. Capacitive Deionization (CDI)

Capacitive deionization (CDI) is based on ion electro-sorption and consists of removing dissolved, charged ionic species from aqueous solutions. It removes ions from the saline solution at atmospheric pressure using direct current electric power (Figure 15). It is also used for water softening and wastewater remediation [64]. It is considered a promising desalination process mainly for low salinity feed waters such as brackish waters. Additionally, the process operates at low voltage levels making it a less energy-intensive and a low-cost technique [65]. Further advanced studies on all CDI aspects including process intensification and material properties are required. Exhibiting high electrical conductivity, a good wettability to water, and chemical stability are important criteria of the electrode material properties for CDI development and larger deployment [66,67]. Ahmed and Tewari [66] reviewed the main studies up to 2017 on CDI and focused on the process and internal mechanisms, materials used, and state of the technology. Improving electrode characteristics and process optimization were identified as major parameters for future directions and development prospects. Wang et al. [67] have identified the poor cycling stability of CDI as a critical issue limiting the technological progress of the process. They analyzed several inherent side reactions occurring during long-term operation and proposed various ideas to boost the separation process stability. For further readings on various vital aspects of CDI, references [68–70] are recommended.

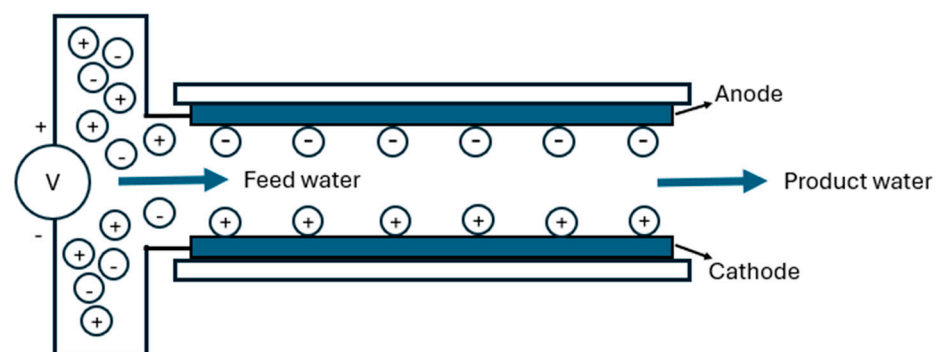
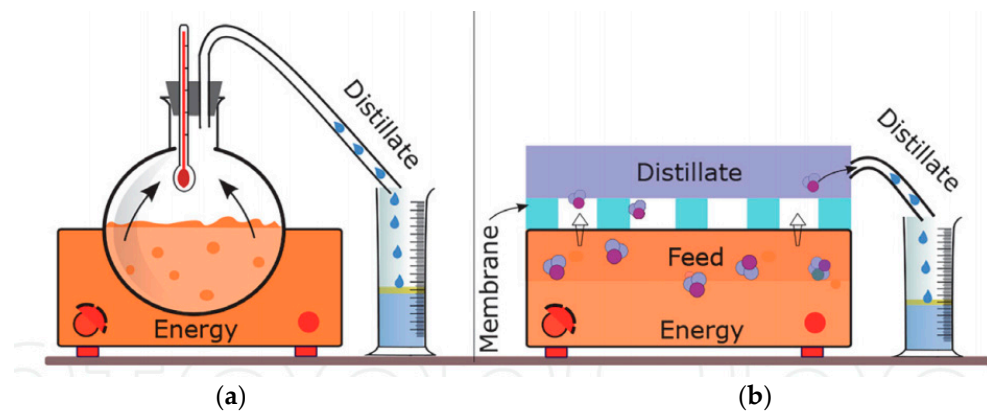

**Figure 15.** Schematic diagram of a capacitive deionization (CDI) process (adapted from [64]).

### 2.3.4. Membrane Distillation (MD)

Membrane distillation (MD) is essentially based on an elementary distillation system but with the use of a membrane (Figure 16) [71]. MD can be considered a hybrid thermal-membrane desalination process that produces pure water from a hot saline solution using a hydrophobic membrane. The separation process is driven by a vapor pressure differential

between the feed saline solution and the permeate side, which causes the feed stream to evaporate on the hot side of the membrane, and then the generated vapor moves across the hydrophobic membrane to the permeate side.



**Figure 16.** (a) Basic distillation system and (b) Membrane distillation system [71].

MD is a promising desalination method known for its attractive attributes. For example, MD can run under atmospheric pressure and modest temperature (40~80 °C), scores about 100% salt rejection factor, and can be driven by low-grade energy sources [71,72]. Moreover, it can treat highly concentrated water solutions [73]. Therefore, MD technology smoothly penetrates the desalination market via specific applications that include brine concentration and crystallization, solar-powered small-scale units for remote and rural regions, and integrating with conventional processes such as MED or RO [16,71].

As compared to the RO process and despite its low energetic efficiency translated by its high energy consumption rates, MD has the advantage of being driven by low-grade energy and low temperature and pressure levels. Additionally, MD can treat high saline waters without being limited by the osmotic phenomenon or by the concentration polarization. On the other hand, MD is known for its substantial specific thermal energy consumption [25]. Previous studies on MD design and operation have shown that energy recovery devices can be smoothly implemented internally or externally into the MD core module, contributing to considerably enhancing the overall energy efficiency of the process [16,73]. Therefore, contributing to developing ways to reduce the energy consumption of MD is a pivotal objective. Possible ways to improve the membrane distillation process are summarized in Figure 17. These ways are related to several aspects including energy consumption and management, development of new types of membranes, and hybridization with other desalination processes.

MD can be operated under various configurations. The widely used and basic ones are direct contact membrane distillation (DCMD), air gap membrane distillation (AGMD), sweeping gas membrane distillation (SGMD), and vacuum membrane distillation (VMD) [74]. Figure 18 shows schematically the difference between these basic configurations. Several derived MD configurations from those basic ones have been proposed and tested. Schwantes et al. [75] experimentally evaluated the performance of a novel plate and frame MD called Feed Gap Air Gap MD (FGAGMD), intended to be used for concentrated brines. Results on energy efficiency show similar trends to those of a spiral-wound air gap membrane distillation (AGMD) module while a sharp increase in the recovery ratio was obtained.

## Enhancing Membrane Distillation Processes

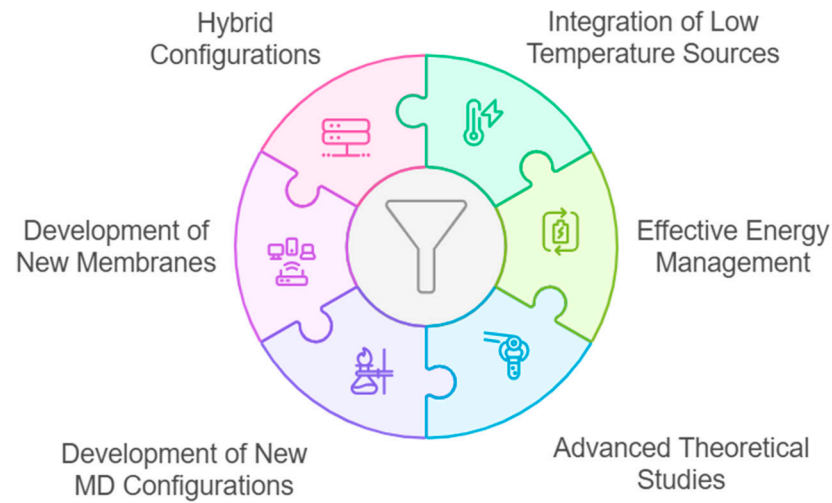

**Figure 17.** Main ways to improve the performance of membrane distillation systems.

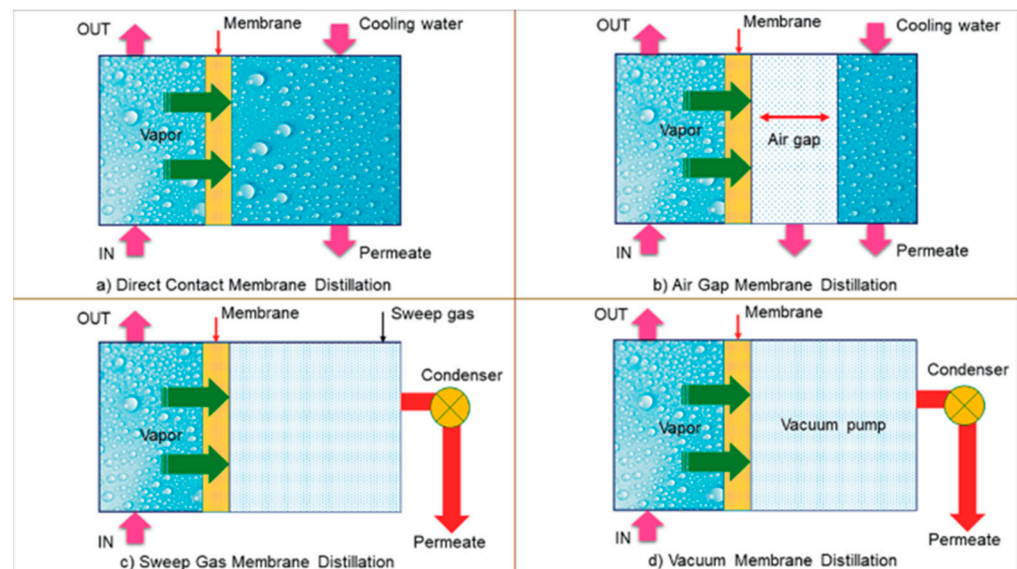

**Figure 18.** Basic MD configurations: (a) Direct contact membrane distillation (DCMD), (b) Air gap membrane distillation (AGMD), (c) sweeping gas membrane distillation (SGMD), and (d) Vacuum membrane distillation (VMD) [74].

MD modules can be used under various arrangements including tubular, plate and frame, hollow fiber, and spiral-wound. Figure 19 illustrates the plate-frame and spiral-wound modules [74]. An interesting illustration on the performance of some pilot scale MD variants expressed in terms of gain output ratio and trans-membrane permeate flux is depicted in Figure 20 [16]. Figure 20 refers to extensive experimental tests at the pilot scale of a hybrid AGMD and VMD called vacuum-enhanced air gap MD. Two commercial spiral-wound modules with membrane areas of 7.2 and 25.9 m<sup>2</sup> were used. The obtained results show the benefits of using vacuum in the AGMD as compared with the original versions of VMD or AGMD. The conducted tests which cover a wide range of feed salinities resulted in encouraging and promising findings on the performance of this vacuumed air gap membrane distillation configuration. The data reported that the specific thermal energy consumption of this enhanced MD system is about 50 kWh/m<sup>3</sup>, which is considered low as compared to other MD basic configurations.



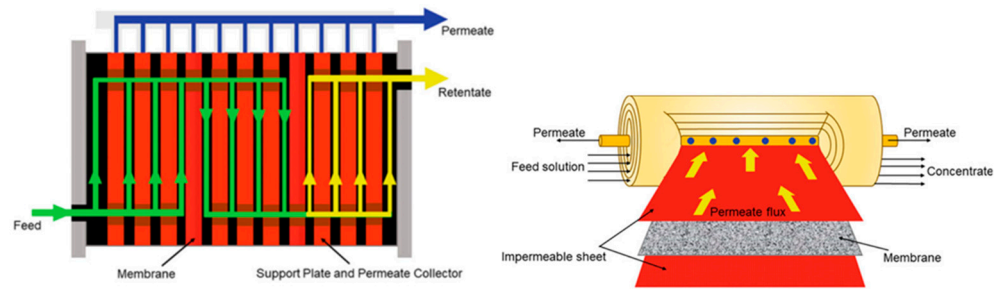

Figure 19. MD modules: left—plate-frame, and right—spiral-wound [74].

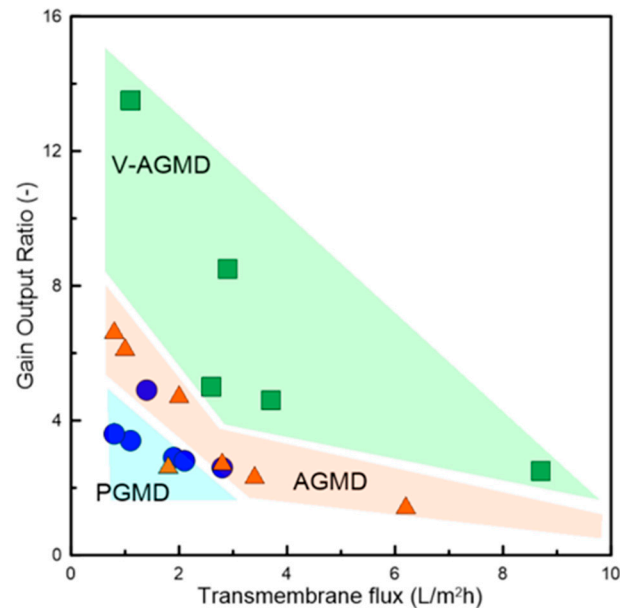

Figure 20. Performance illustration of pilot scale MD variants expressed as gain output ratio (GOR) and transmembrane flux [16]. (AGMD: air gap membrane distillation; V-AGMD: vacuum-enhanced AGMD; and PGMD: permeate gap membrane distillation).

On the other hand, it is of interest to mention that the reported permeate flux values were limited to about 10 L/m<sup>2</sup>h, which is still far below the mass fluxes in RO process.

### 2.3.5. Forward Osmosis (FO)

Forward osmosis (FO) relies on the osmotic phenomenon with a semi-permeable membrane. Unlike RO, it does not use applied pressure to achieve separation of water from dissolved solutes like ions, molecules, and larger particles. In fact, the driving force of this process of the solute's separation from water is the osmotic pressure difference between a high concentration (high osmotic pressure) draw solution and a low concentration (low osmotic pressure) feed solution [76]. Therefore, one of the main advantages of FO over RO can be its low energy consumption. In addition to and for regeneration of the draw solution, the process can use low grade thermal energy. However, the theoretical evaluation of the energy consumption and efficiency of the FO process conducted by McGovern et al. [77] showed that RO is much more energy efficient than FO for seawater purification. They recommended using FO in other possible applications. This finding, which highlighted that RO was more energy efficient than FO, was based on a comparative exercise illustrating that the total energy consumed was 3.58 and 3 kWh/m<sup>3</sup> when FO and two-pass RO were used, respectively [77]. However, several studies including [78] have shown that FO when combined with RO outperforms the standalone RO in terms of energy efficiency and recovery rate. Therefore, and despite the numerous advantages of the FO process reported in the literature, there exist several drawbacks hampering its successful implementation and

development. Examples of these limitations concern the lack of appropriate membranes suitable specifically for the FO process as well as lack of suitable draw solution and its efficient regeneration [79].

FO can be employed in a varied range of applications including seawater desalination, wastewater treatment, dewatering and concentration in the food sector, and removal of dissolved metals [76,79]. The main sub-systems of a forward osmosis unit are given in Figure 21.

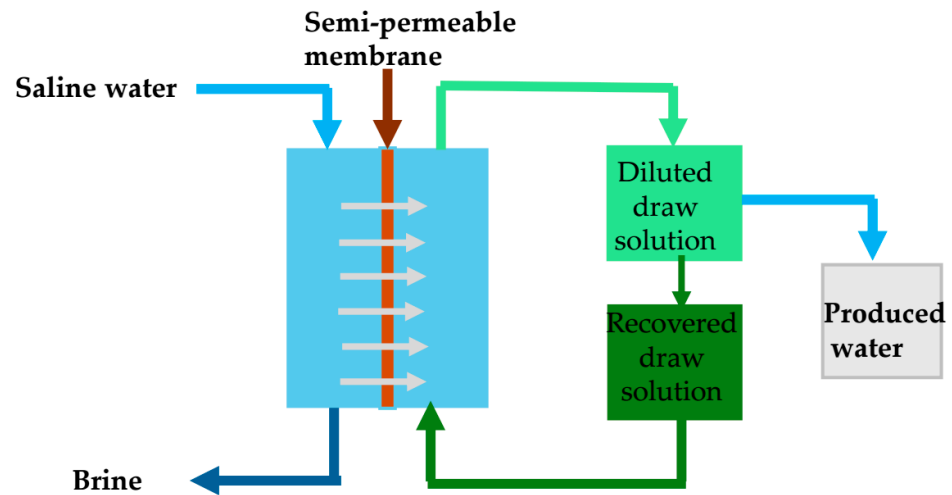

**Figure 21.** Principle and main sub-systems of an FO unit.

However, FO faces several challenges. McGovern et al. [77] highlighted that the final product of the FO is a dilute draw solution and not fresh water like in most other water desalination technologies. This fact is well illustrated in Figure 22. Therefore, FO would need to be integrated with another desalination process to produce fresh water. For instance, FO and RO have been combined in various studies. Furthermore, various types of improvements of the FO process are needed, such as in increasing its very low permeate fluxes, enhancing its membranes properties, and developing suitable draw solutions.

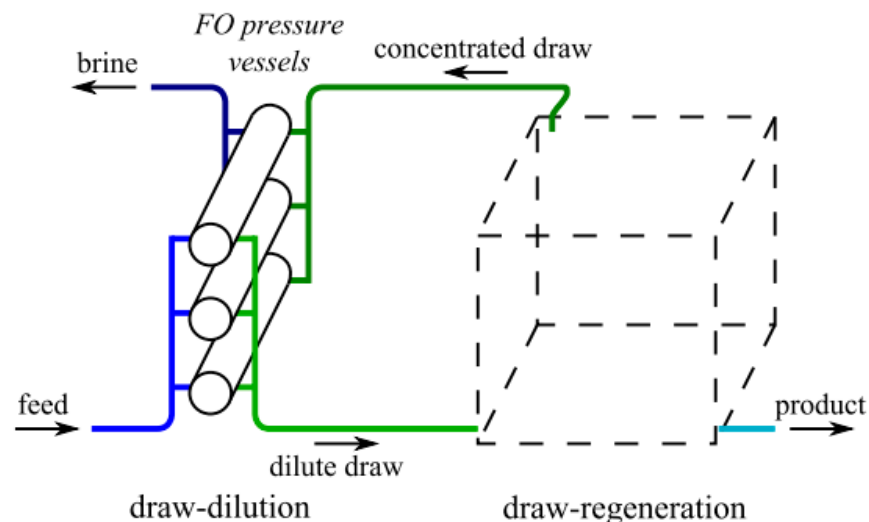

**Figure 22.** A schematic of the FO principle and the need to include a step of draw regeneration in the process [77].

Lee et al. [79] have conducted a comprehensive review of fouling in the two emerging desalination processes of FO and MD. FO is osmotically driven while MD is a thermally driven process. Both processes are some of the most studied technologies due to the

intrinsic advantages of FO compared to RO and the cost-effective potential of MD as a thermally driven process, mainly when driven by waste heat or thermal RE sources. Figure 23 compares the working principles of FO and MD.

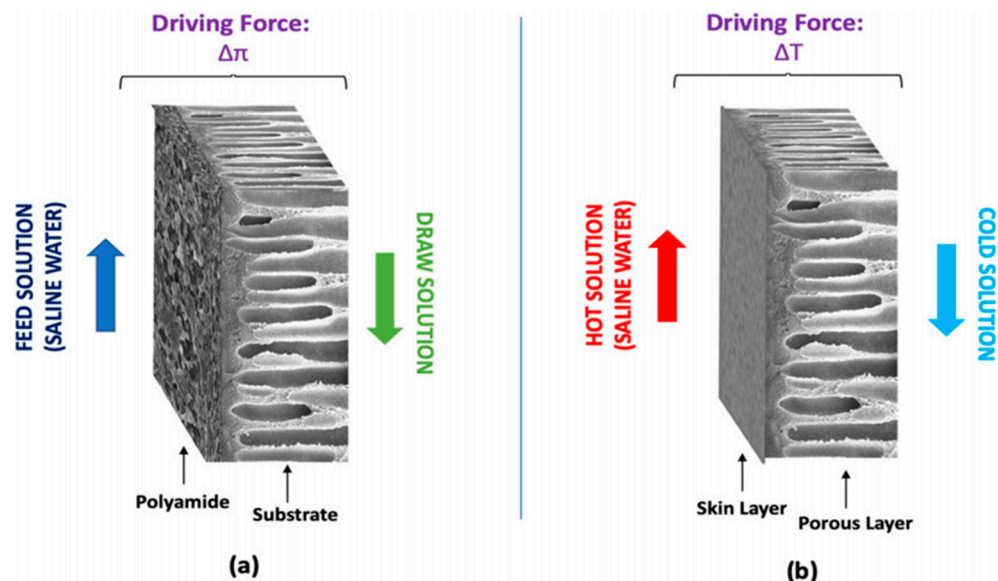

**Figure 23.** Schematic diagram of (a) the FO membrane process and (b) the MD process for desalination [79].

#### 2.4. Hybrid Desalination

Despite the various advantages of the thermal desalination processes, they are known for their high energy consumption and low water recovery [25]. Additionally, and more recently, several seawater reverse osmosis (SWRO) plants have been installed in the Arabian Gulf, but they are facing several operational challenges due to the low performance of the pre-treatment process, especially during red tide events where some SWRO plants have been forced to shut down for several weeks [80]. Moreover, the major non-conventional processes including MD and FO show several limitations. Attempts to enhance the performance of desalination processes such as developing new types of RO membranes, efficient utilization of the supplied energy, and appropriate management of the discharged brine should not stop and should be encouraged. Other paths of process improvement such as hybridization of two or more desalination processes have drawn the attention among the research and industrial desalination communities [81]. Compared to standalone desalination plants, hybrid plants can have more flexibility in operation, larger capacities, better energy management and utilization, smaller intake and outfall structures, and better water and power matching in cogeneration modes [25,82].

Various hybrid configurations have been generated and their performance assessed. The main conclusions of such hybridization studies can be summarized as follows:

- Hybridization, by focusing on the strengths and reducing the limitations of the considered technologies, has led, in general, to improved overall performance of the integrated structures.
- Hybridizing two different types of processes seems to lead to promising findings. Integration of MED-MD, RO-MD and MED-RO are just a few examples of successful hybrid systems [82].
- Membrane distillation and forward osmosis have been considered in numerous investigations of hybrid desalination systems. For instance, MD can treat the concentrate brine leaving MSF, MED, or RO plants.

- The cost and sustainability aspects are not included in all studies. The majority focus on the technical key performance indicators. Therefore, comprehensive studies on hybrid desalination combining techno-economic and environmental aspects need to be conducted.

Gonzalez-Bravo et al. [83] proposed an optimization approach to investigate integrated desalination systems driven by waste heat sources. The results of case studies on hybrid systems highlight the capabilities of the membrane distillation process to be integrated with other processes and that MED-MD shows the best economic and environmental benefits. Figure 24 depicts the total annual profit for 5 MD-based configurations [83].

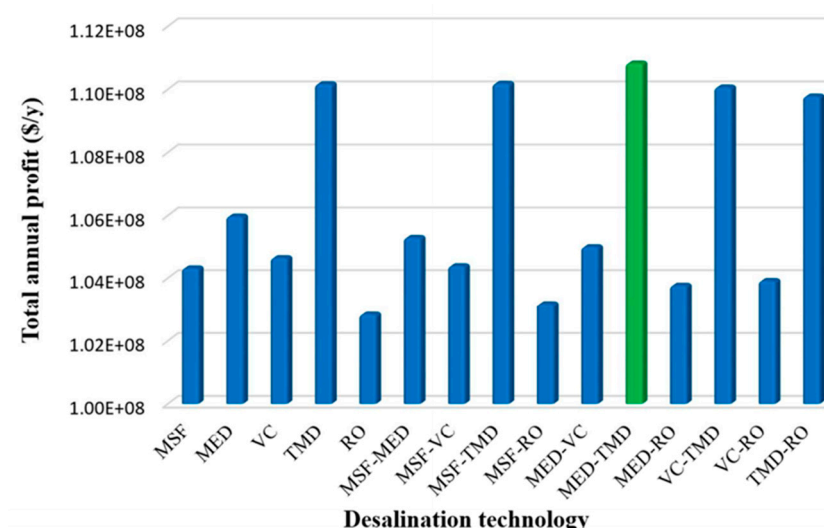

**Figure 24.** Annual profit for several desalination processes in individual or MD hybrid configurations (TMD refers to MD) [83].

The hybridization of thermally driven desalination techniques such as MED and adsorption desalination (AD) can lead to higher performance and a jump in production rate for the same energy inputs. Adsorption desalination uses adsorbent materials to attract and retain dissolved ions from water, producing fresh water. The AD process is based on two main processes: adsorption-assisted evaporation and desorption-activated condensation. Details on AD can be found in [84,85].

Combining MED with AD allows operating within a larger temperature range covering lower levels which avoids scales formation on tube surfaces and accommodates increasing the system effects [86]. Figure 25 illustrates the benefits of coupling MED and AD units. The performance of the integrated MED-AD (or MEDAD) system has been theoretically and experimentally investigated. Promising results in producing more water and lowering the specific energy consumption have been obtained. Figure 26 shows the increase in the water production when MED is coupled with AD [86].

Similarly, combining thermal desalination with absorption cooling has shown notable benefits to boost the production of fresh water and overall energy efficiency [87,88].

At industrial large scale, there are several hybrid conventional desalination plants integrating thermal and reverse osmosis (RO) processes. The AlFujairah-2 (UAE) and Ras Alkhair-1 (KSA) plants are two examples.

- The AlFujairah-2 plant has a total capacity of 591,000 m<sup>3</sup>/day. It is composed of 100 MIGD MED-TVC and a 30 MIGD SWRO [89].
- The Ras Alkhair-1 plant has a total capacity of about 1.036 million m<sup>3</sup>/day, with the MSF’s capacity being 727,203 m<sup>3</sup>/day and the RO capacity 309,061 m<sup>3</sup>/day. The

hybrid plant is composed of 8 MSF units with 20 MIGD capacity each and 17 RO trains with 4 MIGD each [86,89].

An interesting illustration of the benefits of hybridization was presented by Al Bloushi et al. [82] who considered options to improve the performance of the existing MSF desalination plant of Al Taweelah A2 (UAE). The plant is composed of four distillers with a capacity of 56,750 m<sup>3</sup>/day each. The study considered two possible scenarios: replace the MSF plant with an RO plant or consider a hybrid scheme in which an RO unit is integrated with the MSF while maintaining a unit (MSF/RO) capacity of 56,750 m<sup>3</sup>/day. Simulations revealed that the hybridization option results in a notable reduction of about 72% in energy consumption, 53% in specific water production, and 72% in annual gas emission [82].

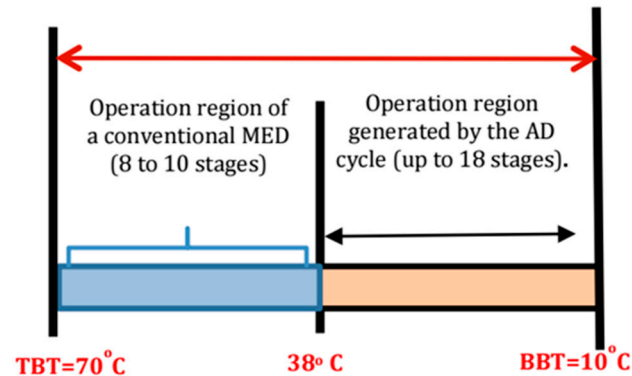

Figure 25. Basic benefit of integrating AD with MED [86].

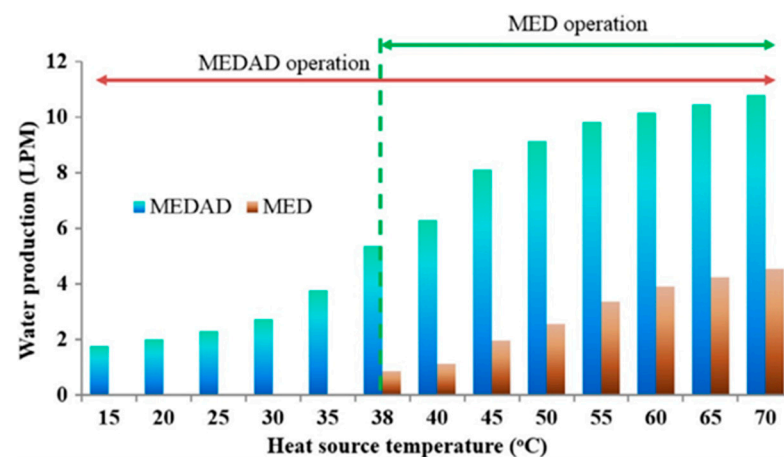

Figure 26. Increase in water production due to the integration of AD and MED units [86].

### 3. Other Important Aspects of Desalination

#### 3.1. Energy, Environment and Desalination

To purify saline water using a desalination process, energy, which can be electrical, thermal, or another energy form, is required. Energy consumption represents a major cost of desalination. Specifically, almost 50% of the operating cost is spent on energy (in thermal and electrical forms). In 2014, desalination was the most energy-intensive water treatment process consuming 75.2 TWh of energy per year [90]. Therefore, energy consumption indicators in desalination appear to be central keys limiting the expansion and growth of this industry.

It is worth clarifying that the evaluation of the energy consumption of a desalination process should be performed using appropriate energy performance metrics that should not be limited to the total amount of energy required for the process, but should include also the type of energy used (for example thermal, electrical or both), the embedded

energy in materials and chemicals, and the degree to which alternative energy sources are utilized [90].

Reducing the energy consumption of a desalination process remains a central target to lower the total cost of produced water. The theoretical minimum energy needed for separating pure water from a saline solution can be considered as one of the energy efficiency metrics of the process. The actual energy consumed in an operating desalination plant can be manyfold the theoretical minimum energy required. Based on data compiled by Antonian [91] corresponding to various medium-sized MSF and MED desalination plants, the average equivalent electric energy consumption is 17.1 kWh/m<sup>3</sup> and 11.9 kWh/m<sup>3</sup> for MSF and MED, respectively. For Saudi MSF desalination plants, the specific energy consumption rates are on average around 16.3 kWh/m<sup>3</sup> [2]. It is worth mentioning that Ihm et al. [89] obtained low values ranging between 6.1 and 6.9 kWh/m<sup>3</sup> for power and desalination cogeneration plants based on combined power cycle and MED-TVC systems. For seawater RO plants, the specific energy consumptions are much lower, approaching 3 kWh/m<sup>3</sup>. SWCC's Shuaiba RO-4 commercial plant achieved a very low specific energy consumption rate of 2.7 kWh/m<sup>3</sup> [2].

One of the critical drawbacks of the desalination industry is its reliance on fossil fuels. Therefore, conventional desalination technologies still have two major environmental concerns:

- A large amount of concentrated brine is damped back to the natural body at daily rates of about 50–70% of the total capacity of a typical SWRO and much more for MSF and MED. Effluents are at a higher temperature than the seawater temperature for thermal desalination processes (the excess can reach 15 °C). They can contain heavy metals and chemical residues such as anti-scalants, chlorine, and anti-foaming or anti-corrosion agents (Shahzad et al. [84]). All these discharges can have drastic impacts on marine life.
- Air pollution resulting from the emission of various gases from fossil fuel combustion systems is the second major environmental impact of desalination. Air pollutants including CO<sub>2</sub> emissions, NO<sub>x</sub>, and SO<sub>2</sub> are released into the atmosphere at different rates depending especially on the desalination type.

Lienhard et al. [86] reported that direct greenhouse gas emissions are about 2.1 to 3.6 kg of CO<sub>2</sub> for each m<sup>3</sup> of fresh water produced using the RO process depending on the type of fuel and conversion technology used to generate the required electricity. Much higher values reaching 8 to 20 kg of CO<sub>2</sub> can be found for thermal desalination processes.

Renewable energy (RE) sources can be integrated with desalination processes in different ways depending on various criteria that include the type of energy needed by the desalination process, the maturity of the technology, the plant water production capacity, etc. Figure 27 depicts a clear picture of the RE and desalination technologies and the worldwide share of each renewable energy source integrated with desalination. It is noted that RO coupled with wind or PV comes first with more than 50% of the market share (Ahmadi et al. [92]). This is because electric-based RE sources, i.e., solar PV and wind, have gained interest as relatively low-cost and reliable technologies to be coupled with desalination techniques. It is worth mentioning that thermal desalination driven by solar energy has low importance in the global market which is attributed to the difficulty of scaling down some mature distillation technologies. The modular RO character is a major parameter in the successful development and deployment of integrated RE-RO systems. Further details on RE desalination systems can be found in [2,5].

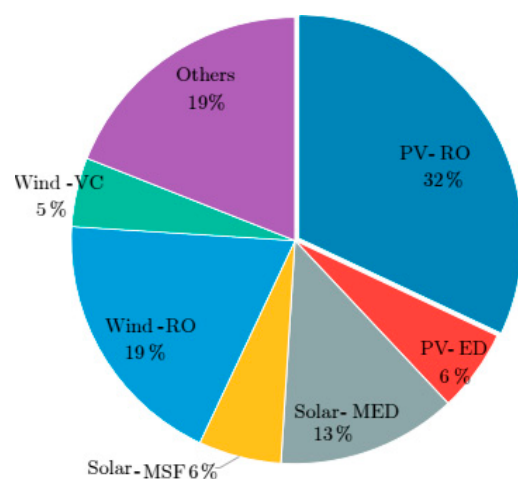

**Figure 27.** Overview of the renewable energy-desalination integrated processes worldwide (Ahmadi et al. [92]).

### 3.2. Performance Indicators of a Typical Desalination Plant

The overall process of desalination is composed of a series of operations that can be broadly organized into three main steps: pre-treatment, desalination, and post-treatment. It is important to note that the performance of any desalination plant, including its energy efficiency, is a function of several factors. The main ones are listed below:

- The desalination process type itself.
- Plant capacity.
- Required energy type.
- Feed water type.
- Pre-treatment method.
- Post-treatment method.
- Brine concentration limit.

The commonly used performance indicators in thermal desalination are as follows:

- The recovery ratio.
- The energy efficiency indicators (the performance ratio, PR, the grain output ratio, GOR, and the specific energy consumption, SEC). It can be demonstrated that SEC, PR, and GOR give essentially the same information and are dependent.
- The specific cooling water mass flow rate ( $R_{cw}$ ), defined as the cooling water mass flow to the distillate mass flow rate ratio.

For membrane-based desalination processes, the quality of the product is measured using the salt rejection rate.

## 4. Comparison Between Desalination Processes

In the above section, the main features of the most used and employed desalination processes and emerging ones have been presented and explained. The benefits of combining two types of desalination processes were also highlighted.

Comparing desalination processes is not a straightforward task. It requires, first, to establish a clear frame in which:

- Enough reliable data and information on the various technologies should be available.
- Realistic and independent indicators should be clearly defined. They should be easy to apply so accurate and reliable results can be drawn.
- A systematic and rigorous methodology of comparison should be established. To avoid qualitative comparison, a scoring method such as a scoring matrix with weights

could be defined. In addition, when using a specific criterion, the comparison must be handled from the same angle. The type of energy used needs to be included in the comparison as explained by Lienhard [93] in his paper entitled “Energy efficiency, primary energy, and apples vs. oranges.”

Therefore, we have established a step-by-step approach that could help in comparing desalination processes and selecting the best ones. This approach can be broadly described as follows:

- Step 1: we can start with a first level comparison based on basic principles and broad information on each desalination process. Table 4 can illustrate this first step.
- Step 2: As given in Table 5, the main advantages and disadvantages of each process are given and discussed. It is clear that comparisons highlighted in Tables 4 and 5 are based on broad information and in some cases on qualitative information.
- Step 3: As shown in Table 6, more quantitative details based on data and numerical values can be used.
- Step 4: A general approach that merges qualitative and quantitative details is used. Appropriate indicators (metrics) are first selected and then implemented with the support of scoring and weighting techniques.

In the next pages, some attempts to compare various conventional and new desalination technologies are presented based on data and information gathered from various sources from the literature reflecting the state of the art of the knowledge and innovation in this fast-growing sector of water desalination.

Table 4 presents the basic principles of the main desalination technologies as well as their main specific maturity and technological development status. These technologies are divided into three categories:

- Mature, which includes conventional processes, namely MSF, MED, VC, RO, and ED.
- Promising processes or those under development including MD, FO, and AD. AD is classified as promising due it is potential to be integrated with thermal desalination by lowering the bottom brine temperature of the process and hence increasing the water production yield.
- Minor, such as CDI and processes that have stagnated development including HDH and FD.

Table 5 exposes the features of the main desalination processes highlighting their corresponding advantages and drawbacks. It is obvious that each technology has its strengths and weaknesses, making the comparison between the processes not easy. Table 6 provides further details with more quantitative information on the main conventional desalination processes. The major highlighted criteria are the reliability of the process, potential of scaling and fouling, operating temperature and pressure ranges, product quality, water recovery, energy consumption, and total water cost.

A high performance of a specific configuration should have the highest scores based on various criteria/metrics. Skuse et al. [50] selected the following criteria:

- Low SEC;
- Low water cost;
- Ease of integration with RE;
- Ease of pre-treatment;
- High water recovery.

These criteria can be interpreted respectively as the following:

- An energy efficiency indicator;
- An economic viability indicator;
- A flexibility indicator;



- An autonomy indicator;
- A conversion/separation efficiency indicator.

Skuse et al. [50] have proposed a qualitative comparison of various membrane-based desalination processes, namely RO, FO, MD, CDI, and their hybrids. The comparison is based on a scale between 0 and 1 (preferred) with equal importance for all criteria. Some general conclusions can be highlighted based on Figure 28:

**Table 4.** Basic principles of main desalination processes.

Technology	Principle	Status
Multi-stage flash (MSF)	Involves boiling seawater by flashing in a series of chambers under progressively lower pressures.	Aging
Multiple effect distillation (MED)	A cascading process where seawater is progressively evaporated and condensed in effects at decreasing pressure and temperature, producing freshwater while efficiently utilizing energy.	Mature
Reverse osmosis (RO)	Removes salt impurities from saline water by forcing it using high pressure through a semi-permeable membrane.	Mature
Vapor compression (MVC or TVC)	Consists of heating the vapor by compressing it using a mechanical vapor compressor (MVC) or a thermal vapor compressor (TVC).	Mature New interests in R & D
Electrodialysis (ED)	Uses ion-selective membranes and an electric field to remove ion salts from water.	Mature
Membrane distillation (MD)	Utilizes a hydrophobic membrane to separate freshwater from saline solution through vapor transport in the membrane and condensing it outside the membrane.	Promising, still in development. Commercial in the food industry.
Forward Osmosis (FO)	Uses a semi-permeable membrane and a concentrated solution to draw freshwater through osmosis.	Still in development, Some applications.
Adsorption desalination (AD)	Utilizes adsorbent materials to attract and retain dissolved ions from water resulting in fresh water.	In development.
Humidification-dehumidification (HDH)	Operates by heating saline water using low-grade thermal energy, evaporating the heated water in a humidifier, and condensing the formed vapor in a dehumidifier.	In development. Limited use and applications.
Freezing desalination (FD)	Saltwater is frozen, and the ice is separated from the concentrated brine, leaving behind freshwater.	Stagnant development.
Capacitive deionization (CDI)	Consists of removing dissolved, charged ionic species from aqueous solutions at atmospheric pressure using direct current electric power.	New, Promising.
Ion Exchange (IX):	Employs ion exchange resins to remove dissolved ions from water.	New.

**Table 5.** Main features of most known desalination processes.

Process	Main Advantages	Main Limitations
MSF	<ul style="list-style-type: none"> <li>- High water quality.</li> <li>- MSF-OT has a flexible structure, potential coupling with sustainable energy sources (solar, geothermal, and waste heat) or other desalination processes.</li> </ul>	<ul style="list-style-type: none"> <li>- High energy consumption.</li> <li>- High total cost.</li> <li>- MSF-BR (brine recirculation) structure is rigid.</li> </ul>
MED	<ul style="list-style-type: none"> <li>- High water quality.</li> <li>- Energy efficient when coupled with TVC</li> <li>- Potential coupling with other systems (sustainable energy sources).</li> </ul>	<ul style="list-style-type: none"> <li>- Scaling problems.</li> </ul>
MVC	<ul style="list-style-type: none"> <li>- High water quality.</li> <li>- Robust.</li> <li>- Can treat highly concentrated waters.</li> </ul>	<ul style="list-style-type: none"> <li>- SEC still high.</li> <li>- Low unit capacity.</li> </ul>
RO	<ul style="list-style-type: none"> <li>- Flexible in construction and operation thanks to its modular structure.</li> <li>- Low SEC.</li> <li>- Has the potential to be integrated with RE sources</li> <li>- Can be easily hybridized.</li> <li>- Scalable: Can be used for small- and large-scale applications.</li> </ul>	<ul style="list-style-type: none"> <li>- Dependent on the feed quality and pretreatment.</li> <li>- Low water quality (first stage).</li> <li>- Fouling potential which requires membrane replacement and additional prefiltration and chemicals.</li> </ul>
ED	<ul style="list-style-type: none"> <li>- Operates at low pressures.</li> <li>- Low energy consumption</li> <li>- Can be used in junction with renewable energy resources</li> </ul>	<ul style="list-style-type: none"> <li>- High capital cost.</li> <li>- Limited salt rejection rates</li> <li>- Limited to brackish waters</li> </ul>
MD	<ul style="list-style-type: none"> <li>- Low operating pressure and operating temperature.</li> <li>- Can be driven by low-grade heat (solar, geothermal, waste heat).</li> <li>- High impurities rejection rate (100%).</li> <li>- Can treat highly concentrated waters.</li> <li>- Can be easily hybridized.</li> </ul>	<ul style="list-style-type: none"> <li>- Fouling issues.</li> <li>- SEC high (even if required energy is low-grade heat).</li> </ul>
FO	<ul style="list-style-type: none"> <li>- Based intrinsically on a natural process (osmosis)</li> <li>- Can be easily hybridized</li> <li>- Low SEC</li> </ul>	<ul style="list-style-type: none"> <li>- Low water quality</li> <li>- Draw solution recovery</li> </ul>
HDH	<ul style="list-style-type: none"> <li>- Robust</li> <li>- Not sensitive to the feed quality.</li> <li>- Low operating temperature and pressure.</li> <li>- Simple operation.</li> <li>- Simple construction and available materials.</li> </ul>	<ul style="list-style-type: none"> <li>- Requires high air flow rates.</li> <li>- -High SEC.</li> <li>- Upscaling is not simple.</li> </ul>
FD	<ul style="list-style-type: none"> <li>- Theoretically, more energy efficient than distillation processes.</li> <li>- Less corrosion and fouling risk thanks to operating at low temperatures</li> <li>- Using low-cost materials such as plastics.</li> </ul>	<ul style="list-style-type: none"> <li>- High operating and capital costs in the ice separation and washing steps.</li> <li>- Low rejection rates.</li> <li>- Various complex operations related to the freezing process and ice removal.</li> </ul>
CDI	<ul style="list-style-type: none"> <li>- Low voltage and minimal electrical safety requirements.</li> <li>- Low SEC</li> </ul>	<ul style="list-style-type: none"> <li>- Limited to low-salinity feed solutions.</li> <li>- Further studies are needed for long-term performance.</li> </ul>

**Table 6.** Comparison of the main desalination processes based on plant size, reliability, pre-treatment, scaling, fouling, temperature range, pressure, product quality, and water recovery, specific energy consumption and unit water cost.

Criterion/ Technology	Maximum Capacity (MIGD)	Reliability	Pretreatment	Scaling	Fouling	Temperature Range (°C)	Pressure (Bar)	Product Water Quality (ppm)	Recovery Ratio	Specific Energy Consumption, SEC, (kWh/m <sup>3</sup> )	Unit Water Cost (USD/m <sup>3</sup> )
BWRO	---	Depends on feed water and pretreatment	Critical	Low	High	Max 45 [94]	Can reach 27 [95]	200–500 [9]	70–90% [96]	1.5–2.5 [97]	0.26–1.33 [9]
SWRO	8/train [53]	Depends on feed water and pretreatment	Critical	Low	High	Max 45 [94]	can reach 80 [95]	400–500 [9] (<50 with 2 pass)	40–55% [96]	3–9 [97]	0.45–1.72 [9]
MSF	20/unit [86]	Highest	Low	High	Low	90–110 [98] Can reach 117 [99]	Low	<25	10–25% [100]	12.5–28 [90, 97]	0.56–1.75 [9]
MED MED-TVC	- 20/unit [32]	High	Low	High	Low	60–85 [101]	Low 3 [26] Can be 6 or more	<25	23–41% [100]	7.7–21 [97]	0.52–1.5 [9] 0.87–0.95 [9]

- Hybrid structures tend to present better performance than corresponding standalone systems.
- RO-FO and RO-MD show attractiveness based on more than one performance indicator.
- RO and MD standalone systems each show overall good performance.

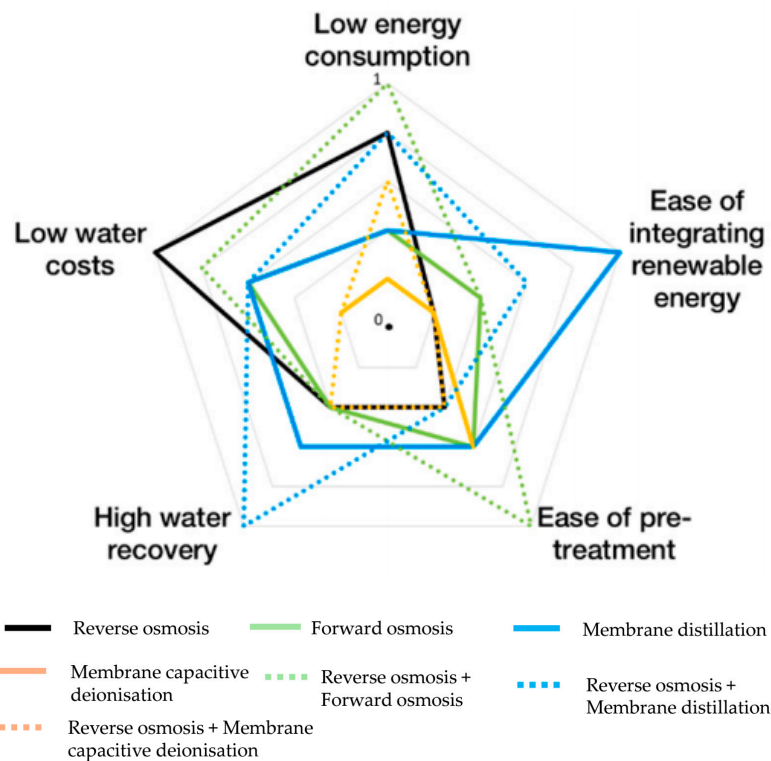

**Figure 28.** Comparison of standalone and hybrid membrane-based systems (Skuse et al. [50]).

As given in Skuse et al. [50], Table 7 explains better how Figure 28 was developed.

**Table 7.** Comparison based on a scale between 0 and 1 (preferred) with equal importance for all criteria of standalone and hybrid membrane-based processes (adapted from [50]).

Indicator	RO	FO	MD	CDI	RO-FO	RO-MD	RO-CDI
Low energy consumption	0.8	0.4	0.4	0.2	1	0.8	0.6
Ease of integration with RE	0.2	0.4	1	0.2	0.4	0.6	0.2
Ease of pretreatment	0.4	0.6	0.6	0.6	1	0.4	0.4
High recovery rate	0.4	0.4	0.6	-	0.4	1	0.4
Low water cost	1	0.6	0.6	0.2	0.8	0.6	0.2

Figure 28 shows that:

- Single RO has a lower cost, and single MD is characterized by its easy integration with renewable energy sources.
- The hybrid RO-FO structure has efficient pre-treatment and low energy consumption.
- Hybrid RO-MD exhibits high water recovery.

It is worth noting that some other performance indicators could be added such as those on the environmental impacts and the plant size. This is just to highlight that these findings from Figure 28 give some kind of guideline rather than concise and final conclusions.

Figure 29 proposes seven metrics that can be used to compare desalination processes based on sustainable requirements. For illustration, Table 8 summarizes the results of a

comparison exercise of six main desalination technologies (four conventional, while MD and FO are still in development) based on the metrics highlighted in Figure 29.

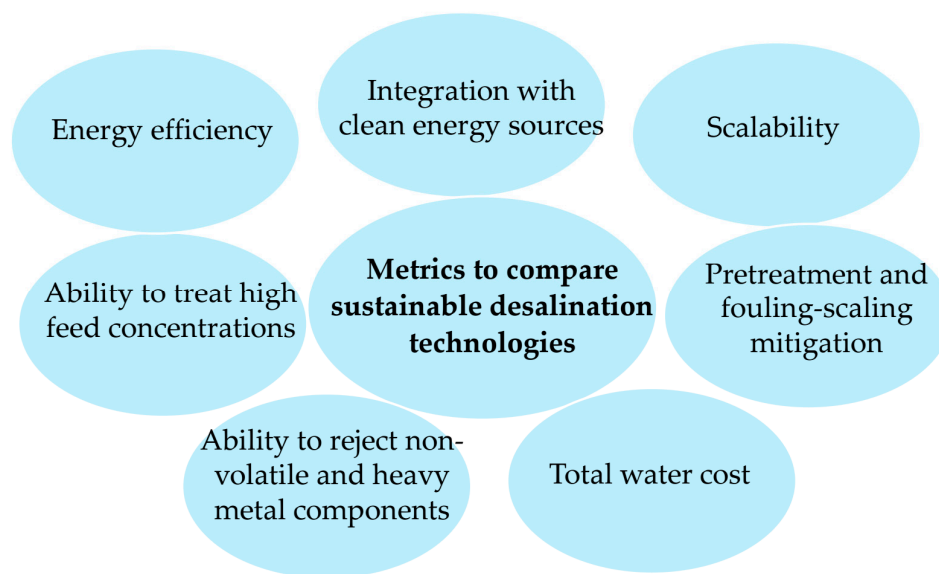

Figure 29. Proposed metrics for comparison of main conventional and emerging desalination processes.

Table 8. Comparison of the main conventional and promising desalination technologies based on various metrics.

Metric Process	Energy Efficiency (#1)	Scalability (#2)	Can Treat High Feed Concentration (#3)	Integration with Clean Energy Sources (#4)	Rejection of Non-Volatile, HM and Others (#5)	Pre-Treatment, Fouling/Scaling Potential (#6)	Total Water Cost (#7)
RO	8	9	2	8	2	3	7
MED	5	5	5	6	6	6	6
MSF	3	2	4	4	6	5	4
MVC	4	3	7	7	6	6	3
MD	3	5	8	8	8	7	2
FO	6	5	6	5	4	3	2

These metrics have been retained after a concise and critical literature survey as mentioned above and considering an important frame which is sustainability. They have been selected as an attempt to develop a unified method allowing the comparison of current and future desalination processes, particularly as related to sustainability. It is worth noting that other criteria could be added to this list, such as reliability and availability. However, we believe that the proposed criteria cover the main metrics characterizing sustainable desalination processes in which technological, economic, social, and environmental factors are well represented. Other aspects such as strategic and political or legal could be added; however, it is believed that their specific weights are marginal and limited. Additionally, human health damage risk due to desalination would appear to have limited impact if the mentioned metrics were applied. The recovery ratio is known to be an important parameter translating the separation/conversion efficiency of the process. This parameter is not considered here since it is believed that it is captured in other criteria such as the ability of the process to treat highly concentrated waters. In addition, some criteria such as energy efficiency and water cost can be measured based on reported values from the literature which make the scoring easier to understand. Other criteria such as the ability of the process to be integrated with clean energy sources seem to be more qualitative and more difficult to evaluate. Some specific observations on each metric are given below:

- Energy efficiency is a central criterion to be considered [95,97,101]. It can be clearly measured using the specific energy consumption (SEC) rate, expressed in kWh/m<sup>3</sup>. Even though a certain confusion persists about the accurate SEC values reflecting a common form of energy consumed for each technology, it is established that about 30% of the total water cost is related to energy. Bouma et al. [102] reported that the energy cost in desalination can account for between 25% and 40% of the total water cost. This may suggest that an energy efficiency metric can have an important weight in comparing and selecting desalination technologies [14,85,90,99,101,102].
- Scalability is also selected as an important metric. The ability to enlarge and up-scale desalination technology is crucial, especially when putting forward its integration with clean energy sources. For instance, despite the technological development and maturity of MSF as a large-capacity production technique, its integration with solar thermal and geothermal collection systems is known to be one of its limitations [98,100,101]. On the other hand, some new techniques are still in the early stage of development. Increasing their unit capacity is one of their main challenges.
- The ability to treat concentrated feed waters and brines appears important in a frame of achieving high recovery ratios and approaching minimum liquid discharge limits [16]. Sabour and Ghorashi [103] conducted a comparative study on major desalination techniques with a focus on their potential for valuable mineral extraction.
- In addition, the ability of the water purification process to be easily coupled with clean energy sources including renewable energy ones is identified as a pivotal criterion for sustainable development [23,104].
- High rejection of salts and particularly the ability to reject heavy metals, non-volatile components, and other components is an important criterion that should be considered for sustainable desalination processes.
- Pre-treatment and the ability to control fouling and scaling potential are related to ensuring a smooth and reliable operation of the desalination plants. For instance, scaling and fouling are major weaknesses in MED and RO technologies, respectively [2,30,94].
- The unit cost of produced water is a criterion that is obviously of particular importance and is, therefore, commonly used in making a choice between the different desalination technologies. This parameter is composed of capital and operating costs. Energy consumption, maintenance, pre-treatment and post-treatment chemicals, and membrane replacement form a major part of the operating cost. One may argue that membrane replacement, for example, depends on fouling problems, and energy cost is essentially decided by the level of energy consumption; therefore, this criterion could be considered as included in other criteria, and there would then be no need to include it in the selected criteria. However, the capital cost of each desalination technology which represents the larger part of the total water cost should still be accounted for as one important parameter by itself.

Adopting a scale to compare the desalination techniques using numbers is a widely used approach. It is proposed in this work to consider the following scale from 1 to 9 where 1 refers to poor and 9 to good. Scores 3 and 5 refer to medium-poor and fair while 7 and 9 to medium-good and good. The scores 2, 4, 6, and 8 are intermediate values.

The results shown in Table 8 can help the selection of suitable technology given some inputs related, for example, to the size, the feed quality, the permeate quality, etc. These findings can be explained using the available knowledge on the process's behavior based on the considered criteria. For illustration, we can remind of and highlight the following:

- As reported in Table 6 and based on [53,90,97], the specific energy consumption for RO, MED, and MSF can range between 3 and 9, 7.7 to 21, and 12.5 to 28 kWh/m<sup>3</sup>, respectively. RO has a low SEC but one that is still far from the minimum thermodynamic

value of about 1 kWh/m<sup>3</sup> for seawater desalination. Therefore, it becomes reasonable to allocate the scores 8, 5, and 3 to RO, MED, and MSF, respectively, for the energy efficiency criterion. It is reported that the FO process requires low energy, essentially representing the energy needed to regenerate the draw solution. Even though the MD process requires low-grade thermal energy, several studies revealed that its SEC is still too high and substantial efforts are needed for better energy recovery and management in general. Values between 40 and 100 kWh/m<sup>3</sup> from low-grade energy sources such as solar and geothermal energy have been reported [16,73].

- RO is modular, thus scalable. MED driven by fossil fuel is mature and widely deployed. However, smaller MED units that could be integrated with RE sources, for example, are not yet employed at a larger scale, which affects the corresponding total water cost. MSF is known to have a rigid structure, in particular for the brine recirculation configuration which has been successfully operating for decades in a cogeneration mode [2,22,89]. Although the MSF once-through (OT) configuration shows more flexibility and ability to be coupled with non-conventional energy sources, MSF technology in general has less flexibility than MED or RO to be downscaled. Therefore, and as shown in Table 8, scores of 9, 5, and 2 are proposed for RO, MED, and MSF, respectively, for the scalability metric.
- RO suffers from being sensitive to highly concentrated waters which affects its energy consumption and drastically reduces the recovery ratio. Not all non-volatile components and heavy metals are removed. This is considered one of the major limitations of RO.
- MVC is known for its ability to treat brines and can be smoothly driven by wind and solar PV systems. Since it is a phase change process (evaporation/condensation), the non-volatile components can be rejected. In general, thermal based desalination processes are known to have higher rejection rates [33,82]. In particular, MD has shown a promising ability to treat highly concentrated waters and have high rejection rates. This is reflected in the scores provided to RO (2), MED (5), MSF (4), MVC (7), and MD (8).
- The ability to be coupled with clean energy sources is also a central criterion from a sustainable development perspective. Given the modular characteristics of RO, RO modules can be smoothly coupled with solar PV panels. Successful deployment of PV-RO has been observed for the last two decades. In addition, MVC, which requires electricity to operate, can be driven by solar PV and wind energy. Conventional thermal desalination, essentially MSF, has experienced less success. More efforts are needed to develop optimized, reliable, and low-cost renewable thermal desalination plants. The MD process, however, shows promising potential that should be confirmed through larger scale solar or geothermal MD units [16,86,105]. These comments are intended to justify the proposed scores of 8, 6, 4, 7, and 8 for the RO, MED, MSF, MVC, and MD processes, respectively. These findings emphasize the need to advance the energy supply and desalination technologies and better master their operation and related problems.

Water cost depends on several factors including the desalination process itself, the plant size, and feed water salinity. Based on available data [2,97], RO has the lowest water cost; MSF suffers from its high capital cost. The water cost corresponding to minor techniques, namely MVC, MD, and FO, is inherently linked to the unit capacity which is still low. This makes the RE desalination less cost-effective as compared to fossil fuel-powered desalination [13,106,107].

On the other hand, and in order to have a clear and concise picture of the outcomes of this comparative exercise on desalination technologies, weights corresponding to the

proposed metrics can be provided based on available data and information from the literature. These weights can vary depending on the specific case considered. For example, in locations where energy cost is high, more weight should be assigned to energy efficiency. Similarly, in locations where renewable resources such as solar and wind are limited, integration with clean energy sources will have lower weight. Strategic and planning aspects are also important and differ from one country to another.

We give here an example that could be more related to the specific case of Saudi Arabia and some neighboring countries in which energy efficiency and total cost are the most important criteria. The respective weight for each criterion is proposed as 25% (#1), 15% (#2), 10% (#3), 15% (#4), 5% (#5), 10% (#6), and 20% (#7). This scheme results in the following scores: 6.55, 5.50, 3.65, 4.70, 5.20, and 4.50 for RO, MED, MSF, MVC, MD, and FO, respectively. Based on this illustration, the superiority of RO is confirmed. The MED and MD processes show their importance as potential competition to RO while MSF comes last due to the several drawbacks mentioned above in the frame of sustainable desalination technologies. It should be noted that the above weights can be changed, and different findings will be obtained.

## 5. Conclusions

This work presents a comprehensive overview of the conventional and emerging desalination processes and highlights their respective advantages and drawbacks using updated data and information from various sources, including from industry. The capabilities and limitations of each process have been discussed and their potential for growth and further development were highlighted. RO-based desalination techniques are spreading not only worldwide but also in the Gulf countries, especially in Saudi Arabia. However, thermal processes can still have space for use in hybridization and cogeneration configurations. Membrane distillation and mechanical vapor compression have attracted recent interest for desalination of concentrated brines.

Several comparisons between the main desalination processes have been presented using specific indicators to underline the superiority of one process over the others. However, any comparison is not a straightforward task due to the numerous factors and variables involved in the desalination process and the difficulty of clearly defining the most important key performance indicators. Reducing energy consumption and the total cost of desalination are strategic aims. Measures of developing sustainable energy–desalination integration are needed.

Important metrics to compare the performance and capability of desalination technologies have been proposed in the frame of sustainability in which environmental, technical, economic, and social factors are considered. An illustrative example based on specific criteria weights shows that the RO process remains the most important sustainable desalination technology while MSF faces real limitations.

**Author Contributions:** Conceptualization, J.O., R.S. and M.A.; methodology, J.O. and R.S.; formal analysis, J.O.; investigation, J.O.; writing—original draft preparation, J.O.; writing—review and editing, J.O., R.S. and M.A. All authors have read and agreed to the published version of the manuscript.

**Funding:** Fellowship to the first author (J.O.) from King Abdullah City for Atomic and Renewable Energy (K.A.CARE) for 2023–2024.

**Data Availability Statement:** The original contributions presented in this study are included in the article. Further inquiries can be directed to the corresponding author.

**Acknowledgments:** The authors would like to express their profound gratitude to King Abdullah City for Atomic and Renewable Energy (K.A.CARE) for their financial support in accomplishing this work.



**Conflicts of Interest:** The authors declare no conflict of interest.

## References

1. Available online: [www.desaldata.com](http://www.desaldata.com) (accessed on 20 November 2022).
2. “Desalination energy consumption”, A Comprehensive Report on Energy Consumption in the Water Desalination Sector, Saudi Water Authority. Available online: <https://swa-cdn.swa.gov.sa/Reports/%D8%A7%D8%B3%D8%AA%D9%87%D9%84%D8%A7%D9%83%20%D8%A7%D9%84%D8%B7%D8%A7%D9%82%D8%A9%20%D9%81%D9%8A%20%D8%B5%D9%86%D8%A7%D8%B9%D8%A9%20%D8%AA%D8%AD%D9%84%D9%8A%D8%A9%20%D8%A7%D9%84%D9%85%D9%8A%D8%A7%D9%87.pdf> (accessed on 26 December 2024).
3. Ohlund, R.J.; Dahdah, B.H.; Guillen, G.R.; Childress, A.E. Augmenting Ocean water desalination with potable reuse: Concept feasibility in terms of cost and environmental impacts. *Desalination* **2024**, *569*, 116941. [[CrossRef](#)]
4. Belmechdi, F.; Otmani, S.; Taha-Janani, M. Global trends of solar desalination research: A bibliometric analysis during 2010–2021 and focus on Morocco. *Desalination* **2023**, *555*, 116490. [[CrossRef](#)]
5. Hassan, A.A.; Awad, M.M. Bibliometric analysis on hybrid renewable energy-driven desalination technologies. *Energy Nexus* **2023**, *11*, 100215. [[CrossRef](#)]
6. Ashraf, H.M.; Al-Sobhi, A.A.; El-Naas, M.H. Mapping the desalination journal: A systematic bibliometric study over 54 years. *Desalination* **2022**, *526*, 115535. [[CrossRef](#)]
7. Tharayil, J.M.; Chinnaiyan, P.; John, D.M.; Kishore, M.S. Environmental sustainability of FO membrane separation applications—Bibliometric analysis and state-of-the-art review. *Results Eng.* **2024**, *21*, 101677. [[CrossRef](#)]
8. Ma, J.; Zhou, R.; Yu, F. Hotspots and future trends of capacitive deionization technology: A bibliometric review. *Desalination* **2024**, *571*, 117107. [[CrossRef](#)]
9. Curto, D.; Franzitta, V.; Guercio, A. A Review of the Water Desalination Technologies. *Appl. Sci.* **2021**, *11*, 670. [[CrossRef](#)]
10. Kariman, H.; Shafieian, A.; Khiadani, M. Small scale desalination technologies: A comprehensive review. *Desalination* **2023**, *567*, 116985. [[CrossRef](#)]
11. Abejón, R.; Romero, J.; Quijada-Maldonado, E. Potential of membrane distillation for water recovery and reuse in water stress scenarios: Perspective from a bibliometric analysis. *Desalination* **2024**, *591*, 117989. [[CrossRef](#)]
12. Dias Pereira, G.L.; Jegatheesan, V. Mapping the evolution of seawater desalination research (2000–2024): Bibliometric and co-word analysis of 11,000+ publications. *Desalination* **2024**, *591*, 118029. [[CrossRef](#)]
13. Bhagwati, A.; Shah, M.; Prajapati, M. Emerging technologies to sustainability: A comprehensive study on solar desalination for sustainable development. *Sustain. Manuf. Serv. Econ.* **2023**, *2*, 100007. [[CrossRef](#)]
14. Naseer, M.N.; Zaidi, A.A.; Khan, H.; Kumar, S.; Owais, M.T.B.; Wahab, Y.A.; Dutta, K.; Jaafar, J.; Uzair, M.J.; Mohd, R.; et al. Desalination technology for energy-efficient and low-cost water production: A bibliometric analysis. *Green Process. Synth.* **2022**, *11*, 306–315. [[CrossRef](#)]
15. Eke, J.; Yusuf, A.; Giwa, A.; Sodiq, A. The global status of desalination: An assessment of current desalination technologies, plants and capacity. *Desalination* **2020**, *495*, 114633. [[CrossRef](#)]
16. Politano, A.; Al-Juboori, R.A.; Alnajdi, S.; Alsaati, A.; Athanassiou, A.; Bar-Sadan, M.; Beni, A.N.; Campi, D.; Cupolillo, A.; D’Olimpio, G.; et al. 2024 roadmap on membrane desalination technology at the water-energy nexus. *J. Phys. Energy* **2024**, *6*, 021502. [[CrossRef](#)]
17. Ahmed, F.E.; Khalil, A.; Hilal, N. Emerging desalination technologies: Current status, challenges and future trends. *Desalination* **2021**, *517*, 115183. [[CrossRef](#)]
18. Ihsanullah, I.; Atieh, M.A.; Sajid, M.; Nazal, M.K. Desalination and environment: A critical analysis of impacts, mitigation strategies, and greener desalination technologies. *Sci. Total Environ.* **2021**, *780*, 146585. [[CrossRef](#)]
19. Elsaid, K.; Kamil, M.; Sayed, E.T.; Abdelkareem, M.A.; Wilberforce, T.; Olabi, A. Environmental impact of desalination technologies: A review. *Sci. Total Environ.* **2020**, *748*, 141528. [[CrossRef](#)] [[PubMed](#)]
20. Youssef, P.G.; AL-Dadah, R.K.; Mahmoud, S.M. Comparative Analysis of Desalination Technologies. *Energy Procedia* **2014**, *61*, 2604–2607. [[CrossRef](#)]
21. Chebli, H.; Fornarelli, F.; Bellantuono, N. Comparison of Desalination Technologies and Assessment of Their Sustainability. *J. Phys. Conf. Ser.* **2023**, *2648*, 012021. [[CrossRef](#)]
22. Altmann, T.; Bouma, A.T.; Robert, J.; Swaminathan, J.; Lienhard, V.J.H. A Comparison of Desalination Technologies on the Basis of Primary Energy Consumption. In Proceedings of the International Desalination Association World Congress on Desalination and Water Reuse 2019, Dubai, United Arab Emirates, 20–24 October 2019.
23. Thi, D.; Trang, H.; Pasztor, T.; Fozer, D.; Manenti, F.; Toth, A.J. Comparison of Desalination Technologies Using Renewable Energy Sources with Life Cycle, PESTLE, and Multi-Criteria Decision Analyses. *Water* **2021**, *13*, 3023. [[CrossRef](#)]
24. Yan, D. Membrane Desalination Technologies. In *A Multidisciplinary Introduction to Desalination*, 1st ed.; Bazargan, A., Ed.; River Publishers: New York, NY, USA, 2018; Chapter 6, p. 716. [[CrossRef](#)]

25. Ali, E.; Orfi, J.; AlAnsary, H.; Lee, J.G.; Alpatova, A.; Ghaffour, N. Integration of multi effect evaporation and membrane distillation desalination processes for enhanced performance and recovery ratios. *Desalination* **2020**, *493*, 114619. [CrossRef]
26. Elsayed, M.L.; Mesalhy, O.; Mohammed, R.H.; Chow, L.C. Exergy and thermo-economic analysis for MED-TVC desalination systems. *Desalination* **2018**, *447*, 29–42. [CrossRef]
27. Tao, P.; Ni, G.; Song, C.; Shang, W.; Wu, J.; Zhu, J.; Chen, G.; Deng, T. Solar-driven interfacial evaporation. *Nat. Energy* **2018**, *3*, 1031–1041. [CrossRef]
28. Du, C.; Han, D.; Huang, C. Enhanced vapor condensation by thermal redistribution on the evaporation surface in heat-localized solar desalination. *Appl. Therm. Eng.* **2022**, *215*, 118941. [CrossRef]
29. Bazargan, A.; Salgado, B. Fundamentals of Desalination Technology. In *A Multidisciplinary Introduction to Desalination*, 1st ed.; Bazargan, A., Ed.; River Publishers: New York, NY, USA, 2018; Chapter 3, p. 716. [CrossRef]
30. Hamed, O.A. Thermal Desalination: Performance and Challenges. In *Corrosion and Fouling Control in Desalination Industry*; Saji, V.S., Meroufel, A.A., Sorour, A.A., Eds.; Springer: Cham, Switzerland, 2020. [CrossRef]
31. Darwish, M.A.; Abdulrahim, H.K. Feed water arrangements in a multi-effect desalting system. *Desalination* **2008**, *228*, 30–54. [CrossRef]
32. Miyamora, H. (Sasakura Company, Osaka, Japan); Al-Shuaib, M. (Seminar in the Department of Mechanical Engineering, King Saud University, Riyadh, Saudi Arabia). Personal communication, 2018.
33. Fath, H.E.S. Desalination and Greenhouses. In *Unconventional Water Resources and Agriculture in Egypt, Volume 75, The Handbook of Environmental Chemistry*; Barcelo, D., Kostianoy, A.G., Eds.; Springer: Berlin/Heidelberg, Germany, 2018. Available online: <https://www.springer.com/series/698> (accessed on 30 September 2024).
34. Ali, E.; Orfi, J.; AlAnsary, H.; Alsaadi, A.S.; Ghaffour, N. Novel multistage flash reversal Concept: Modelling and analysis. *Appl. Therm. Eng.* **2022**, *217*, 119223. [CrossRef]
35. El-Ghonemy, A.M.K. Performance test of a sea water multi-stage flash distillation plant: Case study. *Alex. Eng. J.* **2018**, *57*, 2401–2413. [CrossRef]
36. Khoshrou, I.; Jafari Nasr, M.R.; Bakhtari, K. New opportunities in mass and energy consumption of the Multi-Stage Flash Distillation type of brackish water desalination process. *Sol. Energy* **2017**, *153*, 115–125. [CrossRef]
37. Yadav, K.; Gudjonsdottir, M.; Axelsson, G.; Ómarsdóttir, M.; Sircar, A.; Shah, M.; Yadav, A. Geothermal-solar integrated Multistage Flash Distillation Cogeneration system: A cleaner and sustainable solution. *Desalination* **2023**, *566*, 116897. [CrossRef]
38. Shelare, S.; Kumar, R.; Gajbhiye, T.; Kanchan, S. Role of Geothermal Energy in Sustainable Water Desalination—A Review on Current Status, Parameters, and Challenges. *Energies* **2023**, *16*, 2901. [CrossRef]
39. Ali, E.; Orfi, J.; AlAnsary, H.; Baakeem, S.; Alsaadi, A.S.; Ghaffour, N. Advanced structures of reversal multi-stage flash desalination. *Desalination* **2024**, *571*, 117095. [CrossRef]
40. Toth, A.J. Modelling and Optimisation of Multi-Stage Flash Distillation and Reverse Osmosis for Desalination of Saline Process Wastewater Sources. *Membranes* **2020**, *10*, 265. [CrossRef]
41. Yang, Y.; Shen, S.; Zhou, S.; Mu, X.; Zhang, K. Research for the adjustable performance of the thermal vapor compressor in the MED-TVC system. *Desalination Water Treat.* **2013**, *53*, 1725–1734. [CrossRef]
42. Shamet, O.; Antar, M. Mechanical vapor compression desalination technology—A review. *Renew. Sustain. Energy Rev.* **2023**, *187*, 113757. [CrossRef]
43. Jorge, R.; Osunsan, O.; Mark, T. Advanced Mechanical Vapor-Compression Desalination System. In *Desalination, Trends and Technologies*; InTech: London, UK, 2011. [CrossRef]
44. Sharaf, M.; Nafey, N.; García-Rodríguez, L. Thermo-economic analysis of solar thermal power cycles assisted MED-VC (multi effect distillation-vapor compression) desalination processes. *Energy* **2011**, *36*, 2753–2764. [CrossRef]
45. Elsayed, M.L.; Mesalhy, O.; Mohammed, R.H.; Chow, L.C. Transient and thermo-economic analysis of MED-MVC desalination system. *Energy* **2019**, *167*, 283–296. [CrossRef]
46. Shemer, H.; Semiat, R. Sustainable RO desalination—Energy demand and environmental impact. *Desalination* **2017**, *424*, 10–16. [CrossRef]
47. Sajna, M.S.; Elmakki, T.; Schipper, K.; Ihm, H.; Yoo, Y.; Park, B.; Park, H.; Shon, H.K.; Han, D.S. Integrated seawater hub: A nexus of sustainable water, energy, and resource generation. *Desalination* **2024**, *571*, 117065. [CrossRef]
48. Inamuddin; Khan, A. (Eds.) Sustainable Materials and Systems for Water Desalination. In *Advances in Science, Technology & Innovation*; Springer: Cham, Switzerland, 2021. [CrossRef]
49. Kim, J.; Park, K.; Yang, D.R.; Hong, S. A comprehensive review of energy consumption of seawater reverse osmosis desalination plants. *Appl. Energy* **2019**, *254*, 113652. [CrossRef]
50. Skuse, C.; Gallego-Schmid, A.; Azapagic, A.; Gorgojo, P. Can emerging membrane-based desalination technologies replace reverse osmosis? *Desalination* **2021**, *500*, 114844. [CrossRef]
51. Plakas, K.; Sioutopoulos, D.; Karabelas, A. Energy Consumption and Minimization. In *A Multidisciplinary Introduction to Desalination*, 1st ed.; Bazargan, A., Ed.; River Publishers: New York, NY, USA, 2018; Chapter 14, p. 716. [CrossRef]

52. Available online: [www.aquatechtrade.com/](http://www.aquatechtrade.com/) (accessed on 3 October 2024).
53. Chu, K.H.; Lim, J.; Kim, S.-J.; Jeong, T.U.; Hwang, M.H. Determination of optimal design factors and operating conditions in a large-scale seawater reverse osmosis desalination plant. *J. Clean. Prod.* **2020**, *244*, 118918. [[CrossRef](#)]
54. Esmaeilion, F. Hybrid renewable energy systems for desalination. *Appl. Water Sci.* **2020**, *10*, 84. [[CrossRef](#)]
55. Alnajdi, S.; Beni, A.N.; Alsaati, A.A.; Luhar, M.; Childress, A.E.; Warsinger, D.M. Practical minimum energy use of seawater reverse osmosis. *Joule* **2024**, *8*, 3088–3105. [[CrossRef](#)]
56. Cohen, Y.; Semiat, R.; Rahardianto, A. A perspective on reverse osmosis water desalination: Quest for sustainability. *AIChE J.* **2017**, *63*, 1771–1784. [[CrossRef](#)]
57. Hosseinipour, E.; Davies, P.A. Direct experimental comparison of batch reverse osmosis (RO) technologies. *Desalination* **2024**, *583*, 117717. [[CrossRef](#)]
58. Park, K.; Davies, P.A. A compact hybrid batch/semi-batch reverse osmosis (HBSRO) system for high-recovery, low-energy desalination. *Desalination* **2021**, *504*, 114976. [[CrossRef](#)]
59. Werber, J.R.; Deshmukh, A.; Elimelech, M. Can batch or semi-batch processes save energy in reverse-osmosis desalination? *Desalination* **2017**, *402*, 109–122. [[CrossRef](#)]
60. Kalogirou, S.A. *Solar Energy Engineering Processes and Systems*, 2nd ed.; Elsevier: Amsterdam, The Netherlands, 2014; p. 815.
61. Zheng, H. *Solar Energy Desalination Technology*; Elsevier: Amsterdam, The Netherlands, 2017; p. 766.
62. Rahman, M.S.; Al-Khusaibi, M. Freezing-Melting Desalination Processes. In *Desalination: From Water to Water*; Jane Kucera, J., Ed.; Wiley: Hoboken, NJ, USA, 2019; Chapter 10. [[CrossRef](#)]
63. Najim, A. A review of advances in freeze desalination and future prospects. *npj Clean. Water* **2022**, *5*, 15. [[CrossRef](#)]
64. Khan, Q.; Maraqa, M.A.; Mohamed, A.O. Chapter 17—Inland desalination: Techniques, brine management, and environmental concerns. In *Pollution Assessment for Sustainable Practices in Applied Sciences and Engineering*; Abdel-Mohsen, O.M., Paleologos, E.K., Howari, F.M., Eds.; Butterworth-Heinemann: Oxford, UK, 2021; pp. 871–918. [[CrossRef](#)]
65. Al Suwaidi, F.; Younes, H.; Sreepal, V.; Nair, R.R.; Aubry, C.; Zou, L. Strategies for tuning hierarchical porosity of 3D rGO to optimize ion electrosorption. *2D Mater.* **2019**, *6*, 045010. [[CrossRef](#)]
66. Ahmed, M.A.; Tewari, S. Capacitive deionization: Processes, materials and state of the technology. *J. Electroanal. Chem.* **2018**, *813*, 178–192. [[CrossRef](#)]
67. Wang, H.; Liu, Y.; Li, Y.; Xu, X.; Liu, X.; Yao, Y.; Lu, T.; Pan, L. Tactics for boosting the desalination stability of capacitive deionization. *Chem. Eng. J.* **2024**, *496*, 153808. [[CrossRef](#)]
68. Wang, J.; Yuan, J.; Gao, H.W.; Yu, F.; Ma, J. Recent advances on capacitive deionization for defluorination: From electrode materials to engineering application. *Chem. Eng. J.* **2024**, *480*, 147986. [[CrossRef](#)]
69. Younes, H.; Lou, D.; Mao, M.; Rahman, M.M.; AlNahyan, M.; Younis, H.; Hong, H.; Datta, M.K. A review on capacitive deionization: Recent advances in Prussian blue analogues and carbon materials based electrodes. *Hybrid. Adv.* **2024**, *6*, 100191. [[CrossRef](#)]
70. Ahualli, S.; Iglesias, G.R.; Delgado, A.V. Chapter 8—Principles and Theoretical Models of CDI: Experimental Approaches. In *Delgado, Interface Science and Technology*; Silvia Ahualli, Á.V., Ed.; Elsevier: Amsterdam, The Netherlands, 2018; Volume 24, pp. 169–192. [[CrossRef](#)]
71. Mustakeem, M.; Soukane, S.; Nawaz, M.S.; Ghaffour, N. *Desalination by Membrane Distillation*; Intechopen: London, UK, 2021. [[CrossRef](#)]
72. Swaminathan, J.; Chung, H.W.; Warsinger, D.M. Energy efficiency of membrane distillation up to high salinity: Evaluating critical system size and optimal membrane thickness. *Appl. Energy* **2018**, *211*, 715–734. [[CrossRef](#)]
73. Najib, A.; Orfi, J.; Ali, E.; Saleh, J. Thermodynamic analysis of a direct contact membrane distillation system with and without heat recovery based on experimental data. *Desalination* **2019**, *466*, 52–67. [[CrossRef](#)]
74. Ahmad, S.; Abbasi BB, K.; Palvasha, B.A. Desalination by Membrane Distillation. In *Sustainable Materials and Systems for Water Desalination, Advances in Science, Technology, and Innovation*; Inamuddin, Khan, A., Eds.; Springer: Cham, Switzerland, 2021; Chapter 7. [[CrossRef](#)]
75. Schwantes, R.; Seger, J.; Bauer, L.; Winter, D.; Hogen, T.; Koschikowski, J.; Geißen, S.U. Characterization and Assessment of a Novel Plate and Frame MD Module for Single Pass Wastewater Concentration–FEED Gap Air Gap Membrane Distillation. *Membranes* **2019**, *9*, 118. [[CrossRef](#)] [[PubMed](#)]
76. Mohammadifakhr, M.; de Grooth, J.; Roesink, H.D.W.; Kemperman, A.J.B. Forward Osmosis: A Critical Review. *Processes* **2020**, *8*, 404. [[CrossRef](#)]
77. McGovern, R.K.; Lienhard, V.J.H. On the Potential of Forward Osmosis to Energetically Outperform Reverse Osmosis Desalination. *J. Membr. Sci.* **2014**, *469*, 245–250. [[CrossRef](#)]
78. Seo, J.; Kim, Y.M.; Chae, S.H.; Lim, S.J.; Park, H.; Kim, J.H. An optimization strategy for a forward osmosis-reverse osmosis hybrid process for wastewater reuse and seawater desalination: A modeling study. *Desalination* **2019**, *463*, 40–49. [[CrossRef](#)]

79. Lee, W.J.; Ng, Z.C.; Hubadillah, S.K.; Goh, P.S.; Lau, W.J.; Othman, M.H.D.; Ismail, A.F.; Hilal, N. Fouling mitigation in forward osmosis and membrane distillation for desalination. *Desalination* **2020**, *480*, 114338. [CrossRef]
80. Jones, E.; Qadir, M.; Van Vliet, M.T.H.; Smakhtin, V.; Kang, S.M. The state of desalination and brine production: A global outlook. *Sci. Total Environ.* **2019**, *657*, 1343–1356. [CrossRef] [PubMed]
81. Ahmed, F.E.; Hashaikeh, R.; Hilal, N. Hybrid technologies: The future of energy efficient desalination—A review. *Desalination* **2020**, *495*, 114659. [CrossRef]
82. Al Bloushi, A.; Giwa, A.; Mezher, T.; Hasan, S.W. Chapter 3—Environmental Impact and Technoeconomic Analysis of Hybrid MSF/RO Desalination: The Case Study of Al Taweelah A2 Plant. In *Sustainable Desalination Handbook*; Gude, V.G., Ed.; Butterworth-Heinemann: Oxford, UK, 2018; pp. 55–97. [CrossRef]
83. González-Bravo, R.; Ponce-Ortega, J.M.; El-Halwagi, M.M. Optimal Design of Water Desalination Systems Involving Waste Heat Recovery. *Ind. Eng. Chem. Res.* **2017**, *56*, 1834–1847. [CrossRef]
84. Shahzad, M.W.; Burhan, M.; Ang, L.; Ng, K.C. Energy-water-environment nexus underpinning future desalination sustainability. *Desalination* **2017**, *413*, 52–64. [CrossRef]
85. Shahzad, M.W.; Ng, K.C.; Burhan, M.; Qian, C.; Ybyraiikul, D.; Kumja, M.; Jamil, M.A.; Jiang, Y.; Imtiaz, N.; Xu, B.B. Performance Evaluation of Desalination Technologies at Common Energy Platform. In *Alternative Energies and Efficiency Evaluation*; IntechOpen: Rijeka, Croatia, 2022; p. 82050. Available online: [www.intechopen.com/chapters/82050](http://www.intechopen.com/chapters/82050) (accessed on 20 August 2024).
86. Lienhard, V.J.H.; Thiel, G.P.; Warsinger, D.M.; Banchik, L.D. *Low Carbon Desalination Status and Research, Development, and Demonstration Needs*; Technical Report; MIT, Workshop A. Jameel Center: Cambridge, MA, USA, 2016.
87. López-Zavala, R.; Velázquez, N.; González-Urbe, L.A.; Quezada-Espinoza, K.M.; Aguilar-Jiménez, J.A.; Islas, S.; Nakasima-López, M.; González, E. Absorption cooling and desalination system with a novel internal energetic and mass integration that increases capacity and efficiency. *Desalination* **2019**, *471*, 114144. [CrossRef]
88. Shahzad, M.K.; Ding, Y.; Zhang, H.; Dong, Y.; Jamil, S.R.; Adnan, M. Performance analysis of a novel combined open absorption heat pump and FlashME seawater desalination system for flue gas heat and water recovery. *Energy Convers. Manag.* **2024**, *301*, 117996. [CrossRef]
89. Ihm, S.; Al-Najdi, O.Y.; Hamed, O.A.; Jun, G.; Chung, H. Energy cost comparison between MSF, MED and SWRO: Case studies for dual purpose plants. *Desalination* **2016**, *397*, 116–125. [CrossRef]
90. Nassrullah, H.; Anis, S.F.; Hashaikeh, R.; Hilal, N. Energy for desalination: A state-of-the-art review. *Desalination* **2020**, *491*, 114569. [CrossRef]
91. Antonyan, M. Energy Footprint of Water Desalination. Master's Thesis, University of Twente, Enschede, The Netherlands, 2019.
92. Ahmadi, E.; McLellan, B.; Mohammadi-Ivatloo, B.; Tezuka, T. The Role of Renewable Energy Resources in Sustainability of Water Desalination as a Potential Fresh-Water Source: An Updated Review. *Sustainability* **2020**, *12*, 5233. [CrossRef]
93. Lienhard, V.J.H. Energy Efficiency, Primary Energy, and Apples vs. Oranges. IDA Global Connections, Winter 2019 Issue. International Desalination Association. 2018, pp. 31–33. Available online: [https://issuu.com/idadesal/docs/ida\\_global\\_connections\\_winter19](https://issuu.com/idadesal/docs/ida_global_connections_winter19) (accessed on 22 August 2024).
94. Chen, C.; Huang, X.; Prakash, P.; Chilekar, S.; Franks, R. Produced water desalination using high temperature membranes. *Desalination* **2021**, *513*, 115144. [CrossRef]
95. Rabiee, H.; Khalilpour, K.R.; Betts, J.M.; Tapper, N. Chapter 13—Energy-Water Nexus: Renewable-Integrated Hybridized Desalination Systems. In *Polygeneration with Polystorage for Chemical and Energy Hubs*; Khalilpour, K.R., Ed.; Academic Press: Cambridge, MA, USA, 2019; pp. 409–458. [CrossRef]
96. Panagopoulos, A.; Haralambous, K.J.; Loizidou, M. Desalination brine disposal methods and treatment technologies—A review. *Sci. Total Environ.* **2019**, *693*, 133545. [CrossRef] [PubMed]
97. Panagopoulos, A. A comparative study on minimum and actual energy consumption for the treatment of desalination brine. *Energy* **2020**, *212*, 118733. [CrossRef]
98. Hanshik, C.; Jeong, H.; Jeong, K.W.; Choi, S.H. Improved productivity of the MSF (multi-stage flashing) desalination plant by increasing the TBT (top brine temperature). *Energy* **2016**, *107*, 683–692. [CrossRef]
99. Gordon, J.M.; Chua, H.T. Thermodynamic perspective for the specific energy consumption of seawater desalination. *Desalination* **2016**, *386*, 13–18. [CrossRef]
100. Palenzuela, P.; Alarcón-Padilla, D.C.; Zaragoza, G. *Concentrating Solar Power and Desalination Plants: Engineering and Economics of Coupling Multi-Effect Distillation and Solar Plants*; Springer: Berlin/Heidelberg, Germany, 2015.
101. Alasfour, F.N. *Introduction to Desalination: Systems, Processes and Environmental Impacts*; Wiley-VCH: Weinheim, Germany, 2020; p. 390.
102. Bouma, A.T.; Swaminathan, J.; Lienhard, V.J.H. Metrics Matter: Accurately Defining Energy Efficiency in Desalination. *ASME J. Heat Transfer.* **2020**, *142*, 122101. [CrossRef]
103. Sabour, S.M.J.S.; Ghorashi, B. A comprehensive review of major water desalination techniques and mineral extraction from saline water. *Sep. Purif. Technol.* **2024**, *349*, 127913. [CrossRef]

104. Alawad, S.M.; Mansour, R.B.; Al-Sulaiman, F.A.; Rehman, S. Renewable energy systems for water desalination applications: A comprehensive review. *Energy Convers. Manag.* **2023**, *286*, 117035. [[CrossRef](#)]
105. Zaragoza, G.; Andrés-Mañas, J.A.; Ruiz-Aguirre, A. Commercial scale membrane distillation for solar desalination. *npj Clean. Water* **2018**, *1*, 20. [[CrossRef](#)]
106. Napoli, C.; Rioux, B. Evaluating the economic viability of solar-powered desalination: Saudi Arabia as a case study. *Int. J. Water Resour. Dev.* **2015**, *32*, 412–427. [[CrossRef](#)]
107. Caldera, U.; Bogdanov, D.; Breyer, C. Chapter 8—Desalination Costs Using Renewable Energy Technologies. In *Renewable Energy Powered Desalination Handbook*; Gude, V.G., Ed.; Butterworth-Heinemann: Oxford, UK, 2018; pp. 287–329. [[CrossRef](#)]

**Disclaimer/Publisher’s Note:** The statements, opinions and data contained in all publications are solely those of the individual author(s) and contributor(s) and not of MDPI and/or the editor(s). MDPI and/or the editor(s) disclaim responsibility for any injury to people or property resulting from any ideas, methods, instructions or products referred to in the content.