

1. Red and Blue Chair

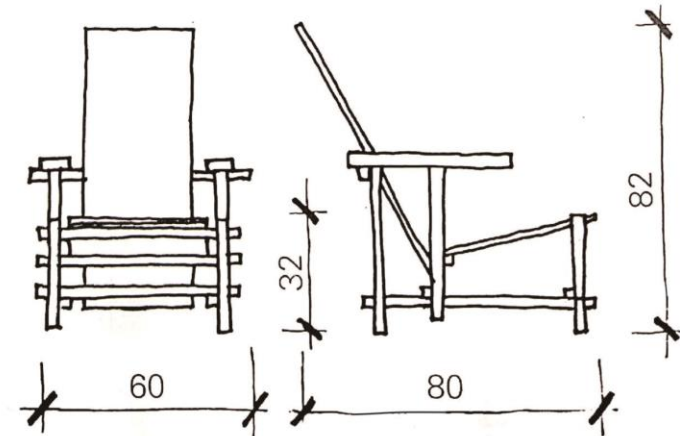

Material:
1. Paint wood

Size: cm



2. Wassily Armchair



Material:

1. Chrome plated tubular metal frame
2. Leather cushion, backrest and armrest

Size: cm

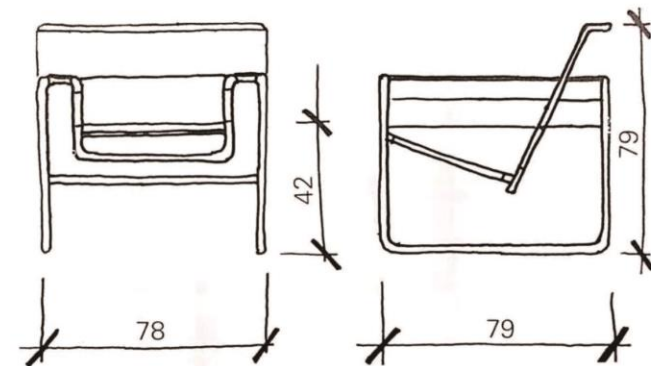

3. Barcelona Chair



Material:

1. Chrome plated iron ring frame
2. Leather cushion
3. Belt

Size: cm

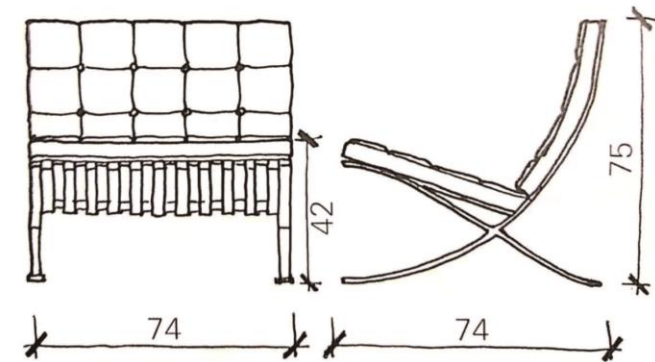

4. Armchair



Material:

1. Fully natural and painted curved laminated wood

Size: cm

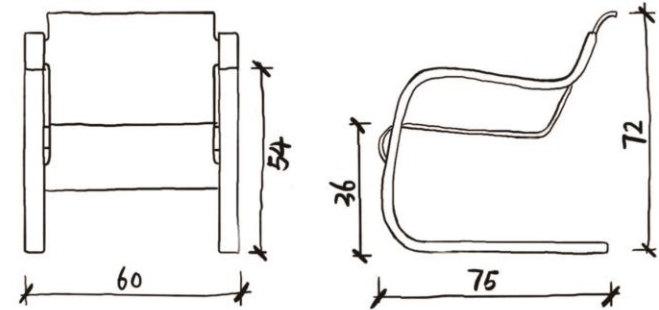

5. Butterfly Chair



Material:

1. Paint metal pipe frame
2. Natural leather or colored canvas covers

Size: cm

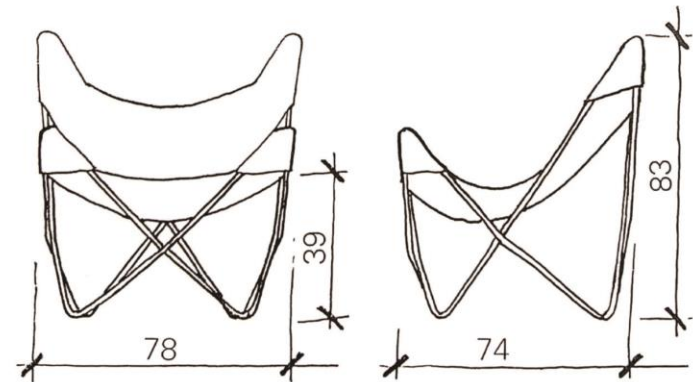

6. PP 501 Chair



Material:

1. Teak solid wood structure
2. Soft mats covered with rattan or leather

Size: cm

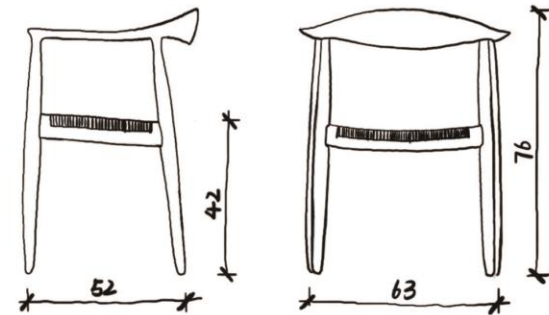

7. Diamond Chair



Material:

1. Pressing and welding metal mesh
2. Chrome plated steel pipe rack
3. Imitation leather cushion

Size: cm

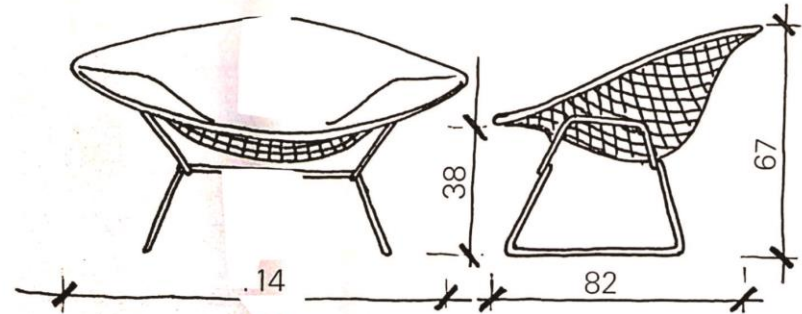

8. Lounge Chair



Material:

1. Natural plywood surgery
2. Cushion and armrest wrapped in black leather
3. Cast aluminum baseboard

Size: cm

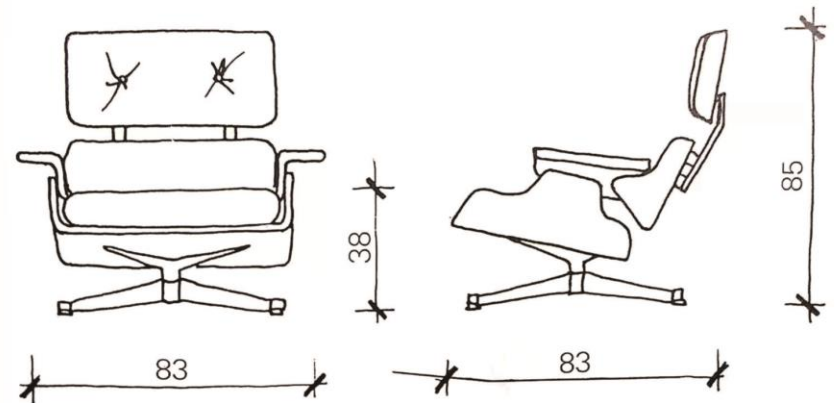

9. Stackable Chair 276S



Material:

1. Colored glass fiber monomer shell

Size: cm

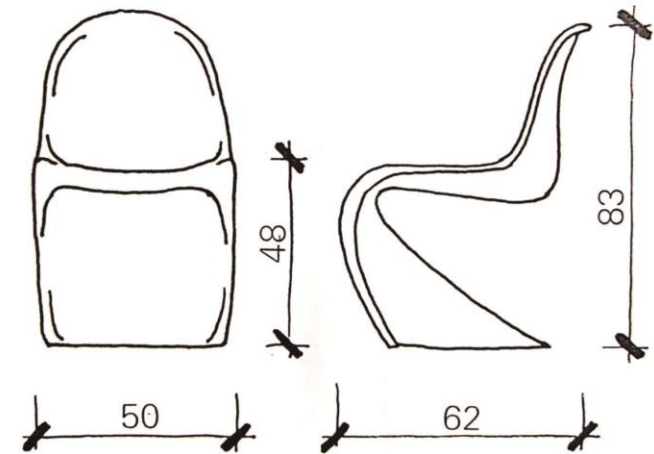

10. Djinn Seats



Material:

1. Metal frame
2. Latex foam covered by fabric

Size: cm

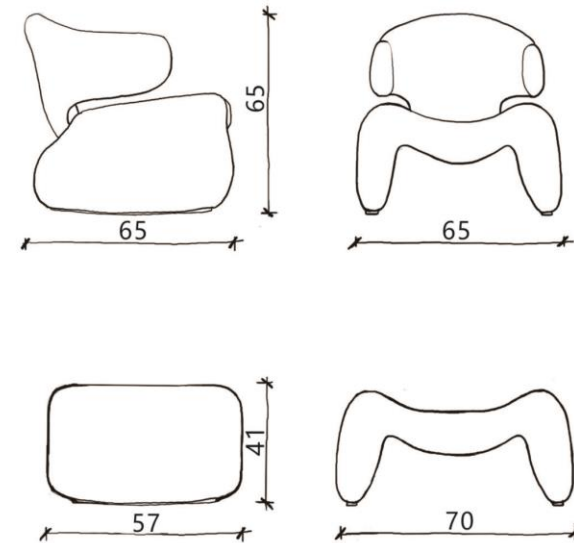

Table S1: Questionnaire

Hello! Thank you very much for your participation in this questionnaire. We assure you that all the information and data in this questionnaire will not be used commercially or leaked. It will only be used for the research of master's students in the School of mechanical engineering of Shandong University.

Your gender: male female

Your age: under 21 21-30 31-40 41-50 over 51

Your major: design-related majors art-related majors others

Your educational background: junior college / bachelor degree master's / doctoral degree others

Scoring Index: Please fill in the corresponding box with the score you approve, with a total of 5 scores ranging from 1 to 5. The score is progressive and 5 is the best. 1 2 3 4 5			1	2	3	4	5	6	7	8	9	10
												
Aesthetic Attribute	Visual Aspect	What do you think of the material of this chair										
		What do you think of the structural shape of this chair										
		What do you think of the overall coordination of this chair										
	Emotional Aspect	Does this chair give you a pleasant psychological feeling										
		What do you think of the style of this chair										
Functional Attribute	Use Aspect	What do you think of the basic function of this chair										
		What do you think of the functional extensibility of this chair										
	Design Aspect	What do you think of the convenience of using this chair										
	Quality Aspect	What do you think of the durability of this chair										
		What do you think of the stability of this chair										
Commercial Attribute	Value Aspect	Will you buy this chair if economic conditions permit										
Human-oriented Attribute	Physiological Aspect	What do you think of the comfort of this chair										
	Psychological Aspect	Does this chair bring you spiritual satisfaction										
	Functional Aspect	Does this chair bring you functional satisfaction										

① Your favorite chair ()

② Your least favorite chair ()