



Article

Identification Process of Selected Graphic Features Apple Tree Pests by Neural Models Type MLP, RBF and DNN

Piotr Boniecki ¹, Maciej Zaborowicz ^{1,*} , Agnieszka Pilarska ²  and Hanna Piekarska-Boniecka ³

¹ Institute of Biosystems Engineering, Poznan University of Life Sciences, 60-637 Poznan, Poland; bonie@up.poznan.pl

² Food Engineering Group, Institute of Plant Origin Food Technology, Poznan University of Life Sciences, 60-637 Poznan, Poland; agnieszka.pilarska@up.poznan.pl

³ Faculty of Horticulture and Landscape Architecture, Poznan University of Life Sciences, 60-637 Poznan, Poland; hanna.boniecka@up.poznan.pl

* Correspondence: maciej.zaborowicz@up.poznan.pl

Received: 28 May 2020; Accepted: 9 June 2020; Published: 10 June 2020



Abstract: In this paper, the classification capabilities of perceptron and radial neural networks are compared using the identification of selected pests feeding in apple tree orchards in Poland as an example. The goal of the study was the neural separation of five selected apple tree orchard pests. The classification was based on graphical information coded as selected characteristic features of the pests, presented in digital images. In the paper, MLP (MultiLayer Perceptrons), RBF (Radial Basis Function) and DNN (Deep Neural Networks) neural classification models are compared, generated using learning files acquired on the basis of information contained in digital photographs of five selected pests. In order to classify the pests, neural modeling methods were used, including digital image analysis techniques. The qualitative analysis of the neural models enabled the selection of optimal neuron topology that was characterized by the highest classification capability. As representative graphic features were selected five selected coefficients of shape and two defined graphical features of the classified objects. The created neuron model is dedicated as a core for computer systems supporting the decision processes occurring during apple production, particularly in the context of apple tree orchard pest protection automation.

Keywords: artificial neural networks; identification of apple pests; deep learning

1. Introduction

The observed progress in the broadly defined applied information technology results in the capability to successfully simulate complex identification processes using increasingly more effective computers. Methods that include computer analysis techniques and modern neural modeling methods are utilized for this purpose. As a result, this enables the identification process to be automated and certain problems arising out of human nature, such as subjectivism of the expert performing the analysis, to be alleviated. In scientific papers, one can often observe problems appearing difficult and non-linear which can relatively easily be solved using broadly defined linear methods and techniques. It is a fact that the popularity of Artificial Neural Networks (ANN) mainly stems from the ability to fairly easily model not only linear but also non-linear problems, and practical studying of matters described using curvilinear models.

Until recently, neural networks working as classifiers represent basic classic ANN topologies: Multilayer Perceptrons (MLP) and Radial Basis Function networks (RBF). Recently, Deep Neural

Networks (DNN) have become increasingly important [1,2]. Despite the significant differences between them, both in terms of their generation and operation, they constitute neural networks defined as complementary classification models.

It is considered that MLP networks were first suggested by [2–4]. In reality, they had been used by numerous researchers already much earlier (the name "perceptron" was introduced by Frank Rosenblatt in the 1960s). One-way multilayer networks of the multilayer perceptron type are among the most studied and most commonly used network topologies. Multilayer perceptrons represent the so-called parametric neural model class. For example, they are characterized by the fact that the number of neurons forming their structure is markedly lower than the learning file size.

The manner of information processing by RBF networks is different. ANN with radial basis functions belong—as do MLP—to the parametric neural model class. The topology of radial networks was proposed by Dave Broomhead and David Lowe [5,6], as well as John Moody and Christian Darkin [7]. RBF networks represent a different—when compared to sigmoid networks—method of mapping the input set into the output file [8,9]. This transformation consists of matching the multivariate approximation function to the required values, i.e., "spreading" a multidimensional hypersurface adapting to the required values over the learning file. RBF networks usually require for construction more neurons than one-way networks with the sigmoid activation function.

In 2006, Hinton's team [10] presented a new method of teaching artificial neural network—a method of deep learning. Deep learning is a class of machine learning methods for hierarchical (deep) models with non-linear layers. The idea of deep learning is to pre-train the network (pretraining), and then to train the network in a supervised manner. Deep learning is a machine learning department that develops around algorithms modeling high-level abstractions in the available data using multiple layers of nonlinear transformations. By design, subsequent levels form a hierarchy of features from the least to the most abstract. Deep Neural Networks are the most popular group of deep learning algorithms. The depth of the neural network architecture is defined as the length of the longest path between the input and output neuron. In forward networks, this translates directly into the number of layers. It is important to emphasize that there is no limit on the number of layers that can be called a deep network. It has been assumed that a network with more than two hidden layers is already a deep network, but with the development of increasingly larger networks, this boundary can be shifted. From 2010, a significant increase in interest in deep learning techniques can be seen, and from 2012, a significant reduction in the inaccuracy of learning networks using new methods. According to trade journals, the DNN (Deep Neural Network) error pattern recognition is about 5%, which is at the level of human error. Another important feature of this technology is the ability to react quickly and operate the learned model in real time [11,12].

The aim of the study was to compare the possibilities of using MLP, RBF and DNN artificial neural networks as classification tools, with the process of identifying selected apple tree orchard pests as an example. To this end, a set of adequate neural classification models was created and subsequently verified, indicating the optimum neural classifier [13–19].

2. Materials and Methods

By way of example, classification capabilities of MLP, RBF and DNN networks as neural information systems supporting the process of identifying selected apple tree orchard pests were compared [20,21]. The study presents classification neural models optimized using teaching sets acquired on the basis of information coded as digital images of selected pests. A particular focus was placed on finding a solution to the problem of identifying 5 selected apple tree pests most common in orchards in Poland, presented in graphical form. In order to classify the pests, neural modeling methods were used, including digital image analysis techniques.

Apple trees may be invaded by many species of pests, but only a few of them may occur in production orchards in numbers. The research material that was used to solve the scientific problem

was a group of 5 pests most commonly feeding in apple tree orchards and posing the highest threat to apple trees [6]:

1. Apple blossom weevil—*Anthonomus pomorum* L.
2. Apple sawfly—*Hoplocampa testudinea* Klug
3. Apple ermine moth—*Yponomeuta malinellus* Zeller
4. Codling moth—*Cydia pomonella* L.
5. Apple clearwing—*Synanthedon myopaeformis* (Borkhausen)

Figure 1 presents the pests whose images were subjected to the neural classification process.



Figure 1. Selected 5 pests of apple tree orchards [6].

For the purposes of creating the neural models, the neural network simulator implemented in the STATISTICA v.12 and DNN simulator H₂O suite was used. The most important step of generating ANN is the creation of teaching files which include the selected characteristic features [22–26]. To this end, 7 numerical input variables and a nominal output variable, which arose out of the nature of the scientific, were specified [27–29]. The first group of assumed characteristic input parameters was a file of 7 selected, standard coefficients of shape, constituting selected geometrical features of the objects. Taking into account the fact that these parameters must provide a clear distinction between the identified objects, the 5 following standard shape coefficients were proposed:

- shape coefficient R_s (cohesion), which is a measure of description of shape, independent from linear transformations (scale, rotation or translation)—it has no unit:

$$R_s = \frac{L^2}{4\pi S} \quad (1)$$

where:

L —circumference of the object,

S —surface area of the object.

- coefficient W_8 , which provides the ration of maximum dimension to the circumference of the object. For objects (insects) with varied, irregular shape, it assumes low values:

$$W_8 = \frac{L_{max}}{L} \quad (2)$$

where:

L_{max} —maximum dimension of the object,

L —circumference of the object.

- Feret coefficient R_F , which characterizes the elongation of the object (it assumes low values for elongated objects and is characterized by high variability):

$$R_F = \frac{L_h}{L_v} \quad (3)$$

where:

L_h —maximum dimension of the object (horizontal),

L_v —maximum dimension of the object (vertical).

- regularity coefficient R_E :

$$R_E = \frac{S}{ab} \quad (4)$$

where:

S —surface area of the object,

a —length of the object,

b —width of the object.

- Malinowska coefficient R_M :

$$R_M = \frac{L}{2\sqrt{\pi S}} - 1 \quad (5)$$

where:

L —circumference of the object,

S —surface area of the object.

The second group of assumed characteristic input parameters had 2 object features:

- object surface area S , which is a sum of pixels of the object
- object circumference L , which is a sum of pixels forming the contour of the object

For each of the 5 pests the 7 above-listed shape coefficients were assumed. As the 7 input variables, the following were assumed:

- (1): measureless shape coefficient R_S ,
- (2): coefficient characterising the intermediate features of the object W_8 ,
- (3): Feret coefficient R_F ,
- (4): regularity coefficient R_E ,
- (5): Malinowska coefficient R_M ,
- (6): pest circumference L ,
- (7): surface area of the pest image S .

As the 1 output variable, the following were assumed:

5-state variable with the following nominal values: 1, 2, 3, 4, 5 (Figure 1).

Basing on the obtained digital images of pests, 1000 cases forming the learning file were generated. There were 200 cases of each pest in this group. The measurements were taken manually in the *ImageJ* application. This file was divided randomly in a standard manner, as follows:

- learning file, containing 500 cases,
- validation file, containing 250 cases,
- test file, containing 250 cases.

The structure of the learning file comprised 7 input variables and 1 nominal output value. A fragment of an example learning file is presented in Table 1.

Table 1. Structure of the learning file.

No.	R_S (1)	W_8 (2)	R_F (3)	R_E (4)	R_M (5)	L (6)	S (7)	Pest (1, 2, 3, 4, 5) (Figure 1)
1	17.359	0.79	244.066	1016.879	3.166	46,761	3193	apple moth
2	1.964	0.423	293.177	410.828	0.401	67,473	1290	apple clearwing
3	3.685	0.301	261.12	501.274	0.92	53,524	1574	apple moth
4	1.538	0.709	378.825	469.745	0.24	112,654	1475	apple clearwing
...
1000	1.157	0.606	350.848	377.389	0.076	96,629	1185	apple moth

3. Results and Discussion

Structures of the generated Artificial Neural Networks (RBF, Multilayer perceptrons (MLP and Deep Neural Networks (DNN) are presented in Figure 2.

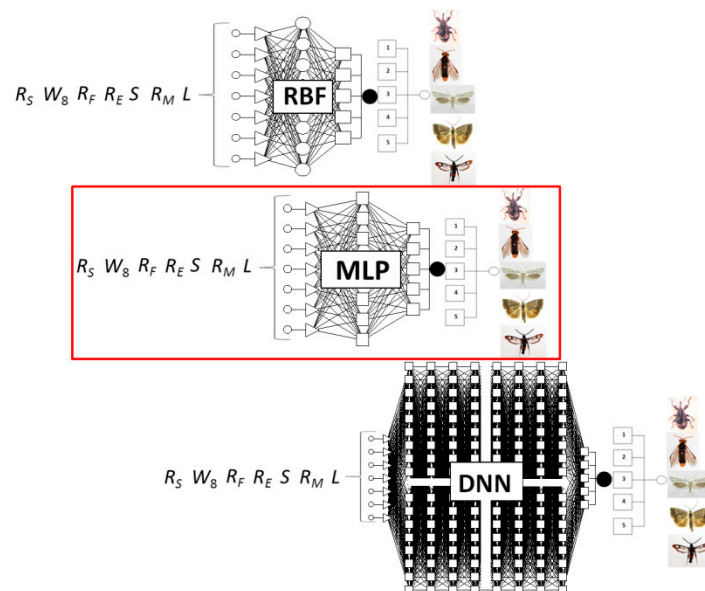

Figure 2. Structures of the generated RBF, MLP and DNN networks.

The standard measure of classification correctness of a generated Artificial Neural Network (ANN) is the RMS (Root Mean Square) error. This measure is defined as the total error made by the network on the (training, test and validation) data file. It is calculated as per formula 6:

$$RMS = \sqrt{\frac{\sum_{i=1}^n (y_i - z_i)^2}{n}} \tag{6}$$

where:

n —number of cases,

y_i —real values,

z_i —values determined using the network.

The RMS error is a numerical value convenient for interpretation, describing the total error that the ANN makes during its operation. For the created MLP models: 7:7-27-5:1, RBF: 7:7-8-5:1 and DNN: hidden matrix: 200 × 200, RMS errors for the: training, validation and test files were adequate. These are presented in Table 2.

Table 2. Root mean square (RMS) errors for the RBF, MLP and DNN.

	RBF	MLP	DNN
Training file	0.165004	0.0001034	0.014921
Validation file	0.183463	0.0001093	0.014921
Test file	0.174319	0.0001063	0.014921

For all neural networks, the low values of the RMS errors for the training, validation and test files, respectively, proves good generalization capabilities of the generated ANN. This means that the generated MLP, RBF and DNN networks did not learn “by heart” and they present good classification capabilities. The MLP network displayed a significantly better classification capability, compared to the DNN and RBF networks, which may mean that the studied identification problem is linear in nature.

The optimum classic neural network was the MLP structure with the 7:7-27-5:1 structure. The input layer comprised seven neurons with a linear postsynaptic function, as well as an activation function. The only hidden layer of the set was composed of 27 sigmoidal neurons, i.e., those with a linear PSP (Post Synaptic Potential) function and a logistic activation function. The network output comprised one sigmoidal neuron representing a five-state nominal variable. The generated neural model was taught by way of the BP (Back Propagation) method in five cycles, 1200 epochs each, and optimized using the CG (Conjugate Gradients) algorithm for 1500 epochs. In the supplementary network training process, the LM (Levenberg-Marquardt) algorithm was employed, adjusting the network for 50 epochs. In the teaching process utilizing the error backward propagation algorithm, the following parameters were assumed:

- decreasing learning coefficient: $\eta = 0.3$ to $\eta = 0.1$,
- momentum coefficient: $\alpha = 0.5$.

The best RBF network was the topology with the 7:7-8-5:1 structure. The input layer comprised seven neurons with a linear PSP function, as well as a linear activation function. The hidden layer of the set was composed of eight radial neurons, i.e., those with a radial PSP function and an exponential activation function. The network output comprised one neuron with a linear PSP function and a linear saturated activation function, representing a five-state nominal variable. The created neural model was taught using optimization algorithms implemented in the STATISTICA v.12 suite. The centers were determined using the k-means method, while deviations were determined by way of the k-neighbors method. The output layer was optimized in a standard manner, using the pseudoinverse technique. The conducted sensitivity analysis showed that all seven variables are important for the operation of all the generated models. For the RBF neural model, these were in order of importance from the most important to the least important: $R_S, S, L, R_E, R_F, W_8, R_M$. For MLP: $R_S, S, L, W_8, R_E, R_F, R_M$.

The DNN model was generated in the first interaction. The model had seven inputs and one output. The hidden neuron matrix had a span of 200×200 . Network sampling was carried out at a speed of 3347 samples per second (Figure 3). The model was generated and optimized after 800 epochs out of 10,000. The entire deep modeling process was carried out in the free H2O application on a computer with an 8th Gen Intel Core i7 processor, type 8565U, 16 GB RAM, HP ProBook 450 G6. The RMS error for the manufactured network was 0.014921. The match ratio was 0.999889. The conducted sensitivity analysis showed that all variables are important for the operation of the model. These were in order of importance from the most important to the least important: $R_E, S, L, R_S, R_F, R_M, W_8$. Dominant descriptors for presented networks are: R_S (shape coefficient), S (surface area), L (circumference) and R_E (regularity coefficient).



Figure 3. Screenshot from H₂O application during model generation.

4. Conclusions

The use of neural modeling and image analysis methods for the purpose of identifying apple tree pests proved to be a correct method that can effectively support decision processes occurring during apple production. Graphical identification of the five selected apple tree pests, performed on the basis of images, was best executed by a multilayer perceptron neural network (MLP). The analysis enabled a conclusion that seven variables containing information on a pest's characteristic colors and the seven suggested shape coefficients are sufficient for correct identification. The study enabled the following conclusions to be formulated:

- The acquired test results demonstrated that ANN are an effective tool supporting the process of identifying chosen pests feeding in apple tree orchards.
- Qualitative analysis of the generated neural models demonstrated that the highest classification capability was reached by a neural topology of the multilayer perceptron type, with the structure: 7:7-27-5:1.
- The MLP network demonstrated a markedly higher classification capability in comparison to the DNN and RBF models. This may mean that the identification problem is linear in nature.
- The study indicates a utilitarian aspect of the created neural model. Potential applications of the generated ANN can be specified as a dedicated information tool that may form the core of an expert system effectively supporting decision processes occurring in the broadly defined apple production process.

Author Contributions: Conceptualization, H.P.-B. and P.B.; methodology, P.B. and M.Z.; software, P.B. and M.Z.; validation, P.B., H.P.-B., A.P. and M.Z.; formal analysis, A.P. and P.B.; investigation, H.P.-B., P.B. and M.Z.; resources, H.P.-B.; data curation, P.B. and M.Z.; writing—original draft preparation, P.B., M.Z. and A.P.; writing—review and editing, H.P.-B. and M.Z.; visualization, P.B. and M.Z.; supervision, P.B.; project administration, P.B. and M.Z.; funding acquisition, P.B. and M.Z. All authors have read and agreed to the published version of the manuscript.

Funding: The study was financed with funds from the National Centre for Research and Development within the framework of the project no. PBS3/B8/26/2015.

Conflicts of Interest: The authors declare no conflict of interest.

References

1. Nowakowski, K.; Raba, B.; Tomczak, R.J.; Boniecki, P.; Kujawa, S.; Nowak, P.J.; Matz, R. Identification of Physical Parameters of Cereal Grain using Computer image Analysis and Neural Models. In Proceedings of the 5th International Conference on Digital Image Processing (ICDIP 2013), Proceedings of SPIE, Beijing, China, 21–22 April 2013; Volume 8878. [[CrossRef](#)]
2. Li, D.; Wang, R.; Xie, C.; Liu, L.; Zhang, J.; Li, R.; Wang, F.; Zhou, M.; Liu, W. A Recognition Method for Rice Plant Diseases and Pests Video Detection Based on Deep Convolutional Neural Network. *Sensors* **2020**, *20*, 578. [[CrossRef](#)] [[PubMed](#)]

3. Boniecki, P.; Nowakowski, K.; Tomczak, R.L. Neural networks type MLP in the process of identification chosen varieties of maize. In Proceedings of the 3rd International Conference on Digital Image Processing (ICDIP 2011), SPIE Proceedings, Chengdu, China, 8 July 2011; Volume 8009, pp. 15–17. [[CrossRef](#)]
4. Pilarska, A.; Pilarski, K.; Witaszek, K.; Waliszewska, H.; Zborowska, M.; Waliszewska, B.; Kolasiński, M.; Szwarc-Rzepka, K. Treatment of dairy waste by anaerobic co-digestion with sewage sludge. *Ecol. Chem. Eng.* **2016**, *23*, 99–115. [[CrossRef](#)]
5. Boniecki, P.; Koszela, K.; Świerczyński, K.; Skwarcz, J.; Zaborowicz, M.; Przybył, J. Neural Visual Detection of Grain Weevil (*Sitophilus granarius* L.). *Agriculture* **2020**, *10*, 25. [[CrossRef](#)]
6. Boniecki, P.; Koszela, K.; Piekarska-Boniecka, H.; Nowakowski, K.; Przybył, J.; Zaborowicz, M.; Raba, B.; Dach, J. Identification of selected apple pests, based on selected graphical parameters. In Proceedings of the 5th International Conference on Digital Image Processing, Proceedings of SPIE, Beijing, China, 19 July 2013; Volume 8878. [[CrossRef](#)]
7. Boniecki, P.; Nowakowski, K.; Ślósarz, P.; Dach, J.; Pilarski, K. Neural image analysis for estimating aerobic and anaerobic decomposition of organic matter based on the example of straw decomposition. In Proceedings of the 4th International Conference on Digital Image Processing, Proceedings of SPIE, Kuala Lumpur, Malaysia, 8 June 2012; Volume 8334. [[CrossRef](#)]
8. Nowakowski, K.; Boniecki, P.; Dach, J. The Identification of Mechanical Damages of Kernels Basis on Neural Image Analysis. In Proceedings of the International Conference on Digital Image Processing (ICDIP 2009), Proceedings Paper, Bangkok, Thailand, 7–9 March 2009; pp. 412–414. [[CrossRef](#)]
9. Kujawa, S.; Tomczak, R.J.; Kluza, T.; Weres, J.; Boniecki, P. A stand for the image acquisition of composted material based on the sewage sludge. In Proceedings of the 4th International Conference on Digital Image Processing, Proceedings of SPIE, Kuala Lumpur, Malaysia, 8 June 2012; Volume 8334. [[CrossRef](#)]
10. Hinton, G.; Osindero, S.; Teh, Y.-W. A Fast Learning Algorithm for Deep Belief Nets. *Neural Comput.* **2006**, *18*, 1527–1554. [[CrossRef](#)] [[PubMed](#)]
11. Sakr, G.E.; Mokbel, M.; Darwich, A.; Khneisser, M.N.; Hadi, A. Comparing Deep Learning And Support Vector Machines for Autonomous Waste Sorting. In Proceedings of the IEEE International Multidisciplinary Conference on Engineering Technologi (IMCET), Beirut, Lebanon, 2–4 November 2016; pp. 207–2012.
12. Zhu, H.; Akrou, M.; Zheng, B.; Pelegris, A.; Jayarajan, A.; Phanishayee, A.; Schroeder, B.; Pekhimenko, G. Benchmarking and Analyzing Deep Neural Network Training. In Proceedings of the IEEE International Symposium on Workload Characterization (IISWC), Raleigh, NC, USA, 30 September–2 October 2018; pp. 88–100. [[CrossRef](#)]
13. Sun, J.; He, X.; Ge, X.; Wu, X.; Shen, J.; Song, Y. Detection of Key Organs in Tomato Based on Deep Migration Learning in a Complex Background. *Agriculture* **2018**, *8*, 196. [[CrossRef](#)]
14. Przybył, K.; Gawałek, J.; Koszela, K.; Przybył, J.; Rudzińska, M.; Gierz, Ł.; Domian, E. Neural Image Analysis and Electron Microscopy to Detect and Describe Selected Quality Factors of Fruit and Vegetable Spray-Dried Powders—Case Study: Chokeberry Powder. *Sensors* **2019**, *19*, 4413. [[CrossRef](#)] [[PubMed](#)]
15. Boniecki, P.; Nowakowski, K.; Tomczak, R.J.; Kujawa, S.; Piekarska-Boniecka, H. The application of the Kohonen neural network in the non-parametric quality-based classification of tomatoes. In Proceedings of the 4th International Conference on Digital Image Processing, Proceedings of SPIE, Kuala Lumpur, Malaysia, 8 June 2012; Volume 8334. [[CrossRef](#)]
16. Zaborowicz, M.; Lisiak, D.; Koszela, K.; Boniecki, P.; Kujawa, S.; Mueller, W.; Gierz, Ł.; Przybył, K.; Ślósarz, P. Application of neural modelling methods in the evaluation of the quality of pork half-carcases. In Proceedings of the 11th International Conference on Digital Image Processing, Proceedings of SPIE, Guangzhou, China, 10–13 May 2019. [[CrossRef](#)]
17. Cerbin, S.; Nowakowski, K.; Dach, J.; Pilarski, K.; Boniecki, P.; Przybył, J.; Lewicki, A. Possibilities of neural image analysis implementation in monitoring of microalgae production as a substrate for biogas plant. In Proceedings of the 4th International Conference on Digital Image Processing (ICDIP 2012), Proceedings of SPIE, Kuala Lumpur, Malaysia, 8 June 2012; Volume 8334. [[CrossRef](#)]
18. Koszela, K.; Otrząsek, J.; Zaborowicz, M.; Boniecki, P.; Mueller, W.; Raba, B.; Lewicki, A.; Przybył, K. Quality assessment of microwave-vacuum dried material with the use of computer image analysis and neural model. In Proceedings of the 6th International Conference on Digital Image Processing, Proceedings of SPIE, Athens, Greece, 16 April 2014; Volume 915913. [[CrossRef](#)]

19. Rice, D.C.J.; Carriveau, R.; Ting, D.S.-K.; Bata, M.H. Evaluation of Crop to Crop Water Demand Forecasting: Tomatoes and Bell Peppers Grown in a Commercial Greenhouse. *Agriculture* **2017**, *7*, 104. [[CrossRef](#)]
20. Nowakowski, K.; Boniecki, P.; Tomczak, R.J. Identification process of corn and barley kernels damages using neural image analysis. In Proceedings of the 3rd International Conference on Digital Image Processing, Proceedings of SPIE, Chengdu, China, 8 July 2011; Volume 8009, pp. 15–17. [[CrossRef](#)]
21. Pilarski, K.; Boniecki, P.; Ślósarz, P.; Dach, J.; Piekarska-Boniecka, H.; Koszela, K. Classification of chosen orchard pests with using the SOFM neural network. *Afr. J. Agric. Res.* **2012**, *7*, 6357–6362.
22. Przybylak, A.; Boniecki, P.; Koszela, K.; Ludwiczak, A.; Zaborowicz, M.; Lisiak, D.; Stanisław, M.; Ślósarz, P. Estimation of intramuscular level of marbling among Whiteheaded Mutton Sheep lambs. *J. Food Eng.* **2016**, *168*, 199–204. [[CrossRef](#)]
23. Boniecki, P.; Piekarska-Boniecka, H.; Świerczyński, K.; Koszela, K.; Zaborowicz, M.; Przybył, J. Detection of the granary weevil based on x-ray images of damaged wheat kernels. *J. Stored Prod. Res.* **2014**, *56*, 38–42. [[CrossRef](#)]
24. Zaborowicz, M.; Fojud, A.; Koszela, K.; Mueller, W.; Gorna, K.; Okon, P.; Piekarska-Boniecka, H. Dedicates computer system AOTK for image processing and analysis of horse navicular bone. In Proceedings of the 9th International Conference on Digital Image Processing (ICDIP), SPIE Proceedings, Hong Kong, China, 21 July 2017; Volume 10420. [[CrossRef](#)]
25. Przybył, K.; Zaborowicz, M.; Koszela, K.; Boniecki, P.; Mueller, W.; Raba, B.; Lewicki, A. Organoleptic damage classification of potatoes with use of image analysis in production process. In Proceedings of the 6th International Conference on Digital Image Processing (ICDIP 2014), SPIE Proceedings, Athens, Greece, 16 April 2014; Volume 9159. [[CrossRef](#)]
26. Boniecki, P.; Dach, J.; Nowakowski, K.; Jakubek, A. Neural image analysis of maturity stage during composting of sewage sludge. In Proceedings of the International Conference on Digital Image Processing, Bangkok, Thailand, 7–9 March 2009; pp. 200–203. [[CrossRef](#)]
27. Zaborowicz, M.; Foujd, A.; Boniecki, P.; Przybył, K.; Gierz, Ł.; Koszela, K.; Ślósarz, P.; Lisiak, D.; Przybył, J. Methodology of Data Processing in the Process of Neural Image Analysis of Pork Half Carcasses. In Proceedings of the 10th International Conference on Digital Image Processing (ICDIP), SPIE Proceedings, Shanghai, China, 9 August 2018; Volume 10806. [[CrossRef](#)]
28. Zaborowicz, M.; Boniecki, P.; Piekarska-Boniecka, H.; Koszela, K.; Mueller, W.; Górna, K.; Okoń, P. Neural classification of the selected family of butterflies. In Proceedings of the 9th International Conference on Digital Image Processing (ICDIP), SPIE Proceedings, Hong Kong, China, 21 July 2017; Volume 10420/1. [[CrossRef](#)]
29. Zaborowicz, M.; Boniecki, P.; Koszela, K.; Przybył, J. Application of neural image analysis in evaluating the quality of greenhouse tomatoes. *Sci. Hort.* **2017**, *218*, 222–229. [[CrossRef](#)]

